

QST

DEVOTED ENTIRELY TO

AMATEUR RADIO

PUBLISHED SINCE 1915 BY THE AMERICAN RADIO RELAY LEAGUE INC.



'Round the world with a radio yacht

SEE PAGE 12

JUNE

1929

25^c

The New Fourth Edition of
**The Radio
Amateur's
Handbook**

By **HANDY** and **HULL**

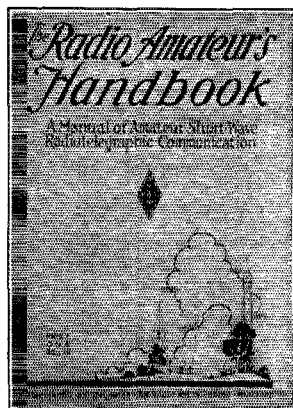

FOR THOSE WHO DON'T KNOW IT:

The Handbook is a practical manual of amateur radio in all its phases, published by the American Radio Relay League, the amateur's own organization. It starts at the beginning and tells the whole story: What amateur radio is, How to be a radio amateur, How to obtain your licenses. How to build the simple apparatus of a simple station. How to build the best known apparatus for the most modern station, How to operate the station. Enough information to keep you busy and interested for five years.

FOR THOSE WHO DO KNOW IT:

For years the Handbook has been the practical working guide of successful amateurs the world over. Now it has been completely revised in terms of 1929, by Mr. Handy, the League's Communication Manager, as to all the aspects of operating procedure, and by Mr. Hull, the director of the League's current Technical Development Program, as to all its features of apparatus and technical matters. Everything in it is on a 1929 basis, replacing the 1928 methods which used to be good enough but aren't any more.

MUCH THAT IS NEW — ALL THAT IS GOOD

Like QST, "Devoted Entirely to Amateur Radio"

Now in its 49th thousand

240 pages, 6½ x 9½, 188 illustrations

In wealth of treatment and profusely of illustration the Handbook is a big book. Printed in usual textbook style it would bulk 500 pages and cost at least \$4, but its publication in the familiar *QST* format makes for handiness and enables its distribution at very modest cost.

ALGERIAN PAPER COVER \$1

STIFF BUCKRAM BINDING \$2

Postpaid anywhere in the World

American Radio Relay League, Hartford, Conn., U. S. A.

RCA RADIOTRON UV-845



*A modulator tube
for improved
amateur phone transmission*

Designed with characteristics especially suited for modulator service, Radiotron UV-845 is capable of effectively modulating a far greater amount of oscillator input power than any other Radiotron widely used by amateurs.

The high modulating ability of the UV-845 with its freedom from distortion will greatly assist the amateur in establishing high quality phone transmission, and will be a source of keen satisfaction to him.

Filament Volts . . .	10
Filament Amperes. . .	3.25
Normal Plate Volts . . .	1000
Normal Grid Bias Volts . . .	-150
Plate Current (m.a.) . . .	75
Plate Resistance (ohms) . . .	2100
Amplification Factor . . .	5
Max. Plate Dissipation (watts)	75
Oscillator Input Watts for each UV-845 (Mod. Factor 0.6)	120
Price,	\$39.00

Radiotron UV-845 may, for certain amateur use, be obtained through the RCA DISTRICT OFFICE nearest you.

RADIOTRON DIVISION

RADIO-VICTOR CORPORATION OF AMERICA

NEW YORK—261 Fifth Ave.

CHICAGO—100 West Monroe St.

SAN FRANCISCO—235 Montgomery St.

DALLAS—Santa Fe Bldg.

ATLANTA—101 Marietta St.

Most Astounding Value Ever Offered!

K O L S T E R

ELECTRO-DYNAMIC REPRODUCER

Combined with 210 Power Amplifier and "B" Supply Unit

THESE Dynamic Reproducers are Kolster built, packed in the original Kolster cases and cartons, shipped direct to us from the Kolster factory from whom we have purchased all of these Dynamic Reproducers. Every Dynamic Reproducer is brand new, each bears the Kolster guarantee tag and the original serial number.

Such opportunity as herein presented is seldom available. And they won't last long at this low price. We suggest quick action — there's quality here — at a price heretofore unknown.

THIS finely matched, rugged unit, comprises a complete heavy duty Electro-Dynamic Reproducer, including a 210 Power Amplifier with "B" supply unit, all self-contained on a steel frame. It weighs 45 pounds without the cabinet. The cabinet itself is of pencil-striped walnut, beautifully designed with Cathedral grille. It is equipped with switch for control of house current to reproducer, power unit and amplifier. A pilot light indicates when the Reproducer is in operation.

If desired, the 210 Power Amplifier will also supply 22, 67 and 90 volts "B" current, sufficient for any set using up to 8 tubes. An automatic voltage regulator tube, UX-874, maintains the "B" voltage silent and steady.

This Electro-Dynamic Reproducer can be used with any battery or A.C. set, replacing the last audio stage or be used with all tubes of the set. Wherever used, it will bring out every shading and range of tone; every note is reproduced with utmost faithfulness, pure and undistorted. It will modernize any radio receiver.

The following tubes are required for its operation: 2-UX-281 (for full-wave rectification); 1-UX-210 (for super power amplification); 1-UX-874 (for voltage regulation). For use with phonograph pick-up, one additional audio stage is recommended between the pick-up and this Reproducer.

A 20-ft. cable is included with each instrument. Operates direct from 50-60 cycle, 110-120 volt A.C. current.

Licensed under patents of RCA and Lektophone Corp.



MODEL K-5

Height 42"
Width 25½"
Depth 19"

Features:

1. Electro-Dynamic Reproducer (10¼-in. dia.).
2. 210 Power Amplifier. Fine tone quality.
3. Supplies "B" voltage, if desired.
4. Can be used with any electric or battery set.
5. Complete A.C. Electric operation.
6. Beautiful pencil-striped walnut cabinet.

LIST PRICE \$175.00 Never \$49.50
(without tubes) Before

Terms: 20% cash with order, balance C.O.D., F.O.B. New York

AMERICAN SALES CO., 19-21 Warren Street, New York City



SPECIALS IN R.C.A. PRODUCTS



P. T. 537 FILAMENT RHEOSTATS

Rated to carry 15 amps.

An absolute necessity for the control of U.V. 203, 203A, 204, 204A and U.V. 851 Transmitting Tubes and 217, 217A, 217C and U.V. 1651 Rectifying Tubes.

LIST
\$10.00



Special **\$3.75 ea.**

ROTARY GRID CHOPPER WHEEL

MODEL P.X. 1638

and Contract Brush Model P.T. 1642

For use with C.W. Vacuum Tube Transmitters. Gives 100 per cent modulation since oscillation can be completely started and stopped at audio frequencies. The note obtained can be varied to any desired pitch by changing the driving motor speed.

Complete with shaft bushing for 5-16" or 1/4" motor shaft. When ordering mention size wanted.



LIST
\$7.45

Special **\$1.25 ea.**

VARIABLE MICA CONDENSER

MODEL U.C. 1819

Capacity .0001 to .005 Mfd.

A Mica Condenser which may be varied continuously from a minimum to a maximum value. Its capacity curve is a straight line, it has a very low electric loss. Used as a grid, antenna, or secondary tuning condenser.

LIST
\$8.75

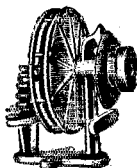

Special **\$1.75 ea.**

PORCELAIN LOW-LOSS SOCKETS

MODEL U.R. 542

For use with U.X. 866, 852, 865, 860, 245, 210 and 250 tubes

On account of its low specific inductive capacity and its high insulating qualities, these Sockets are excellent for Short Wave work and especially adapted to the above tubes.

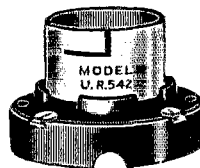

LIST
\$1.00

Special **50c ea.**

Dubilier High-Voltage Filter Condensers

(Newest Types, Nos. 902 and 903)

These Dubilier Filter Condensers are tested from 3 to 5 times their rated value, thus assuring a sturdy, scientifically designed product, far exceeding the average Filter Condensers now being used. Widely separated soldering lugs are provided to insure long leakage path and to facilitate neat wiring. Each condenser brand new and packed in individual cartons.

TYPE No. 902

Rated D.C. Working Voltage 400 V.

Capacity: 1 Mfd.

List Price \$2.50 ea. SPECIAL **75c ea.**

Capacity: 2 Mfd.

List Price \$3.50 **\$1.05**

Capacity: 4 Mfd.

List Price \$5.50 **\$1.65**



TYPE No. 903

Rated D.C. Working Voltage 600 V.

Capacity: 1 Mfd.

List Price \$3.00 ea. SPECIAL **90c ea.**

Capacity: 2 Mfd.

List Price \$5.50 **\$1.65**

Capacity: 4 Mfd.

List Price \$9.50 **\$2.85**

FILTER CHOKES

20 HENRIES

250 MILLS

Just what you want for obtaining a pure D. C. note for your Transmitter. Also can be used in "A" or "B" Eliminators.

Weight 5 pounds. Wiring heavily insulated. New and packed in individual cartons.

SPECIAL **\$2.50 ea.**

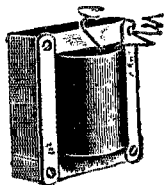

LAST MINUTE SPECIALS

R.C.A. Uni-Rectron Power Amplifiers — Model A. P. 935 List \$88.50 ea.	SPECIAL
E210 BRADLEYSTATS, list \$4.00, fine for A.C. Line Voltage Control	\$19.75 ea.
Genuine Black Bakelite Panels 38" x 43", 3-16" thick. Reg. Price \$29	1.60 "
U. S. ARMY Aeroplane Spark Transmitters, Gov. cost \$47 ea.	8.75 "
G. E. Kenotron Rectifying Tubes (Type T.B.1.)	4.75 "
Gould Kathanode Unipower, Automatic Radio "A" Power (6 volt), list \$39.50	1.25 "
G. E. V.T. 14 — 5 watt Transmitting Tubes (A good power amplifying tube)	13.75 "
Eby A. C. Adapter Harness with volume control for 6 tube sets. List \$10.00	1.50 "
	3.75 "

AMERICAN SALES CO., 19-21 Warren Street, New York City

McMURDO SILVER

Announces



Silver

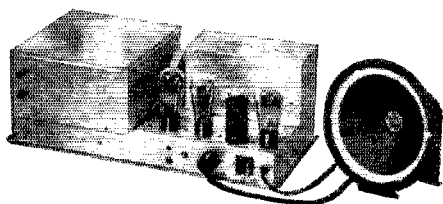

The SILVER RADIO chassis and speaker above is made complete in the new home of Silver-Marshall pictured below—the third largest exclusive radio plant in the Chicago area. The eight-tube Model 30 chassis (as furnished in Model 60 Lowboy and Model 95 Highboy) contains the fully shielded, non-oscillating Screen-Grid r.f. amplifier, with band selector, Screen-Grid power detector, push-pull power amplifier and A, B, C, and speaker power supply. It is a marvel of mechanical and electrical engineering. In all comparative tests so far, no other radio has been found which can even equal its performance.

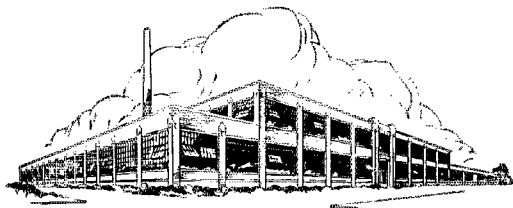

And now, at last, comes Silver-Marshall's entry into the complete R C A -Licensed radio receiver field with SILVER RADIO—the most sensational development since a.c. tubes revolutionized radio.

1929 is a Screen-Grid year. Its pace will be set by the new type radio that is SILVER RADIO—so original and so advanced technically as to be *utterly different from any other manufactured receiver*. For SILVER RADIO comes from a designer, a laboratory, and a factory that have *mastered* Screen-Grid technique—and *proved* it by chalking up unbroken records with the Sargent-Rayment Seven, and the famous Screen-Grid Sixes.

SILVER RADIO is nothing if not *new*. It is first to *eliminate all antenna installation*. It is first to use *three 224* a.c. Screen-Grid tubes as r.f. amplifiers with *band-selector tuning*, followed by a *fourth* Screen-Grid tube in the newest type of power detector circuit. SILVER RADIO is first to use a pair of 245 power tubes in push-pull; first to use a *matched impedance* dynamic speaker. And SILVER RADIO is first also with a startling development—the *Overtone Switch*, which brings out all the beauty of ordinarily-lost high notes as does no other radio—yet cuts them out at will to reduce static in bad weather. And prices—SILVER RADIO is first with prices so low that they actually make you gasp, even though they are made possible by tremendous production.

SM

**"Silver on Radio is like
SILVER-MARSHALL, Incorporated**

Radio

Just as a.c. tubes changed the "fashion" in radios from battery to light socket in 1927—just as surely will SILVER RADIO revolutionize public demand in 1929. For you know that the amazing new features of SILVER RADIO spell revolution in radio results—for distance, for selectivity, tone, convenience, and low cost.

Appreciation is due, and is in full measure given, to the many friends whose use and recommendation of S-M products has pushed SILVER-MARSHALL up into the position of dominating leadership in the parts field, now to launch forth, from one of the largest radio plants in America, the self-contained SILVER RADIO receivers. And Silver-Marshall has kept faith with these friends—SILVER RADIO is just the outstandingly superior product that they have always expected from the S-M laboratories.

SILVER RADIO will be distributed through leading jobbers to franchised dealers in exclusively allotted territories—backed by an unprecedentedly large newspaper advertising allowance per set, to "break" in the early summer. Dealer demonstrations are being arranged now, and franchise applications are being received.

Sterling on Silver™

6447 W. 65th St., Chicago, U.S.A.

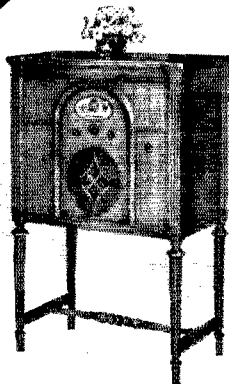

Model 60 Lowboy (above) and Model 95 Highboy (below) are finely built of striped walnut, in Sheraton period, finished in high-gloss lacquer. Both contain the same 8-tube a.c. Screen-Grid SILVER RADIO chassis, matched dynamic speaker, and screen antenna. They are absolutely complete, less only 4-24, 1-27, 2-45 and 1-80 tubes (list price of tubes, \$29.50). Model 60 Lowboy is priced at \$160; Model 95 Highboy at \$195 (slightly higher west of the Rockies). Both models operate on 100 to 130 volt, 50 to 60 cycle a.c. (25 cycle model special).



SILVER-MARSHALL, Inc.

6447 W. 65th Street, Chicago, U. S. A.

Send me the dope, and tell me where I can see and hear it—I'm interested.

Name.....

Address.....

City..... State.....

Use the New Jewell Trio In Your 1929 Transmitter!

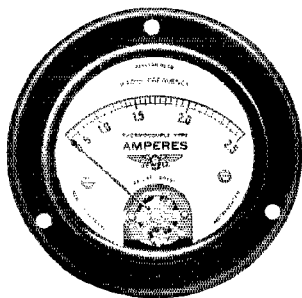

Pattern 68
Radio Frequency

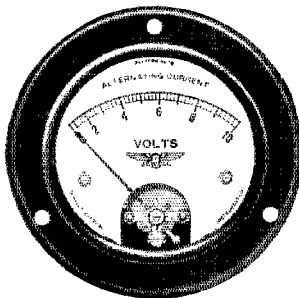

Pattern 78
Alternating Current

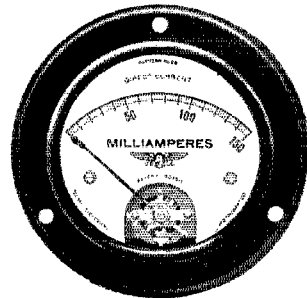

Pattern 88
Direct Current

The Jewell Trio in new bakelite cases, *at no extra cost*, is the answer to amateur broadcasters' dreams of perfect radio instruments.

Here are the instruments in cases of moulded bakelite that have been favorites with radio broadcasters and radio experimenters since the very beginning of popularized radio. These new bakelite cases combine high insulation with a permanent high finish, because there is no enamel to wear off.

These instruments are provided in an extensive variety of ranges and sizes that meet every radio need.

The Jewell Trio in bakelite cases is the latest in radio instruments and the finest equipment possible (*at no extra cost*) for your 1929 transmitter. If your dealer can't supply you, write us.

Jewell Electrical Instrument Company
1650 Walnut St. Chicago, Illinois

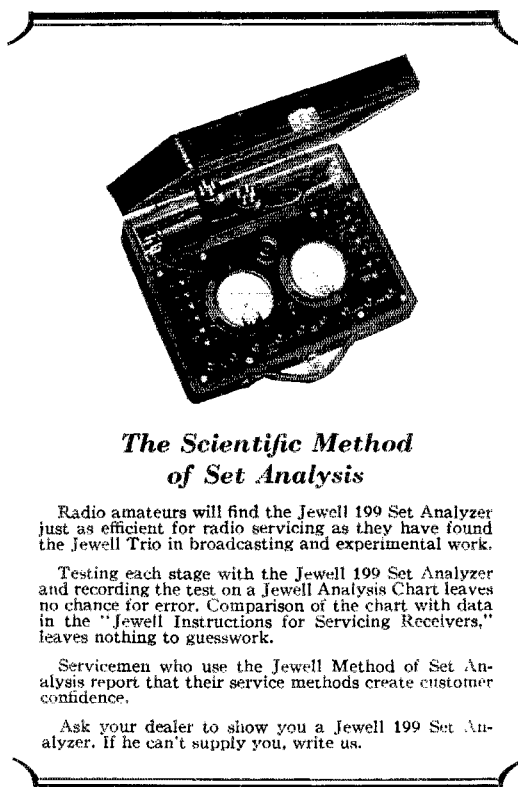

The Scientific Method of Set Analysis

Radio amateurs will find the Jewell 199 Set Analyzer just as efficient for radio servicing as they have found the Jewell Trio in broadcasting and experimental work.

Testing each stage with the Jewell 199 Set Analyzer and recording the test on a Jewell Analysis Chart leaves no chance for error. Comparison of the chart with data in the "Jewell Instructions for Servicing Receivers," leaves nothing to guesswork.

Servicemen who use the Jewell Method of Set Analysis report that their service methods create customer confidence.

Ask your dealer to show you a Jewell 199 Set Analyzer. If he can't supply you, write us.



Section Communications Managers of THE COMMUNICATIONS DEPARTMENT, A. R. R. L.

Eastern Pennsylvania*	W3ZF	ATLANTIC DIVISION	Don Lusk	3622 No. 15th St.	Phila.
Maryland-Delaware-District of Columbia*	W3BBW	Forrest Calhoun	M. J. Lotysh	1636 Thomas St.	Baltimore, Md.
Southern New Jersey	W3CFG	C. S. Taylor	A. W. McAuly	Box 49, R. F. D. 1	Cranbury, N. J.
Western New York	W8PJ			598 Masten St.	Buffalo
Western Pennsylvania	W8CEQ			309 Third St.	Oakmont
Illinois	W9APV	CENTRAL DIVISION	Fred J. Hinds	3337 Oak Park Blvd.	Beryvn
Indiana	W9CYQ	D. J. Angus	L. B. Wathen, III	310 N. Illinois St.	Indianapolis
Kentucky	W9BAZ	Dallas Wise	H. C. Storck	Mockingbird Valley	Louisville
Michigan	W8CFE	C. N. Crapo		0187 Falcon Ave.	Detroit
Ohio	W8BYN			094 Carpenter St.	Columbus
Wisconsin	W9VD			443 Newton Ave.	Milwaukee
North Dakota	W9DYY	DAKOTA DIVISION	B. S. Warner	309 4th Ave.	Enderlin
South Dakota	W9DGR	D. M. Pasek	Carl L. Jabs	700 Illinois St.	Huron
Northern Minnesota	W9BVK	J. C. Pehoushek		1822 James St.	St. Paul
Southern Minnesota	W9BKF			130 Warwick St., S. E.	Minneapolis
Arkansas	W5AHI	DELTA DIVISION	H. E. Velte	5408 U St.	Little Rock
Louisiana	W5EB	M. M. Hill	J. W. Gullett	1708 23rd Ave.	Oakdale
Mississippi	W5AKP	Polk Purdue		c/o Radio Station WBAW	Meridian
Tennessee	W4FI				Nashville
Eastern New York	W2CNS	HUDSON DIVISION	F. M. Holbrook	2 Livingston Ave.	White Plains
N. Y. C. & Long Island	W2KR	M. B. Kahn	A. G. Wester, Jr.	617 W. 141st St.	N. Y. C.
Northern New Jersey	W2WR			50 Princeton St.	Maplewood
Iowa	W9DZW	MIDWEST DIVISION	H. W. Kerr	915 Lincoln Ave.	Little Sioux
Kansas	W9CET	J. H. Amis	L. B. Litzure	8010 Mercier St.	Topeka
Missouri	W9RZ	C. B. Deihl		5605 Cedar St.	Kansas City
Nebraska	W9BYG				Omaha
Connecticut	W1ZL	NEW ENGLAND DIVISION	C. A. Weidenhammer	33 Washington Place	Bridgeport
Maine	W1RIG	Frederick Best	E. L. Battery	13 E. Crescent St.	Augusta
Eastern Massachusetts	W1UE	Dr. John A. Hessemmer	V. W. Hodge	39 Royal St.	Wollaston
Western Massachusetts	W1UM	C. N. Kraus		8 Schaffner St.	Worcester
New Hampshire	W1ATI	Clayton Paulette		227 Main St.	Claremont
Rhode Island	W1BCR			92 Keene St.	Providence
Vermont	W1IT				North Troy
Alaska	W7WDN	NORTHWESTERN DIVISION	W. B. Wilson	U. S. LHT Fern	Ketchikan
Idaho**	W7ABB	H. R. McBirney	O. W. Viers	1720 Washington St.	Boise
Montana	W7AAT-7QT	Wilbur S. Claypool	Otto Johnson	943 E. 30th St., S. E.	Red Lodge
Oregon	W7UN			3440 30th Ave. W.	Ped Land
Washington	W7FD				Seattle
Hawaii	K6CFQ	PACIFIC DIVISION	F. L. Fullaway	2714 Manoa Rd.	Honolulu
Nevada	W6DIO	C. B. Newcombe	D. C. Wallace	1348 Hanchett Ave.	Yerington
Los Angeles	W6AM	D. J. Quement	J. Walter Frates	209 Pine Ave., Room 410	Long Beach, Calif.
Santa Clara Valley	W6NX	C. F. Bane	Everett Davies	368 62nd St.	San Jose
East Bay	W6CZR	D. B. Lamb	M. I. Felizardo	262 Castro St.	Oakland
San Francisco	W6WB	Harry A. Ambler		1234 J St.	San Francisco
Sacramento Valley	W6DON			229 W. First St.	Sacramento
Arizona	W6ANO			252 Galicia St.	Mesa
Philippines*	K1AU			4101 Hamilton St.	Manila
San Diego*	W6EOP				San Diego
North Carolina	W4SJ	ROANOKE DIVISION	Enno Schuelke	R. F. D. No. 1	Ridgeway
Virginia	W3CA	J. F. Wohlford	F. D. Reynolds	118 Cambridge Ave.	Roanoke
West Virginia	W8VZ			Box 1200	Fairmont
Colorado	W9CAA	ROCKY MOUNTAIN DIVISION	C. R. Stedman	1641 Albion St.	Denver
Utah-Wyoming	W6BAJ	Parley N. James		430 "D" St.	Salt Lake City
Alabama	W4AAQ	SOUTHEASTERN DIVISION	S. J. Bayne	9 Park Ave.	Montgomery
Florida	W4AII	Harvey Chafin	James G. Cobble	6002 Suwanee Ave.	Tampa
Georgia-So. Carolina-Cuba-Porto Rico-Isle of Pine*	W4RM			627 State St., N. W.	Atlanta
Northern Texas	W5AKN	WEST GULF DIVISION	J. H. Robinson, Jr.	522 Cumberland St.	Dallas
Oklahoma	W5GF	W. J. Gentry	R. E. Franklin	610 Pottenger St.	Shawnee
Southern Texas	W5OX	L. E. Radka		1806 Valentine St.	Houston
New Mexico	W5TT				Tucumcari
Newfoundland	VE8AR	MARITIME DIVISION	Loyal Reid	Avalon House	St. Johns
New Brunswick	VE1E1	T. B. Lacey	A. M. Crowell	c/o N. B. Power Co.	St. John
Nova Scotia	VE1DQ	F. W. Hyndman		69 Dublin St.	Halifax
Prince Edward Island	VE1BZ			25 Fitzroy St.	Charlottetown, P. E. I.
Ontario	VE3FC	ONTARIO DIVISION	E. C. Thompson	266 Queensdale Ave.	Toronto, 6
Quebec	VE2BE	QUEBEC DIVISION	Alex Reid	169 Logan Ave.	St. Lambert
Alberta	VE4HA	VANALTA DIVISION	E. J. Taylor	10107-87th Ave.	Edmonton
British Columbia	VE5BJ	E. S. Brooks		2987 Camosun St.	Vancouver
Manitoba	VE4FV	PRAIRIE DIVISION	D. B. Sinclair	205 Cambridge St.	Winnipeg
Saskatchewan	VE4FC	W. J. Pickering		514 19th St. W.	Prince Albert

*Temporary official appointed to act until the membership of the Section concerned choose permanent SCMs by renomination and election.

**Acting for the summer.

FOR FIFTEEN YEARS

the General Radio Company has been manufacturing instruments for the amateur which have made a reputation for sound design, quality, and reliability. Among these are

Frequency Meters

Quartz Plates for

Piezo-Electric Oscillators

Audio Amplifier Transformers

Power-Supply Transformers

Variable Air Condensers (for
work on short waves)

New items are under development. Send for Bulletin 931-Q and ask to receive future announcements as they appear in the *General Radio Experimenter*

GENERAL RADIO COMPANY

30 STATE STREET

274 BRANNAN STREET

CAMBRIDGE, MASSACHUSETTS. SAN FRANCISCO, CALIFORNIA

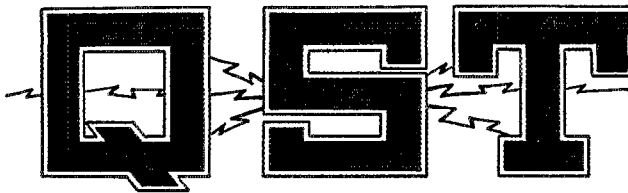

The Official Organ of the A.R.R.L.

VOLUME XIII

JUNE, 1929

NUMBER 6

Editorials	11
WHDC	<i>Stephens Miranda</i> 12
Photo-Electric Cells and Methods of Coupling to Vacuum Tubes <i>Thornton P. Dewhirst</i>	17
The President's Corner	<i>Hiram Percy Maxim</i> 21
The Pied Piper of Hamelin	<i>Uncle Jimmy</i> 22
Facts about Glass Arm	<i>Walter H. Candler</i> 26
Indicating Instruments for Amateur Transmitters	<i>D. J. Angus</i> 27
Re: An Approved Super-Heterodyne	<i>J. M. Grigg</i> 33
A New Monitor	34
Atlantic Division Convention	34
W8BQ	35
Book Reviews	<i>Harold P. Westman</i> 40
Two Recently Announced Tubes	<i>Harold P. Westman</i> 41
New England Division Convention	43
Experimenters' Section	44
How to Photograph Your Transmitter by Electric Lights	<i>E. H. Harrington, Jr.</i> 48
Communications Department	49
I.A.R.U. News	65
Calls Heard.	68
Correspondence	70
Hamads	92
Index of Advertisers	94

QST is published monthly by The American Radio Relay League, Inc., at Hartford, Conn., U. S. A. Official Organ of the A.R.R.L. and the International Amateur Radio Union

Kenneth B. Warner (Secretary, A.R.R.L.)
Editor-in-Chief and Business Manager

F. Cheyney Beekley
Managing Editor and Advertising Manager

Harold P. Westman
Technical Editor

James J. Lamb
Assistant Technical Editor

David H. Houghton
Circulation Manager

Subscription rate in United States and Possessions, Canada, and all countries in the American Postal Union, \$2.50 per year, postpaid. Single copies, 25 cents. Foreign countries not in American Postal Union, \$3.00 per year, postpaid. Remittances should be by international postal or express money order or bank draft negotiable in the U. S. and for an equivalent amount in U. S. funds.

Entered as second-class matter May 29, 1919, at the post office at Hartford, Connecticut, under the Act of March 3, 1879. Acceptance for mailing at special rate of postage provided for in section 1103, Act of October 3, 1917, authorized September 9, 1922. Additional entry at Concord, N. H., authorized February 21, 1929, under the Act of February 28, 1925.

Copyright 1929 by the American Radio Relay League, Inc. Title registered at United States Patent Office.
Member of the Radio Magazine Publishers' Association.

The American Radio Relay League

The American Radio Relay League, Inc., is a non-commercial association of radio amateurs, bonded for the promotion of interest in amateur radio communication and experimentation, for the relaying of messages by radio, for the advancement of the radio art and of the public welfare, for the representation of the radio amateur in legislative matters, and for the maintenance of fraternalism and a high standard of conduct.

It is an incorporated association without capital stock, chartered under the laws of Connecticut. Its affairs are governed by a Board of Directors, elected every two years by the general membership. The officers are elected or appointed by the Directors. The League is non-commercial and no one commercially engaged in the manufacture, sale or rental of radio apparatus is eligible to membership on its board.

"Of, by and for the amateur," it numbers within its ranks practically every worth-while amateur in the world and has a history of glorious achievement as the standard-bearer in amateur affairs.

Inquiries regarding membership are solicited. A bona fide interest in amateur radio is the only essential qualification; ownership of a transmitting station and knowledge of the code are not prerequisite. Correspondence should be addressed to the Secretary.

DIRECTORS

President
HIRAM PERCY MAXIM
Drawer 2102,
Hartford, Conn.

Vice-President
CHARLES H. STEWART
St. David's, Pa.

Canadian General Manager
A. H. K. RUSSELL
5 Mail Bldg.,
Toronto, Ont.

Atlantic Division
EUGENE C. WOODRUFF
234 W. Fairmount Ave.,
State College, Pa.

Central Division
CLYDE E. DARR
137 Hill Ave., Highland Park,
Detroit, Mich.

Dakota Division
C. M. JANSKY, JR.
Dept. of Elec. Eng., U. of M.
Minneapolis, Minn.

Delta Division
BENJ. F. PAINTER
424 Hamilton Nat'l Bank Bldg.,
Chattanooga, Tenn.

Hudson Division
A. LAFAYETTE WALSH
220 West 42d St.,
New York City

Midwest Division
PORTER H. QUINBY
817 Lauderman Building,
St. Louis, Mo.

New England Division
FREDERICK BEST
13 East Crescent St.,
Augusta, Maine

Northwestern Division
K. W. WEINGARTEN
3219 No. 24th St.,
Tacoma, Wash.

Pacific Division
ALLEN H. BABCOCK
65 Market St.,
Southern Pacific Co.,
San Francisco

Roanoke Division
W. TREDWAY GRAVELY
Box 245,
Danville, Va.

Rocky Mountain Division
PAUL M. SEGAL
Box 1771,
Denver, Colo.

Southeastern Division
HARRY F. DOBBS
245 Spring St., N. W.,
Atlanta, Ga.

West Gulf Division
FRANK M. CORLETT
2515 Catherine St.,
Dallas, Tex.

OFFICERS

President HIRAM PERCY MAXIM, Hartford, Conn.
Vice-President CHARLES H. STEWART, St. David's, Pa.
Secretary KENNETH B. WARNER, Hartford, Conn.
Treasurer ARTHUR A. HEBERT, Hartford, Conn.
Communications Manager F. EDWARD HANDY, Hartford, Conn.

ADDRESS ALL GENERAL CORRESPONDENCE TO THE EXECUTIVE HEADQUARTERS AT HARTFORD, CONN.

EDITORIALS

IN the "net" system of communication used by the Army and Navy and particularly exemplified by the Army-Amateur nets now in process of organization all over the country, there is an idea which, it seems to us, is worth investigating with a view to giving it a wider application in amateur radio generally. We refer to the basic fact that all the stations in any one such net use the same frequency. Thus the ultimate economy in frequency channels is realized.

Consider for a moment the fact that only by accident do two amateur stations, corresponding with each other, use the same frequency. Since one transmits while the other listens, it is apparent that twice as many channels are being used as are necessary, and from the standpoint of any third party there are twice as many interference possibilities to his own work. In other words, and to come immediately to the point, interference would be halved and the practical width of any amateur band doubled if the pairs of stations in communication with each other would use the same frequency.

Having launched this breath-taking idea, let us examine its possibilities a bit more closely, its potentialities both *pro* and *con*. Any such scheme would be most useful in our most crowded band, 7000-7300 kc. Our self-excited "High-C" transmitters of to-day are capable of changing frequency to any place in this band without difficulty, and by means of monitors we can quickly adjust them to any desired point, particularly with reference to some other station in the band. Here are the tools; now for the application. Suppose *A* calls *B* with the understanding that *B* shall answer on the same frequency. Then *A* knows just where to listen for *B* in the hubbub. More than that, *A* for the first time in history has control of the frequency used by his correspondent — something we have all yearned for — and he can deliberately choose a spot in the spectrum which, on his receiving tuner, is reasonably free of interference. That too is as it should be: *B*'s transmission ought to be on a frequency convenient to *A*'s reception. Now consider a chap CQ-ing. Suppose by some signal he indicates his intent to listen for replies near his own frequency. The stations answering him quickly shift their transmitters to about that wave. The CQ-er knows where to listen; he knows that, although the interference may be severe during the answering, it is going to be less afterwards; the answers know that they are not going to be left out in the cold because the CQ-er "started at the wrong end of the band" when he commenced listening and

"never got to" them; and the interruption to other amateur traffic is much less than happens now when fifty stations on fifty frequencies fill that elastic medium, the ether, with hopeful replies to a CQ. Again, imagine that we had an understanding in amateur radio that when a station signed off, it would stand by for new calls on its own frequency. How much greater the chance of QSO than now! Even in traffic work in the less-crowded 3500-4000 band the idea has application. Any group of message-handlers who work closely together may profitably ring some changes on the "five-point system" by some plan wherein they use a single frequency and transmit one at a time in turn, each fellow taking his own traffic, and so on.

So far we've talked *pros*. The *con* side, we admit, is full of dynamite. First off, we have lost the benefit of knowing the fixed frequencies of the stations we are interested in so that we can tell whether they are there or not. This, it seems to us, is offset by the potential gains of the plan, and a chap can always announce his return, after finishing a QSV-contact, to a normal frequency he has selected for himself and so again be "at home" to his friends. A far more vital objection to the scheme is the probability that increased interference would result from the frequent adjustments of frequency. Static in television would be nothing compared with the streaks of interference which could wipe across our bands as a hundred stations, preparing to answer a CQ, held down their keys and turned their knobs while they shifted frequency. This plan is only for those who know that they know how to use their heads. Both station equipment and operator's skill must be such that a shift to a monitored frequency can be made in, say, two seconds, and then only after the calling station has stopped. That way it would work.

Whether this idea is meritorious but too Utopian for 1929, hopeless because we amateurs are but human, dangerous because it hinders instead of aids, or actually capable of helping our communication — is to be determined only by trying it. It may be tried and found a flop, and QST in a few months may be yelling bloody murder against this very scheme, but it seems to-day very worth while trying. We urge those of you who can to give it a whirl — you and your buddy, you on your seven-o'clock sked with Bill Whatshisname, you on your contacts with your cousin on that Abyssinian expedition — and that you let A.R.R.L. Headquarters know whether you find it good, bad, or merely so-so. K. B. W.

WHDC

Aboard the *Nomad* on a World Cruise

By Stephens Miranda*

A FIFTY-FOOT boat does not offer the best of opportunities for the installation of radio receiving and transmitting equipment but when a trip around the world is planned, one does not care to set out without this most necessary item. This matter, therefore, received a good deal of attention when Daniel Blum and the writer determined to make such a voyage in the *Nomad*, a fifty-foot ketch-rigged double-ended sailing yacht. While normally proceeding under sail, the boat has a cruising radius of approximately 1500 miles under its own power generated by a two-cylinder fourcycle Frisco-Standard gas engine.

Space is only too scarce, particularly on a boat having a beam of but 13 feet, 6 inches, when such a long voyage is planned and in addition to the usual ship's stores and supplies, motion picture cameras, film, literary equipment and other special expeditionary gear must be stowed away.

However, a careful survey of the boat disclosed a cabinet four feet by three feet by twenty inches as being most suitable for the radio "shack" and the decision to use it put a strict, unalterable limitation upon the dimensions of the equipment that could be installed.

While a high-frequency transmitter and receiver would be capable of taking care of all messages to be sent home to the States regardless of the position of the *Nomad*, it would be of little worth for ship-to-shore work and obtaining radio compass bearings and weather reports or in handling distress calls. Because of this, it was

decided to carry not only the high-frequency equipment but also a medium-frequency transmitter and receiver capable of operating on the commercial frequencies of 500 and 469 kc. (600 and 640 meters). The two sets are complimentary to each other and have distinctly different fields of service; both are essential.

Unlike a land station, a ship's installation cannot sprawl about, be bulky or very heavy with-

out causing trouble. In addition it must be moisture proof, compact and solidly constructed as there is only so much room on a small boat and every inch must be utilized.

With these many restrictions in mind, the problem of selecting suitable equipment was attacked. Various circuits and arrangements were considered and many rejected because of their requiring critical adjustment or constant maintenance or being too complex for such a purpose. By a process of elimination we finally decided upon a combination whereby a single pair of 852's could be used for either high- or medium-frequency transmission by simply throwing a switch which connected their grids and plates to the proper

circuit. This idea was made practicable by means of three specially designed rotary switches operated from the front of the panel. These switches make possible the combining of two different types of transmitters with a common power supply, tube equipment and antenna system without materially complicating the construction or operation of the transmitter.

The use of a pair of 852's in a full-wave self-rectifying circuit was determined upon because

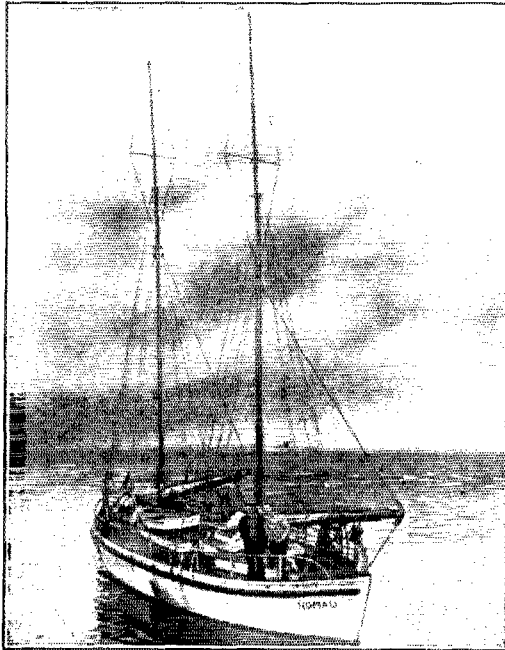

Photos courtesy *Nomad Expedition*
THE "NOMAD" JUST BEFORE THE START OF THE WORLD CRUISE

At the stern may be seen Daniel Blum and Stephens Miranda, the organizers of the expedition.

* 343 North Mansfield St., Los Angeles, Calif.

of the ease with which it was possible to obtain good operating conditions at the highest frequency to be employed. This is 12,500 kc. or 24 meters. While 203-A's would have allowed the use

to either 469 or 500 kc. The 500-kc. wave is used for calling and distress and the 469-kc. wave for all general commercial traffic as well as for calling. The switch to the right of this is the usual "send-receive" switch and carries in addition to the antenna connection, additional circuit contacts for closing the tube filament and motor-generator circuits when thrown in the "send" position and cuts them out in the "receive" position. The lower center switch changes the grid, plate and antenna circuits from the high- to the medium-frequency circuits or *vice-versa*. In operating, the procedure is simplicity itself. To transmit on the medium-frequency set, adjust the frequency-change switch to the frequency desired, set the lower center switch for medium-frequency operation and then throw the antenna switch to the "send" position and press the key. To transmit on the higher frequencies, it is only necessary to throw the center frequency-change switch to the high-frequency side. The aerial switch is left on the "send" side and the other switch ignored; it is automatically cut out of the circuit. The circuit diagram in Fig. 1 will indicate the manner in which these changes are accomplished.

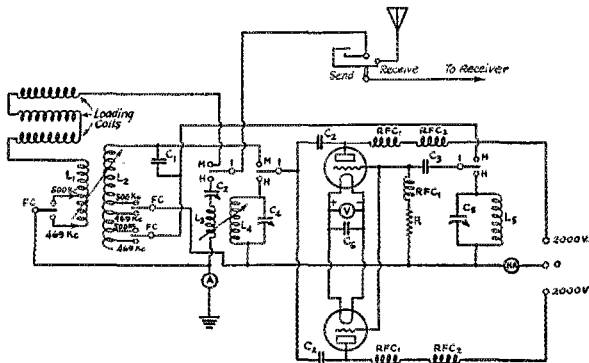

FIG. 1.—THE CIRCUIT ARRANGEMENT EMPLOYED IN THE TRANSMITTER IS SHOWN HERE

The three switches labelled 1 are controlled from a single knob and comprise one of the rotary switches referred to in the text. This is also true of the three switches marked FC. The antenna switch carries, in addition to the contacts shown, suitable switch blades to control the filament circuits of the transmitter and receiver and the starting circuit for the motor-generator supplying 500-cycle current for the transmitter. L1, L2 and the three loading coils used in conjunction with the medium-frequency transmitter are of the yaucake type but are shown as solenoids for clarity. L3, L4 and L5 are suitable coils of copper tubing and comprise the antenna, plate and grid coils of the tuned-grid, tuned-plate high-frequency transmitter. The other constants are as follows:

- C1 — .001- μ fd., 12,500-volt mica condenser.
- C2 — Two .002- μ fd., 5000-volt Sanyamo fixed condensers in series.
- C3 — .001- μ fd., 5000-volt Sanyamo.
- C4 — .0004- μ fd. Cardwell variable.
- C5 — .001- μ fd. Cardwell variable.
- C6 — .5- μ fd. fixed condenser.
- C7 — .0005- μ fd. Cardwell variable.
- R — 25,000 ohms.
- RFC1 — R.F. chokes for high frequencies.
- RFC2 — R.F. chokes for medium frequencies.

of lower plate voltage, they would not operate so smoothly at this frequency. In addition, a power increase of 50 watts was obtained with the 852's. They are rugged in construction and are suited admirably for operation on a small yacht where they will be under considerable mechanical as well as electrical strain.

A tuned-grid tuned-plate circuit is used for the high-frequency portion of the transmitter and operates at 5615, 8370 and 12,500 kc. (53.4, 35.8 and 24 meters). For the 469- and 500-kc. (640- and 600-meter) operation, a Hartley circuit is employed.

The circuit diagram and photographs show the constructional details of the transmitter. Three rotary fan switches are provided to facilitate changing from high to medium frequencies as well as to allow rapid shifting from one assigned wave to another. One of these is the change-over switch and takes care of all changes necessary when going from transmitting to receiving.

The rotary switch at the left on the transmitter panel changes the medium-frequency transmitter

On the high-frequency side, while assigned three frequencies, WHDC transmits on 12,500 kc. during daylight and on 8370 kc. during the evening hours. These two channels have been found most efficient at these respective hours of the day. Tuning of the high-frequency set is readily accomplished by means of the three control dials at the right of the transmitter panel, and the three meters at the left.

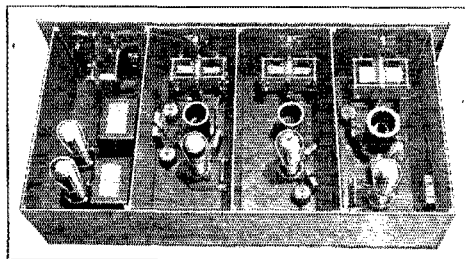

THE RECEIVER EMPLOYS A STAGE OF TUNED R.F. FOR THE HIGH FREQUENCIES AND A REGENERATIVE DETECTOR ONLY FOR THE LOWER FREQUENCIES

From left to right are the two-stage audio amplifier, high-frequency detector compartment, r.f. stage and medium-frequency detector. The various units are arranged in a simple manner and are well shielded from each other.

The upper dial controls the antenna circuit, the lower left tunes the plate circuit and the lower

right dial tunes the grid circuit. These dials are calibrated for the respective assigned frequencies and marked accordingly for facilitating rapid change to any of the three frequencies. Nevertheless, a frequency meter is constantly handy to keep a close check. Before each transmission

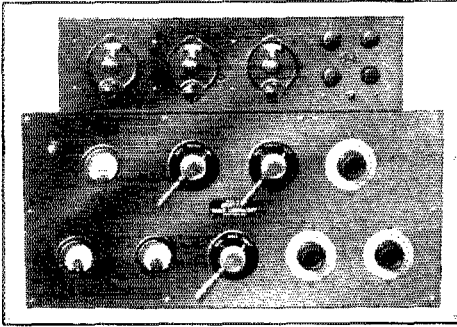

THE FRONT VIEW OF THE TRANSMITTER AND RECEIVER

The receiver is resting on top of the transmitter. The upper meter on the transmitter measures the antenna current while the lower two are for plate current and filament voltage. The upper left-hand switch may be set for either 469- or 500-kc. transmission while the lower switch connects the tubes and antenna to either the high- or medium-frequency transmitter circuits. The upper right-hand handle operates the "Send-Receive" switch. At the right end of the panel, the upper dial is for antenna tuning while the lower ones operate the plate and grid circuit tuning condensers.

period, all transmitting frequencies are checked to assure that rolling or jars have not changed the adjustments. Operating pride motivates accuracy in this respect.

The only tuning necessary in the medium-frequency set is the adjustment of the rotary switch determining whether the transmission frequency will be 469 or 500 kc. The two pancake helices in inductive relation to each other are permanently adjusted to the respective frequencies by tap-off clips as are the three pancake loading coils set at right angles to the other two. Extensive loading was necessary to boost the short antenna having a fundamental wave-length of 134 meters to 640 and 600 meters. It was a long climb! Tests are not yet completed but indications are that this medium-frequency equipment will exceed our expectations and give a fairly decent range even though it may be operating under such difficult handicaps. However, most of the medium-frequency work will be done at short range, the more dependable and trustworthy high-frequency transmitter being entrusted with the DX and heavy-duty work.

The power supply for the transmitter is located in the engine room, a space not over ten by eight feet, that contains an assortment of machinery seldom found on such a small craft. Along the forward port side and immediately aft of a partition of the radio cabinet, is the power supply con-

sisting of a Crocker-Wheeler 500-cycle motor-generator unit, the motor of which has been rewound to run from the 32-volt d. c. supply of the ship's Edison batteries. A suitable control panel is provided and carries the necessary d. c. and a. c. meters, auxiliary and main line switches and the field control for the radio motor-generator.

A battery of 25 cells of 112-ampere-hour Edison storage cells provides constant source of power. These may be charged by either a 2.5-kw. U. S. Motors marine lighting plant or a Westinghouse 1-kw. shunt generator driven by the main propelling engine through a belt. In addition to this equipment, this tiny room also contains the main propelling engine, storage tanks for 130 gallons of water, 520 gallons of gas and 50 gallons of lubricating oil; an ice refrigeration generator driven by a 32-volt motor; bilge pumps and an auxiliary gravity-feed tank for emergency use with the main lighting plant. It is easily seen that not an inch of space is wasted, yet with all this equipment installed there is still ample room for a two-foot passage around the main propelling plant and all apparatus is readily accessible for adjustment and repair.

It is extremely desirable to have more than a single source of energy for the transmitter and in this case there are four separate power sources. The motor-generator may be driven by the 2.5-kw. lighting plant directly with the batteries floating on the line and charging; it can be excited by the 1-kw. Westinghouse generator driven by the main propelling engine with the battery

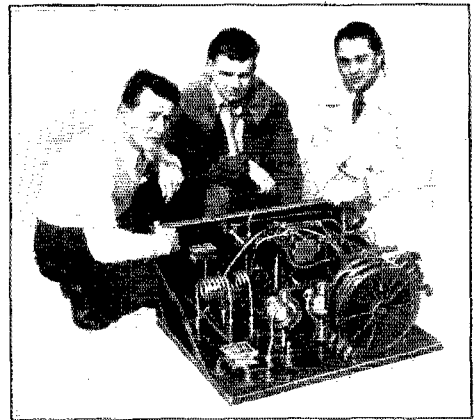

A REAR VIEW OF THE TRANSMITTER

From left to right are Stephens Miranda, operator of WHDC; Otto Johnson, W7FD, designer and builder of the equipment; and Daniel Blum, the other organizer of the expedition.

across the line; or the battery may be used directly with both generating plants inoperative; and lastly, any 110-volt a. c. city supply may be used without the motor-generator running. This

last arrangement is made possible through the use of a 750-watt 60-cycle transformer which is normally used with the 500-cycle supply from the motor-generator. This is an important factor and permits WHDC to use city supply whenever docked and such is available.

As might be anticipated, the problem of designing an antenna system to be strung in such limited quarters and capable of radiating at such widely different frequency bands was not a simple one. Designing for one service seemed possible only to the detriment of the other. A four-wire flat-top inverted L of 22 feet was first erected. It was suspended between two seven-foot spreaders on the ship's masts, being about 55 feet high at one end and 45 feet high at the lead-in. The lead-in was strung on stand-off insulators directly down the mast to the engine room skylight where it passed through pyrex insulators across the room to a lightning switch mounted over the motor-generator control panel.

Tests with this radiator developed four dis-

of the antenna suspended at such a height above the body of the boat. Secondly, when under weigh and rolling, operation of either transmitter or receiver was impossible due to extreme signal swinging. Thirdly, the stand-off insulators impaired the facilities for lowering and raising the mizzen sail as it runs on hoops up the main mast. Lastly, while the flat-top benefited the efficiency of the medium-frequency set, it did not allow good tuning conditions to be obtained with the high-frequency transmitter.

In place of the flat-top, we tried a cage antenna consisting of 12 wires twisted together in groups of three so as to form a four-wire system approximately 21 feet long and 12 inches in diameter with a 48-foot single-wire lead-in run directly from the cage-end to the engine room skylight lead-in insulator as before excepting that no stand-off insulators are necessary. The fundamental of this system was 134 meters.

The ground consists of a connection to the main propelling engine and another through the hull to two copper plates mounted on either side of the propeller. These two plates are connected together by a welded copper strip which also passes over the propeller shafting thus connecting it to the internal ground on the main engine.

With this radiating system the effects of rolling are noticeably less. Stations which previously came in fair only to fade out entirely when the boat rolled now came in strongly and showed very little swinging or fading except in an unusually bad sea-way. Over 100 stations have been copied at a distance of 5000 to 8000 miles with signal strength of R8 and R9 (QSA3-5). Likewise in transmission where difficulty was previously experienced in "getting out" we have established excellent communications working from Seattle while docked beside the Jensen Motorboat Corp. QRN in this district is extreme due to power lines, local conditions and propelling machinery of small boats that ply back and forth on Lake Union within a hundred yards or so of the *Nomad*. However, WHDC has worked stations in New Bedford, Mass.; Charleston, Va.; Honolulu; New Zealand; Lafayette, Ind.; Chicago; San Francisco and Los Angeles. This is to be considered as quite excellent when

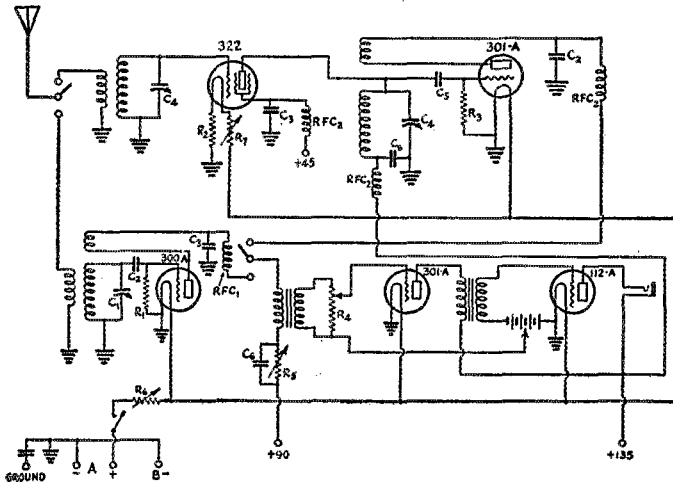

FIG. 2.—THE COMBINATION CIRCUIT FOR THE TWO RECEIVERS APPEARS ABOVE

The two switches are a single unit and shift the audio amplifier and antenna to the desired detector circuits. The constants are:

- C1 — 350- μ fd. taper-plate Cardwell.
- C2 — 500- μ fd. Aerovox fixed condenser.
- C3 — 2000- μ fd. Aerovox fixed condenser.
- C4 — 150- μ fd. taper-plate Cardwell.
- C5 — 150- μ fd. Aerovox fixed condenser.
- C6 — 1- μ fd. Tobe by-pass condenser.
- R1 — 5-meg Durham leak.
- R2 — 15-ohm Carter resistor.
- R3 — 8-meg Durham leak.
- R4 — 500,000-ohm Carter potentiometer.
- R5 — 300,000-ohm Carter variable resistor.
- R6 — 10-ohm rheostat.
- R7 — 50-ohm rheostat.
- RFC1 — Silver-Marshall No. 276 choke.
- RFC2 — Silver-Marshall No. 275 choke.

The plug-in coils are Silver-Marshall as are the audio transformers.

tinct faults. The worst of these was the loss of balance of the ship caused by the bulky weight

it is remembered that WHDC transmits entirely out of the amateur bands. In general amateurs do not usually listen on the frequencies assigned for operation to WHDC and many calls have undoubtedly gone unacknowledged because of this.

The receivers are not quite so complex as is the transmitter. They do, though, involve the same principles in that the medium- and high-



THE RADIO "SHACK" IS A CABINET AS MAY BE SEEN ABOVE

The transmitter is mounted above the receiver and the lower portion of the cabinet cover becomes a writing table when let down.

frequency sets are combined in one cabinet and a single switch is used to change from one set to the other. Tuning is accomplished by means of three dials that control the entire frequency range of both sets.

Plug-in coils are provided and the high-frequency receiver which employs a stage of tuned r.f. amplification using a screen-grid tube covers from 2700 kc. to 18,750 kc. The medium-frequency receiver used a straight regenerative detector employing a C-300-A tube. It covers from 200 to 1500 kc. A two-stage audio amplifier having a 112-A as the last tube is common to both sets. This makes the sets suitable for broadcast reception when that is desired.

The first tuning dial at the left end of the receiver panel controls the medium-frequency regenerative detector. The remaining two dials are for the high-frequency detector and r.f. amplifier. The four small knobs at the extreme right of the panel are the various tube controls. The upper left controls the filament circuit of the screen-grid tube while the upper right takes care of all tube filaments. The lower left knob is the resistance control of regeneration and the remaining knob is for the potentiometer which acts as the volume control. In the center of these four knobs may be seen the double-throw telephone-

keyboard switch by means of which the audio amplifier and antenna circuits are connected to the proper r.f. circuits.

The designer and builder of WHDC is Otto Johnson, W7FD, of the Seattle Radio Laboratories. He is also the Section Communications Manager of the Washington Section and requires no additional introduction to League members.

The *Nomad* sailed from Seattle on March 10th and reached San Francisco after fourteen days on a storm-ridden sea during which it rode out over forty squalls of hurricane force. After a short stop-over we will proceed to Los Angeles where motion picture equipment will be taken aboard. A schedule will then be decided upon between Charles Hill, W6BRO, who has completely rebuilt his station in order to be prepared for the handling of the many schedules to be run, and the writer. Hill will be the official contact man of the expedition.

After these matters are attended to, the *Nomad* will embark under the auspices of the Adventurers of the World, an international explorers club, for the Mexican coast and Panama.

The itinerary will then take the ship in its search for unusual literary and photographic data to the South Seas where it will call at the Marquesas, New Hebrides, New Guinea, New Zealand and other islands in the South Pacific group. From there the plan is to beat our way to Australia, the Philippines, China, and Japan. Following this we sail along Siam, Africa, and thence to the Mediterranean sea-ports, finally reaching the North Sea. In turn, the Continental countries will be visited.

The return to America will be made by way of the South Atlantic via Brazil. We will sail up

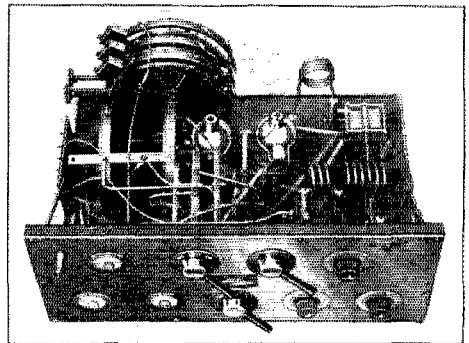

A TOP VIEW OF THE TRANSMITTING SET

The high-frequency equipment is to the right while the larger pancake inductances are employed for the 500-kc. portion of the set. The long handles on the panel control the switches for changing from transmitting to receiving and also determine the frequency of transmission.

the east coast of this country to Cuba, thence setting our course through the Panama Canal and

(Continued on page 82)

Photo-Electric Cells and Methods of Coupling to Vacuum Tubes

By Thornton P. Dewhirst*

THE photo-electric cell has grown to be a well known article in the last few years and with the advent of talking movies, radio photos, telephoned pictures, and increased activity in television experiments, promises to become a very important piece of apparatus to every experimenter.

The cell is a device for changing light values into electrical values. Probably selenium is the best known device of this kind. The alkali-metal cell, however, differs radically from the selenium

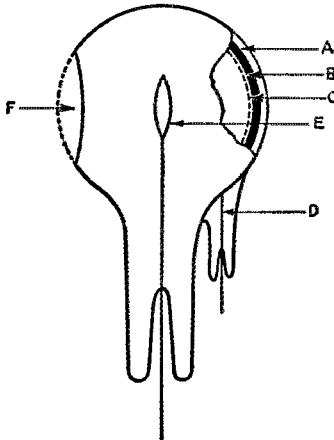

FIG. 1.—THE GENERAL CONSTRUCTIONAL DETAILS OF A PHOTO-ELECTRIC CELL ARE SHOWN ABOVE

The glass envelope, A, which is usually of pyrex or quartz is coated on the inside with a deposit of silver, B. Upon the silver is a film of the light-sensitive material, C. At D is a wire embedded in the glass and making contact to the silver coating which is the cathode. The anode, E, is a ring or loop of wire and is supported from a stem through which the lead wire passes. A window, F, is cleared of silver and allows the light to enter the cell and affect the light sensitive material. The envelope may be highly evacuated or may be filled with gas at low pressure.

cell and when light is incident upon the sensitive material it liberates electrons which are attracted to an electrode provided for that purpose.

Fig. 1 shows the general construction of such a cell. It consists principally of a glass container which is commonly made of quartz or pyrex. This type of glass permits the passage of ultra-violet light to which the cells are very sensitive.

This shell is baked and de-gassed and a silver coating deposited on the inside of the bulb. Contact is made to this silver coating by means of a

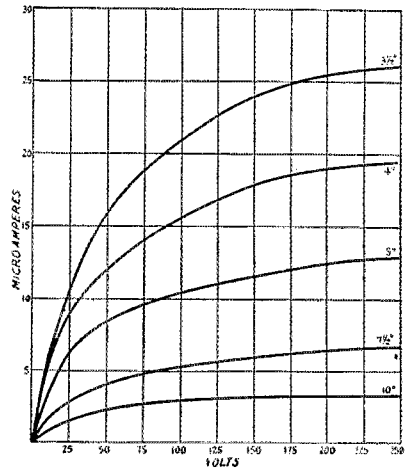

FIG. 2.—THESE ARE CHARACTERISTIC CURVES FOR A HIGH-VACUUM CELL

They give the current through the cell for varying voltages impressed across it. The source of light employed was approximately equivalent to a 200-watt Mazda lamp operated at 115 volts. The numbers on the curves indicate the distance between the source of light and the cell in inches.

wire embedded in the glass and the metal, potassium, is caused to be deposited on the silver surface. Hydrogen is now forced into the tube and a glow discharge produces the desired potassium-hydride surface. This glow discharge is maintained between the surface above referred to which is known as the cathode and a centrally located metal ring. The metal ring, known as the anode, is shown in the figure and is made positive. It is the electrode to which the electrons are attracted under the influence of the cell battery.

As is indicated in the figure a window is made in the light sensitive material by the application of a torch to the desired surface during the process of manufacture. It provides a means of admitting light to the interior of the bulb so that it might fall upon the light sensitive material. The bulb is pumped free of hydrogen and sealed up, in the case of high-vacuum cells. In the case of gas cells, after the hydrogen is exhausted, argon gas is admitted to a given pressure and the tube sealed off.

*Radio Consultant, 4909 7th St., N. W., Washington, D. C.

Regarding the operation of the cells, the potassium-hydride surface and the silver coating upon which it is deposited, together, might well be compared to the filament of a vacuum tube in that it is the source from which the electrons flow to the collector ring which would then correspond to the plate of a two-element tube. The number of electrons available, however, is exceedingly small compared to that available from a tube filament.

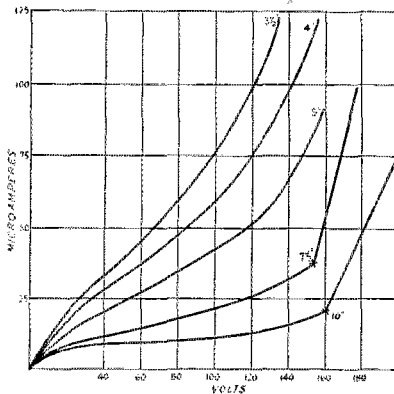

FIG. 3.— THESE CHARACTERISTIC CURVES ARE FOR A GAS-FILLED CELL

The source of light in this case was approximately equal to a 100-watt Mazda lamp operated at 115 volts. It will be apparent from these curves that although a lower maximum voltage is applied to the cell and the source of illumination is weaker, the currents obtained are much greater than for the high-vacuum cells. As in Fig. 2, the distance between the cell and the source of light is indicated on the curves.

As stated above, two standard types of cells are in general use. The high-vacuum type whose response is linear over a considerable range, but the output of which is rather low; and the gas-filled type which, while rather limited in linear response range, furnishes a much greater output.

Fig. 2 shows the characteristics of the high-vacuum type cell. The numbers on the curves indicate the distance in inches between the source of light and the cell. We see that as we increase the cell voltage, the illumination remaining constant, the current output increases up to a certain point after which it remains rather constant. Also we note that as the light is made more intense (moved closer) we get an increased current.

The curve shown in Fig. 3, which is for the gas-filled variety, also shows the same characteristics with the exception that the output is greater and as we increase the voltage the rise in current is more rapid. One important fact to be guarded against when using this type of cell is that as the voltage is increased near to the ionizing potential of the gas, a strong light will cause the cell to glow. This glowing is harmful to the cell and the cell should not be left in this condition for any length of time. It will be necessary to remove the voltage applied to the cell before this glow will

disappear; the mere removal of the light does not stop the cell from glowing. For every combination of light and voltage above a certain limit there is a point at which gas cells will glow.

To show the linear characteristics of the photoelectric cell, we can take the family of curves shown in Fig. 2, and cross plot from them and get the curve shown in Fig. 4. This curve is obtained by plotting the current output of the cell at a fixed voltage against the distance between the source of light and the cell, the brilliance of the source remaining constant. If, now, we take this curve and change the constant light source and variable distance into light intensity ratios, we can readily see that the response is directly proportional to the light flux incident to the cell as shown in Fig. 5. To obtain this light intensity ratio, as used above, we can use the formula:

$$I = \frac{K}{d^2}$$

where K is a constant and d is distance. For simplicity, we will assume K equal to 1, and our formula merely states that the light flux is inversely proportional to the distance squared.

For instance, in order to obtain Fig. 4, we took a point on the abscissa of Fig. 2, which represented a voltage of 175 volts and found the value of current corresponding to the different distances. When these values are plotted on a distance versus current output graph, Fig. 4, is the result.

Now, to obtain Fig. 5, we apply the formula given above. For a distance of 10 inches

$$I = \frac{1}{10^2} \text{ or } 0.01; \text{ for 5 inches, } I = \frac{1}{5^2}$$

or 0.04; and so on. Next we plot these values on a light intensity versus output graph; and in so doing, we obtain the values shown in Fig. 5,

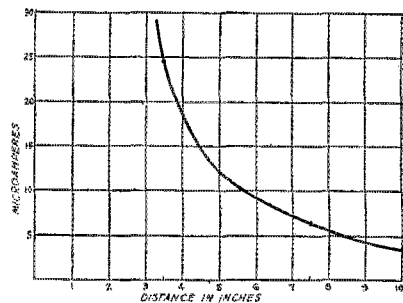

FIG. 4.— This curve is for a high-vacuum cell and shows the relationship between the current output of the cell and the distance between the cell and the source of illumination which is approximately equivalent to a 300-watt Mazda lamp operated at 115 volts.

indicating that the current is directly proportional to the intensity of light falling on the cell.

We might have calculated the light flux falling on the cell in lumens in each instance in which case the curve or more correctly the rectilinear

graph of Fig. 5, would have been arrived at directly. However, such a procedure would have involved more calculations and no doubt would not have been near so instructive as the above. Also, in the above, neither the intensity of the light source, nor the size of the aperture entered into the calculations directly. Nevertheless it might be well to say here that it is now becoming common practice to grade cells in microamperes per lumen. To define a lumen technically or mathematically would involve considerable calculation and a multitude of definitions and since we avoided that above we shall let it suffice to say that the light passing through an aperture or falling on a surface one and one-half inches square

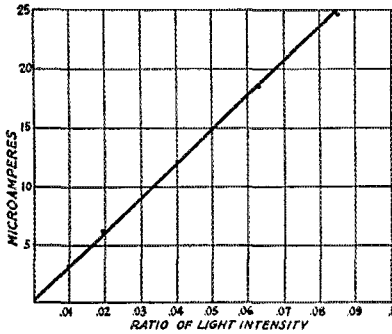

FIG. 5.— THE RATIO OF LIGHT INTENSITY IS HERE PLOTTED AGAINST THE OUTPUT CURRENT

In this particular case the relationship is linear and indicates that little or no distortion would be caused due to a change in the intensity of the illumination. This, of course, considers only the cell and takes no consideration of distortion that may occur in the electrical equipment associated with it in general operation.

placed ten inches from a 150-watt lamp operated at 115 volts is approximately one lumen.

It will be noted that the response of the cell described is practically directly proportional to the illumination at any voltage above 150 volts.

However, in the case of the gas-filled cells, which are most generally used in television and sound pictures, it will be found that the linear response is not so easily obtained. With special care in their construction and manufacture and if operated at the proper voltage in a given range of light values, there can generally be found a range over which the illumination current relationship may be kept linear. The gas-filled cells give approximately ten times as much output as the vacuum type cells; outputs ranging from five to fifteen micro-amperes per lumen being rather easy to produce. The reason for this increased output is due to the fact that as the electrons emitted from the potassium travel toward the anode, some of them collide with molecules of the gas with which the cell is filled. The result of such a collision is usually that one or more of the electrons of the molecule is knocked out of its orbit

and leaves the molecule. Instead of just the original electron traveling on to the anode we may now have two or more electrons going there. In addition to the increased number of electrons

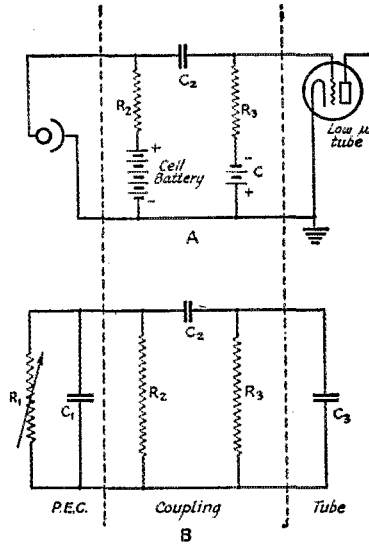

FIG. 6.— THE UPPER PORTION LABELLED A GIVES THE SCHEMATIC DIAGRAM OF THE COUPLING BETWEEN THE CELL AND THE GRID OF THE TRIOD

In the lower figure, B, appears the equivalent network for this. C_1 and R_1 replace the photo-electric cell and C_3 corresponds to the input capacitance of the triod.

reaching the anode, the molecule which lost an electron or two becomes, because of this deficiency, positively charged and travels to the cathode which is the most negative body in the cell.

If the number of electrons liberated from the cathode becomes too great for the space within the cell and causes too many collisions or if the voltage across the electrodes is increased beyond a certain critical value and allows the electrons traveling between cathode and anode to reach too high a velocity, thus increasing the number of electrons that can be knocked out of the gas molecules, the gas will become completely ionized and will glow. This ionization has been referred to above and is not an operating condition of the cell; it is damaging and should be avoided.

Some typical curves of gas-filled cells are shown in Fig. 3.

So much for the cells themselves. Let us now consider the method of connecting them to a vacuum tube so that we may amplify their output. First we have in the cell circuit a polarizing battery to draw the electrons from the sensitive material. In order to accomplish this we make the electron emitting metal negative and connect the positive of the battery to the remaining electrode,

generally the center one, which we have called the anode. In series with the polarizing battery we now place a resistor, the drop across which we expect to utilize. Upon first consideration we would make this resistor rather high in order to

cell battery which causes a current to flow through them. This current causes a certain voltage drop across R_2 which is applied to the grid of the tube. As the resistance of the cell varies with the amount of incident light, the current from the battery varies and the drop across R_2 varies. It is this varying voltage across R_2 that is responsible for the signal applied to the grid of the tube.

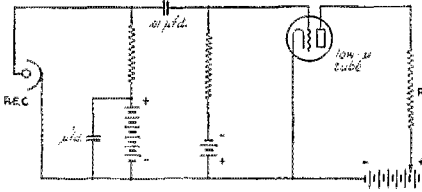

FIG. 7. — A GOOD CIRCUIT FOR GENERAL TELEVISION WORK IS GIVEN ABOVE WITH CONSTANTS INDICATED

The tube may be a 171-A, 112-A or 201-A with preference to the first mentioned one. A 199 or WX-12 will give an increased gain but will result in a slight sacrifice in the linearity of the frequency response. The plate resistor, R_1 , will vary between 5,000 and 50,000 ohms depending upon the tube and plate voltage.

produce the so-called "match" between the cell and the load. However, upon still further consideration we find that the value must be relatively low unless we are dealing with low frequencies such as encountered in relay action, in which case only the precaution in regard to leakage need be observed. That is, the value of resistance must not be so high that the tube leakage and possibly the resistor mounting possesses a resistance comparable to the value of the resistor itself. Let us complete the coupling to the tube and then return to the various factors affecting the choice of values for the several elements. From the polarizing resistor we will couple through a condenser and grid leak to the tube in the regular fashion used in resistance-capacitance amplifiers. This tube should be of as low a μ as possible when high frequencies are to be amplified.

C_3 is the coupling condenser which prevents the voltage of the cell battery from being applied to the grid of the vacuum tube and R_3 is the gridleak through which grid bias is obtained. In Fig. 6B, R_1 denotes the resistance of the cell and C_3 is the input capacity of the triod.

We will now consider the circuit in regard to the values required to cover a wide range of frequencies. In regard to the choice of R_2 , as stated above, we would like to make this resistance as large as possible in order to have a large voltage available. We must not, however, make it so large as to produce an appreciable voltage drop and thus affect the polarizing potential applied to the cell and possibly introduce distortion. Also it should not be so high as to compare favorably with the reactance of C_1 at the highest frequencies

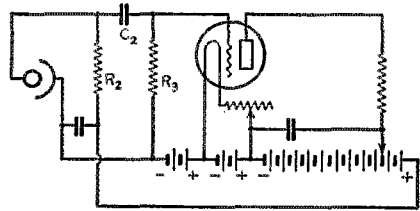

FIG. 8. — This arrangement makes it possible to employ the same battery to supply voltage to the plate of the triod and the photo-electric cell at the same time. If this circuit is used for operating a relay, R_2 and C_2 should be large and R_3 rather small.

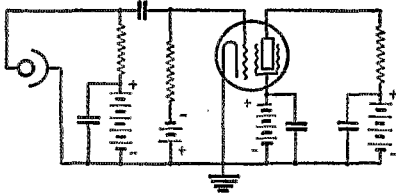

FIG. 9. — If a linear frequency response is not essential, it is possible to obtain an enormous gain by the employment of a screen-grid tube. Such an arrangement is shown above.

The circuit we now have is shown in Fig. 6A and its equivalent is shown at B of the same figure. Here the PEC (photo electric cell) is considered as a small capacity, C_1 , which is shunted by a high resistance, R_1 . The resistance of the cell is dependent upon the voltage across it and the amount of illumination it receives. R_2 is in series with the cell and the two are shunted across the

desired. This is a consideration of extreme importance in dealing with large cells. A low value of R_2 also helps the high frequency response on the tube end, that is relative to C_3 , which is the input capacity of the tube; R_2 and R_3 may be considered as in parallel in respect to this capacity and therefore the lower this value the better the response at the high frequencies. The use of a high- μ tube is accordingly undesirable because its input capacitance will be large as is indicated by the formula:

$$C_i = C_{gf} + (\mu + 1) C_{gp}$$

where C_i = effective input capacity
 C_{gf} = grid to filament capacity
 C_{gp} = grid to plate capacity
 μ = amplification factor of the tube.

If a flat response is not so essential over a given band of frequencies the value of R_2 may be increased and a corresponding gain in output in the medium-frequency range produced. Here a high- μ tube might even be used to considerable advantage.



The President's Corner

A WORD FROM

HIRAM PERCY MAXIM

PRESIDENT OF THE AMERICAN RADIO RELAY LEAGUE AND
OF THE INTERNATIONAL AMATEUR RADIO UNION

Self-Control

SOMETIMES I marvel that amateur radio has attained the high place it occupies. Considering what easily might have happened in all these years, it almost seems as though amateur radio were a child of destiny.

We amateurs could interfere with and seriously disturb every form of radio communication. There is no highly-organized police system constantly watching to prevent us. There are thousands and thousands of us. Notwithstanding, we have an unbroken record of fourteen years of improving prestige. In the United States we are regarded as an important national asset, and when an international radio congress convenes our government gives us the full weight of its influence to help us maintain all the space in the spectrum that can be got. The years of consistent high-quality conduct have won this.

Among the older ones of us, it is not surprising that an orderly behavior should have been maintained. We older men know from hard experience the losses that follow behavior not for the general good. But most of us are young and cannot yet have learned this most important of all life's lessons. And what is more, fresh groups of young fellows join us every year. They cannot have acquired the traditions of amateur radio and the A. R. R. L.

And yet, something is conveyed to every one who enters amateur radio that makes him keep in line.

What is it? Whatever it is, let's preserve it. It has worked marvels for fourteen years.

In choosing the value of C_2 and R_3 for maximum response at high frequencies, C_2 should be small in order to minimize the capacity of the condenser to ground which would be large for a large condenser due to its physical size. At this point it might be well to say that all wires should be as short as possible and run as free from other wires and apparatus as is convenient; also all shielding should be well spaced from these leads — never use braided shielding or lead covered wire but run the leads down the center of an over-size piece of tubing, say 1" in diameter — in order to minimize the capacity to ground. To get back to where we started, we chose a small condenser, therefore, the value of R_2 must be rather large in order to bring up the low frequency response. There is always room for a considerable amount of juggling here, since we make the value of R_3 extremely large we begin to affect the high frequency response on the tube side because of C_3 . Making C_2 larger will let us make R_3 smaller and may be desirable in some cases.

The choice outlined above of small R_2 , small C_2 , fairly large R_3 and a low- μ tube will be found to give extremely satisfactory results, when covering a wide band of frequencies.

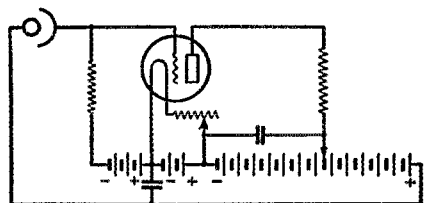

FIG. 10. — This is a still simpler arrangement for operating a relay by means of the cell. It is not as sensitive as Fig. 9 because a single resistor acts as grid leak and carries the polarizing current as well.

In regard to the rest of the amplifier little needs to be said; make sure that it has the frequency response desired. Well designed transformers may

(Continued on page 25)

The Pied Piper of Hamelin

A "1929" Edition of an Old Story

By Uncle Jimmy

DEAR, dear little Hams: Settle the cans over your ears and make yourselves comfy, because Uncle Jimmy is at the mike and he's going to tell you a darling little bedtime story. You won't have to go to bed right away after the story, either, for Uncle Jimmy wants to talk to you kinda serious and he has asked Mamma and Papa Ham (Ma and T.O.M.) to let you stay up a little longer tonite.

Well sir, it was a funny thing that happened to your old Uncle Jimmy. Maybe I went to sleep with the cans on — maybe not — but, anyway, I tuned in an honest-to-goodness *fairy!* It was a little fairy ham right from Hamelin Town. I knew right off that it was the Pied Piper, himself:

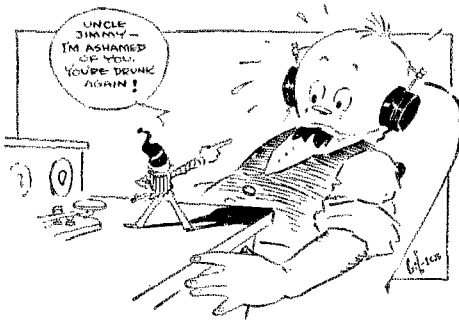

I knew him by his sweet little d.c. note. It was that note, you know, that made all the little Hams follow him around like they did in the story-books.

The Piper was a funny little fellow, not much taller than the receiver panel, and I couldn't help but laugh when he attempted to scowl at me. That little face wasn't meant for scowling. He stamped his little foot angrily and spoke: "Uncle Jimmy, I'm ashamed of you. You're drunk again!" Well, that sorta got me because I was sober as a judge and I never touched hard liquor anyway. I was just a little provoked.

Now fairies are queer folks; they can read your thoughts like so much Continental. Piper gave me another hard look and went on: "Don't get uppish; you know what I mean. You're on a mental drunk. You have a lot of unorthodox ideas about radio an' I'm here to tell you you better get rid of 'em if you want to ever amount to anything! First thing you know, the Who's Who in

radio will say 'thumbs down' and you'll be out of a job —.

"But wait! I can see by your thoughts that you're not in the radio business; you're just a ham and, as such, are entitled to all the crazy notions you like. Well, well; I'm sorry!"

We shook hands merrily. Piper laughed till he wabbulated. "Gosh, that was a funny mistake," he said. "You know I read some of your stuff in QST and I thought I'd better come around and warn you that you were skating on the same sort of ice as was the preacher who wanted to hold dances in the church gymnasium."

Piper's merry little eyes twinkled as he took a slip of paper out of his tiny pocket. "Since you're not one of the preachers, I can show you a cartoon I drew. It's called Fig. 1 and it's supposed to represent a horizontal Hertz. It's all out of shape so that a fellow can see its innards. The little dots represent free electrons that have been magnified a few billion times.

"At A, the Hertz is supposed to have somehow received an electrical jolt which forced a lot of the free electrons to one end of the antenna. The electrons are all negative and they don't like being squeezed together because like things repel. The natural tendency of these electrons is to redistribute themselves evenly throughout the conductor. We call this tendency capacitative reactance.

"Inductive reactance is like the country politician. It's 'agin' everything! It puts up a stiff fight at first and finally yields completely, being the reverse of capacitative reactance which resists but gently at first and finally brings the electronic procession to a complete halt.

"The aim of capacitative reactance is to bring the electrons from the position of A to that of B and there to stop. Inductive reactance is 'agin' starting, but finally yields and, when the objective is reached, is 'agin' stopping, so that the procession travels on until again stopped as at C by capacitative reactance."

Piper stopped and looked into my eyes mischievously. "See anything wrong with the picture so far?" he asked.

"Why — uh — yes," I replied. "The textbooks always have dotted lines drawn between antenna and ground to show where the capacity comes in. You know you have to have both capacity and inductance to tune a cir —."

"No, I don't know any such thing!" he broke in. "Of course, both capacity and inductance are

going to be present in any circuit — tuned or otherwise — but let's just *suppose* that we can eliminate capacity entirely. The circuit will still be tuned because it will possess capacitative and inductive *reactance* — that's what counts.

"The effect of capacity is shown at D. The crowded electrons in the left leg can see two ways of returning to a normal balance, but only one way is possible because of the insulating gap. The attraction across the gap serves to cause a little delay — reduces the frequency.

"Here's a pair of fairy definitions: Capacitative reactance is the tendency of the free electrons in a conductor to preserve a state of electrical equilibrium, and capacity is simply a means of reducing capacitative reactance.

"The first definition is really too narrow because capacitative reactance actually tends to keep *all matter* in a state of electrical balance — just as gravity tends to keep water in a state of mechanical balance. Since 'all matter' includes nonconductors as well as conductors, a fellow can see how electrical waves can exist in a dielectric — such as air. Of course, actual current-flow can only take place in a conductor where there are free electrons that can skip from atom to atom, but displacement 'currents' can 'flow' quite readily in a dielectric. The idea is that the electrons belonging to an atom, being disturbed, swing out in the electrical breeze and transmit the

how to secure a perfect vacuum in a 'vacuum' tube. Construct a very tall tube — if it isn't tall enough, make it taller — put all three electrodes in the very top of the thing and pump as much air as you can from the bottom. Gravity will now cause the residual air to settle (?) to the bottom, leaving a perfect vacuum at the top!

"Oh! Gasses like to disperse, do they? Then consider this: Some gasses weigh so little that a

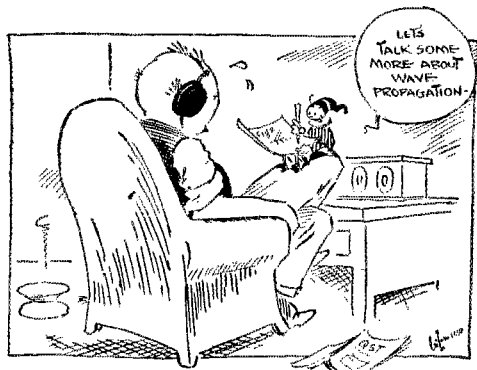

balloon filled with them will lift almost as much weight as the weight of the air it displaces. Suppose we release a quantity of such very light gas. It will rise to the upper limit of the atmosphere — if there is a limit. The farther the gas recedes from the earth the less it will weigh because the gravitational attraction will be lessened by the distance. As it recedes from the earth, the surrounding atmosphere will be less dense and exert less pressure on it. It will, therefore, expand in its effort to fill all the available space. Which will win, the attraction of gravity, or the tendency of gasses to fill every nook and cranny of 'space'? Suit yourself, but don't forget that the very same scientists who claim that interstellar space is a void, insist that 'nature abhors a vacuum!' Yes, 'space' is filled with atmosphere; it's darn thin, but it's there."

Uncle Jimmy wants you little Hams to remember that he is just telling you what Piper said. I'm not saying that it's *true*. Don't try to tell it to big brother, R. E. Ham, because he won't believe it. He doesn't *believe* in fairies.

"Let's talk some more about wave propagation," suggested Piper. "I can see that you're kinda dumb about such things." He fished another piece of paper out of his tiny pocket before I could decide whether or not to get mad. "This is Fig. 2," he said. "It shows how light waves get bent when they pass at an angle from a dense to a thin or a thin to a dense medium. I drew double lines to show that the light beam has dimensions. Now, Uncle Jimmy, do you know *why* the wave changes its direction of travel?"

"I don't remember of anyone ever telling me why."

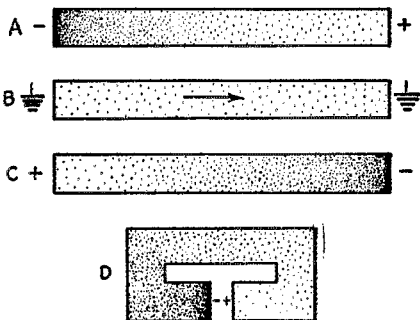

FIG. 1

disturbance to adjacent atoms which, in turn, jar their neighbors and so on and on. Not an electron leaves its atom, but the impulse travels like actual current-flow and is subject to inductive and capacitative reactance."

"Yes," I interrupted, "it's not hard to see how radio waves travel through dielectrics, but how do they cross interstellar space?"

"The men of science drag in the ether theory. Ether is something which is supposed to be nothing and pervades all space. If it pervades space, where is the space? Or, if it is nothing why talk about it?"

Piper changed to an apparently irrelevant subject. "Say, Uncle Jimmy, I'm going to tell you

"No," said Piper, "they usually don't try to tell that part of the story. Well, here's why: Light travels faster in a thin medium than it does in a dense one — faster in air than in glass, for example."

"But the velocity of light is constant!" I protested. "You're wrecking the relationship between wavelength and frequency!"

"Wavelength my eye!" snorted Piper. "That's out. Shut up; and don't interrupt me again." (Fairies are *so* short tempered!) "Look at the picture and you will see that there is an instant

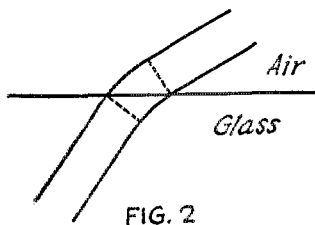

when one side of the beam is in one medium and the other side is in the other. During this instant, one side of the wave travels faster than the other. Naturally, it *turns*.

"Even a slight difference in the density of the mediums will cause refraction of light, as you can prove by noting the distorted appearance of the objects viewed over the top of a hot radiator or stove. The density of our atmosphere decreases with increase in altitude. This difference in density refracts light waves a little. It refracts radio waves to a greater extent because the dimensions of the radio wave are greater than the light wave and one side of the radio wave is in a medium much denser than is the other.

"Oh, sure; the Kennelly-Heaviside layer is there, all right, but I wanted to point out that it isn't the only thing that affects the direction of radio waves. If it were, the Warner Splatter System wouldn't work.

"Well, Uncle Jimmy, I'll have to say '73' and 'CUL' because the rat business is pretty heavy of late and it doesn't leave me much time for DX. I worked Jupiter last night with three ergs input to my pipe."

Piper grasped the antenna and vaulted lightly into space. Something — perhaps the reactance caused by Piper's exit — struck me between the eyes. With the return of consciousness came also the dawning realization that I was seated in the midst of what was once a slop rectifier and holding the new "1929" receiver in my lap. It was almost as if I had dropped asleep and fallen out of my chair, but I knew I hadn't for from the vast dim distance came a laugh — Piper's laugh.

Now, dear little Hams, Uncle Jimmy has told you a nice bed-time story — a fairy tale — and he has told it for a reason. It is quite probable that everything I have said is all nonsense. There is the

possibility, though, that some of it is on a par with Mr. Warner's famous Splatter System, *some* of it *may* be right. (No, no Officer! Mr. Warner is entitled to the first ride in the nice wagon!)

The purpose of the fairy tale is to point out that there are no flanges on the imaginative wheels of a mere Ham. He isn't hampered by the knowledge of So-and-so's Law and of such-and-such an equation that must be satisfied. He can't see the hundred-and-one reasons why his theory must be wrong. The marvelous part of it is that the ham is sometimes right.

A boy once said: "I have a kite. It is heavier than air, yet it flies. Someday I will fly like that!" Learned engineers pointed out to the boy that the scheme was impossible. Their argument ran something like this: If the weight of the kite is doubled, twice as much surface will be needed to support it, *but* if one starts by doubling the surface, he will find that he has increased the weight about four times in order to keep the same proportion of structural strength. A kite, they said, with enough surface to support the weight of a man would be too heavy to lift itself! The engineers deserved to be right. They had given the problem deeper study than had the boy. They were hampered, though, by their own knowledge! We all know that the *boy* was right.

We can depend upon scientists and engineers to develop new territory to the limit after we have discovered it, but the burden of discovery rests upon our shoulders. An eminent engineer cannot risk his reputation by talking about fairies until he has positive proof that fairies exist. I can. You can. We have nothing to lose by being wrong and have everything to gain if we should happen to be right.

Another thing; I know some fellows who have a lot of original "kinks" in their shacks. These fellows don't mean to be stingy with their ideas; they are merely *afraid* to send them in for *fear* QST will turn them down. Gosh! I wish QST would turn down my stuff. Whenever that happens, I will know that the editors have been able to fill QST with material better than mine. That won't be bad luck for anyone! The best of whatever comes in is printed in QST; if that "best" is sometimes pretty poor, it's our fault — *your* fault!

In a recent editorial, Mr. Warner said: "There is a great shortage of QST material." Editor Warner shouldn't have had to say that. QST belongs to us — to the membership of the A.R.R.L. We can't get any more out of our magazine than we put into it. The principal reason for the existence of QST is to provide a place where the members of the A.R.R.L. can swap ideas. Chewing the rag over the air is fine business and I do a lot of it, but when a fellow wants to swap ideas with all of Hamdom, he needs the pages of QST.

Do you think that a fellow fully pays his way to a convention when he planks down the price

of the banquet? He doesn't. The fellow who goes to a convention with the idea of absorbing all the valuable information he can without giving a thing in return from his own store of knowledge isn't quite honest! You may get a copy of *QST* for a quarter — but you can't pay for it in that way. Let's be honest.

There isn't room for all of us to push; some must ride, but we can only discover the best pushers (many of whom are still hidden lights) by everyone trying to push.

I am not trying to set myself up as a shining, unselfish example; this is really written for a selfish reason. It's like this: *QST* is priced at two-bits per copy. I feel that I am only getting about thirty-five cents worth out of it. I am beset with a hunch that we can raise the value (not the price) to four-bits. In other words, I want to double my money on a sure thing!

All this sounds fine, but I have lived long enough to find out that we very seldom, if ever, get something for nothing. I have learned that the statement, "Honesty is the best policy," is a truth. Please note that the statement has nothing to do with morals. Emphasize the word, *policy*. The more willing we are to pay, the more likely we are to get our money's worth. The fellow who thinks he is going to escape payment often pays most heavily in the end.

The two-bits we pay for *QST* couldn't begin to cover the cost of publishing it, but because the advertisers are willing to pay, it isn't a losing

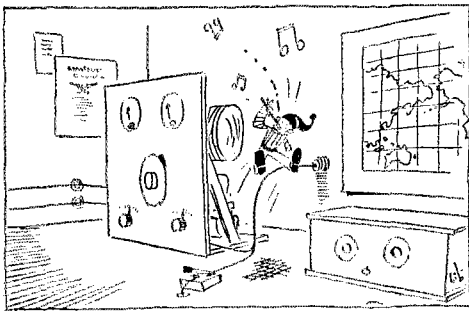

Piper grasped the antenna and vaulted lightly into space

proposition. The advertisers are business men — not moralists — yet they are willing to pay. Why? Because they know that they can't get something for nothing. They want increased sales and they know they will have to pay for it. We, in turn, pay the advertisers. The more we pay them, the more they will advertise. We win. They win.

QST would be on a par with any other two-bit magazine if we only put into it two-bits plus what we pay the advertiser. Here we put our finger on beautiful opportunity. It is the privilege of the members of the A.R.R.L. to raise the value of *QST* to whatever they like by increasing the value of their contributions. Here, again, the fellow who

is most willing to pay reaps the most benefit. A fellow cannot write an article for *QST* without automatically learning more than he does in reading a whole issue-full of the other fellow's stuff. If, for instance, Mr. Warner is wearing a grouch because he cannot find two men to take the place of Ross Hull and turns this yarn down in consequence (articles are always turned down because the editor has a grouch) I, at least, will still be the winner because of what I have been forced to learn in writing it.

My dear little Hams, if you don't like to listen to Uncle Jimmy's fairy tales, don't just tune me out — that would be wasteful — but put me off the air. The way to do that is to get into the uncle business yourselves and out-uncle me. Then everyone will profit, including Uncle Jimmy.

73, little Hams, and sleep tight: the boogers at Washington can't get you if you mind what Mamma and Papa Ham tell you. Nighty-night!

Exit Uncle Jimmy.

Cries are heard from without: "Please, Officer! Get a bigger wagon; I had to stand all the way last time!"

Photo-Electric Cells and Methods of Coupling to Vacuum Tubes

(Continued from page 21)

be used if they are obtainable but it is generally easier, quicker, and cheaper; even counting the additional stages required, to throw together a resistance-capacitance amplifier.

If resistance-capacitance stages are added, make the plate resistor about two or three times the plate impedance and use low plate voltage on the first few stages. The use of this low plate resistance does not give as high amplification as can be obtained with a higher value, but the frequency response and operation is much better and the use of low voltage reduces the so-called microphone noises as well. The reason the frequency response is better is due to the fact that as we decrease the plate resistance, the effective input capacity of the tube is also decreased. Do not go much below twice the plate impedance for the value of the plate resistor, however, as below this value distortion is introduced in the output circuit. Needless to state, the resistance units themselves should be non-inductive.

Fig. 7 shows a circuit with values which will give good response at extremely low frequencies — around 15 and 20 cycles — as well as at the rather high frequencies — around 10 to 12 thousand cycles — and will make an excellent starter for a television amplifier.

Fig. 8 shows a connection using a screen-grid tube for enormous gain in the medium-frequency zone.

Fig. 9 shows a circuit employing a common battery as plate and polarizing-voltage supply; while Fig. 10 shows a similar circuit suitable for relay work and the like.

Facts About Glass Arm

By Walter H. Candler*

THERE are many things which contribute to the weakening of the telegraph operator's arm. Medical authorities are pretty well agreed that the principal cause is a toxic condition of the system culminating from decayed teeth, tonsils or other infected area. These infections, frequently so insignificant they escape notice, poison the blood stream which, in turn, produces inflammation of the nerves and muscles at the weakest point. With the telegrapher, the weakest point usually is his arm.

Now, the question is: "Why is a telegrapher's arm his weakest point?" What about the arms of athletes, laborers and others, skilled and unskilled? Their arms usually become stronger with use. Perhaps Mother Nature failed to make such bounteous provision for the arm of the telegrapher. We are inclined to believe this when we consider that his arm, wrist and fingers become weaker and less responsive with continued use, rather than stronger and faster.

I am inclined to believe that the condition of the telegrapher's arm, diagnosed as vocational neuritis, which usually yields to medical treatment, is one thing, whereas the condition we operators recognize as "glass arm" is another. The symptoms, in many instances, are similar, with one ever-present exception. In true neuritis, there is inflammation; in true glass arm, there is neither inflammation nor soreness. At first, there may be sensitiveness, but this subsides and the arm gradually loses its erstwhile snap and responsiveness. Dot letters are difficult to make correctly with the usual speed. The operator becomes aware that he cannot send the fast, accurate stuff he once did; others with whom he works tell him his sending is "rotten." He tires quickly.

When this condition is caused or helped along by a seepage of pus into the blood stream from some infected area, it is accompanied by pains in the wrist, forearm, neck and back; frequently headaches, irritability and other forms of nervousness. When the condition has been cleared up by the proper medical treatment, these symptoms disappear, but the arm is ever afterward perceptibly weak; the old snap has gone out of it. Hence, you will observe that toxæmia, causing neuritis primarily, contributes, secondarily, to the condition. In other words, its after effects are manifested in "glass arm."

But, there are other causes for "glass arm," the principal ones of which are: Unnatural

position of the arm in telegraphing; this retards normal circulation. Muscle and nerve strain in both writing and sending; long confinement, which lowers residual energy or body tone; undue and prolonged pressure upon the table, especially the corner of the table, with the under part of the arm, and last, but by no means of the least importance, the ever-present negative suggestion that ultimately the arm will fail.

Suggestion is a powerful factor. Young operators hear old ones complaining of the weakened condition of their arms and it is suggested to them that it's "only a matter of time" until they, too, will have "glass arm."

When a weak arm has been neglected over a long period of time, the muscles and nerves become atrophied and may develop telegrapher's paralysis. It has not been so long ago that the seat of all forms of paralysis was found to be in the brain itself; that the paralyzed member was but the result of such condition. This, I believe, is not always applicable to telegrapher's paralysis but, when found so in isolated cases, there even then remains much doubt unless the diagnostician is as familiar with psychology as he is with physiology, and is capable of differentiating between brain symptoms on one hand and mental on the other.

To go into this subject thoroughly would entail an exhaustive discussion of reflexes which limited space forbids. Suffice it to say, however, that every muscular action is in response to a mental reflex. For example: The impulse of dots, dashes and spaces is sent out by the brain. It is a mental process. The hand on the telegraph key, aided by normally functioning muscles and nerves, responds; does what the mind commands; then, by virtue of many repetitions, the conscious mind gradually places its responsibilities onto the sub-conscious mind. Habit is formed. Habit is anything that we can do without conscious thought, like writing rapidly on the typewriter, sending and receiving while actually thinking of something else.

When the sub-conscious mind sends out an impulse for six dots and the hand falters, making four dots space two dots, or five or eight dots, the conscious mind jumps in and endeavors to make the correction. Trouble ensues here which we shall not discuss now. A repetition of this conscious interference causes an unbalancing of the mental and nerve system which interrupts co-ordinative work. The result is that the operator puts forth more effort to make dots and dashes

*6343 South Kedzie Ave., Chicago, Ill.

(Continued on page 33)

Indicating Instruments for Amateur Transmitters

By D. J. Angus*

INDICATING instruments are a necessary part of every radio transmitter. Without them, a transmitter cannot readily be adjusted to secure maximum output, maximum overall efficiency, or the greatest life from the tube equipment.

An understanding of the underlying principles governing the operation of indicating instruments will often enable the user to accomplish a great deal more with his instrument equipment than would otherwise be possible.

All transmitters containing tube equipment worth more than four or five dollars should be provided with a filament voltmeter connected directly across the filament terminals to enable one to operate the tube at the filament voltage recommended by the manufacturer. A relatively small increase in filament voltage shortens the filament life greatly and operating the filament at too low a voltage either results in poor operation of the transmitter or, in the case of oxide coated filaments, is liable to cause the destruction of the filament. When thoriated filaments are run too low, the thorium does not boil out to the surface quickly enough and the tube requires frequent reactivation. This also results in a shorter life than should be obtained.

The plate circuit of each tube or group of tubes making up each unit in a transmitter should be provided with a milliammeter showing the plate current. This not only makes possible holding the plate current to the value specified by the manufacturer but also provides one of the most sensitive indicators of whether the radio frequency circuits immediately connected to the tube are properly tuned.

It is usually desirable, although not absolutely necessary, to provide a radio frequency ammeter in the antenna circuit in order that any changes will immediately be noticed after the set has once been adjusted.

A high-voltage voltmeter to indicate the plate voltage is a handy instrument to have but is usually rather expensive. It serves as a check on the operation of the rectifying equipment or the generator as the case may be.

Other instruments can be installed to secure additional information or to decorate the panel but the above list covers those which most experienced operators have found necessary to secure the best results from their equipment.

Radio instrument equipment divides itself into three general classes; namely, a.c. instruments, d.c. instruments, and radio frequency instruments. The a.c. instruments make use of the moving iron type of movement. The d.c.

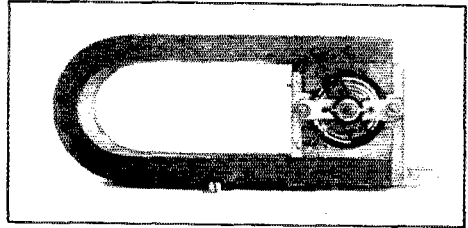

A VIEW OF A D'ARSONVAL MOVEMENT WHICH IS THE BASIS OF PRACTICALLY ALL D.C. INSTRUMENTS

A large U-shaped permanent magnet maintains a constant magnetic field across the space between the pole-pieces and an iron core. The pole pieces and core are accurately machined so that the moving coil which is mounted on pivots can rotate between them. The air gap is reduced to a minimum to allow the field of the permanent magnet to be as strong as possible.

instruments make use of what is known as the D'Arsonval type of movement which employs a permanent magnet. The radio frequency instruments in most cases make use of a D'Arsonval type of movement operated from a thermocouple through which the radio frequency current to be measured is passed. There are a few radio frequency instruments making use of a wire heated by the radio frequency current, the expansion of which is used to move the pointer over the scale.

MOVING IRON INSTRUMENT

Practically all of the a.c. filament voltmeters and ammeters use what is known as the moving iron type of movement. This type of movement depends for its operation on the repulsion between two pieces of iron magnetized to be of like polarity.

Fig. 1 shows in a general way the construction of the moving iron type of movement. One piece of thin iron is stationary and another is mounted on a staff in such a manner that as it recedes from the stationary piece of iron the staff is caused to rotate. The staff also carries a pointer which is moved across the scale by the motion of the moving piece of iron. This motion is opposed by a

* W9CYQ, Esterline-Angus Co., Indianapolis, Ind.

hair spring which resists the tendency of the iron vanes to separate.

Both iron vanes are surrounded by a single coil of wire carrying the current to be measured and magnetizing both vanes, so that they are of the same polarity. In the case of the voltmeter the coil is wound of fine wire and has in series with it a fixed resistor which is adjusted so that when the full scale voltage is applied to the terminals of the instrument the current flowing is just sufficient to cause the pointer to move to the full scale position. Lower values of voltage will cause the pointer to move to intermediate points between zero and full scale depending upon the voltage across the instrument terminals.

The ammeter coil is wound with coarse wire and carries the current to be measured. Calibration is effected by changing the relative position of the coils and the vane and in some cases by an adjustable resistor connected across the terminals of the coil.

The moving iron instrument can be used on d.c. with sufficient accuracy for most uses around a transmitter. The instrument will read slightly different, depending on the direction in which the current passes through it, but an average of the two readings secured by reversing the connec-

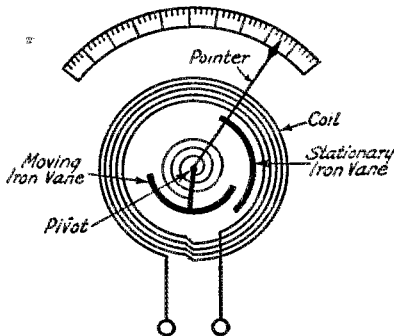

FIG. 1.—THE INTERNAL PARTS OF A "MOVING IRON" INSTRUMENT ARE INDICATED ABOVE

The coil which surrounds the iron pieces magnetizes them to the same polarity and causes them to be mutually repellant. As one piece is fixed in position, the other which carries the pointer is caused to rotate away from it against the action of the coil spring. Its final position depends upon a balance between the force of the spring and the magnetic field. Regardless of the direction of the lines of force of the magnetic field, the two pieces will always be of the same magnetic polarity and the instrument will, therefore, be suitable for either d.c. or a.c.

tions to the instrument terminals represents the actual value of d.c. passed through the instrument. This difference is usually so small that it is of no material importance in a transmitter.

The torque produced by a hair spring when turned through a given angle, is proportional to that angle. The repulsion force between the iron vanes in the moving iron instrument increases at a higher rate than the current through

the magnetizing coil, and in some instruments may increase nearly as the square of the current being measured. Therefore moving iron instruments have a scale which is closely spaced near the bottom and much more open near the upper

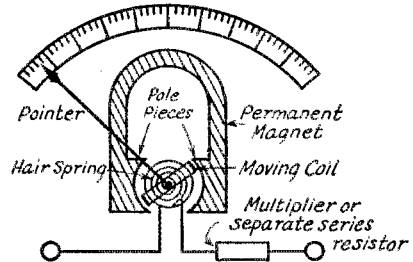

FIG. 2.—THE GENERAL SCHEMATIC ARRANGEMENT OF A D'ARSONVAL VOLTMETER IS SHOWN ABOVE

In addition to the basic moving coil assembly, there is a resistor connected in series with the coil winding. This resistor is called the multiplier and the range of the meter will be dependent upon its value. Its resistance is usually quite high and in high-voltage meters it is mounted in a separate box and must be connected in series with the meter when it is put in service.

end. When instruments of this type are being purchased care should be taken that their range is such that the values to be measured come in the open part of the scale rather than near the lower end where the instrument is difficult to read.

D'ARSONVAL INSTRUMENTS

Practically all of the d.c. voltmeters, milliammeters, and ammeters used around a radio transmitter operate on the D'Arsonval principle. An example of the D'Arsonval type of movement is illustrated in the first photo.

The D'Arsonval movement depends for its operation on the force causing a conductor carrying current to travel across a magnetic field in which it is placed. The movement, as may be seen in the second photo, consists of a square coil of wire carried by a pair of pivots so located that the coil is free to turn in the magnetic field between the poles of a permanent magnet. The coil carries a pointer moving across the instrument scale, and a pair of hair springs which restrains its movement and returns the pointer to zero when no current is flowing through the coil.

Current passing through the pivoted coil causes it to tend to rotate, rotation being opposed by the hair springs. The torque produced by the current is proportional to the current flowing through the coil while the counter torque produced by the hair springs is proportional to the angle through which the coil is turned. Therefore the angular displacement of the coil is proportional to the amount of current flowing through the coil and the pointer will move a distance proportional to the current or voltage being

measured. The instrument will, therefore, have an evenly divided scale.

Current is led into the moving coil through the same hair springs that are used to control the position of the pointer. A stationary block of iron is mounted inside of the moving coil in order to cut down the reluctance of the magnetic circuit and enable a relatively small magnet to produce the necessary flux. This iron is so shaped that the field strength in the air gap through which the coil moves is uniform, insuring that the instrument will have a uniform scale.

D'Arsonval voltmeters as shown in Fig. 2 have a high resistance connected in series with the moving coil. Its value is adjusted so that at full scale voltage an amount of current flows that will just bring the pointer to the full scale position. At any intermediate voltage, the pointer will take up a corresponding position.

Instruments of this type require between 5 and 20 milliamperes, usually averaging around 15 milliamperes, for full scale deflection of the pointer.

When the full scale voltage is 150 volts or lower the series resistor is usually placed inside

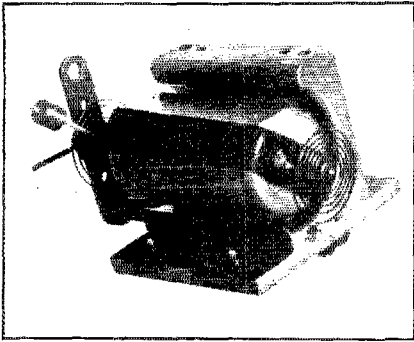

A MORE DETAILED VIEW OF THE MOVING COIL, POLE-PIECE, HAIR-SPRING AND IRON CORE MAY BE SEEN HERE

The permanent magnet and one pole-piece have been removed. The iron core is fastened to the plate of non-magnetic material to which the pole-piece is mounted and is located in such a position as not to interfere with the motion of the coil over the useful range of rotation. At the center of the hair spring may be seen the pivot upon which the coil rotates. At the left end of the coil may be seen a short rod with a weight mounted upon it. This is to counterbalance the weight of the pointer and make the position of the pointer independent of the angle at which the meter is held.

the instrument case or mounted directly on its back. Where the voltage exceeds this value it is usual practice to supply a separate resistance box which must be connected in series with the instrument. Generally speaking, it is not good practice to dissipate more than $1\frac{1}{2}$ watts inside of the case of an instrument because of the resultant heating effect. This limitation prevents placing the series resistor of the higher voltage meters inside the case.

The D'Arsonval d.c. ammeter and milliammeter is illustrated in Fig. 3. This type of instrument contains a relatively low resistance strip, or shunt, through which the current to be measured is passed. The terminals or the moving coil are connected across this resistor, so that the voltage drop caused by the current passing through this resistor is applied to the moving coil. It is obvious that the ammeter is essentially a voltmeter, having a very low range, and measuring the voltage drop across a resistor carrying the current to be measured.

The only difference between an ammeter and a milliammeter is in the size of the shunt employed. The movements are usually designed to come to full scale at between 50 and 100 millivolts.

RADIO FREQUENCY INSTRUMENTS

All instruments for measuring radio frequency current depend for their operation on the heating effects of the radio frequency current being measured.

The thermal expansion instrument contains a fine wire through which the current is passed. The expansion of the wire due to its heating is measured by a pointer, the position of which is controlled by the length of the wire. This type of instrument is relatively slow in its operation and has been largely superseded by instruments operating on the thermal-electric principle.

When two dissimilar metals are joined together and the junction heated, a voltage is generated which is proportional to the difference in temperature between the heated junction and the other ends of the wires. Figs. 4 and 5 show two methods of using this principle in connection with a D'Arsonval movement to measure radio frequency current.

The construction shown in Fig. 4 is employed where the amount of current to be measured is relatively small, usually not to exceed one half ampere. Two small wires of dissimilar metals are electrically welded together at the center. The radio frequency current to be measured passes in through one wire and out through the other, heating the wires and the junction. The remaining ends of the wires are connected through a calibrating resistor to the terminals of the moving coil of the instrument. The heating effect of the radio frequency current passing through the dissimilar wires causes a direct current voltage to be generated, which in turn results in a flow of direct current through the instrument moving coil circuit as shown in the illustration.

The heating effect is proportional to the square of the radio frequency current being measured whereas the voltage generated across the junction is proportional to the temperature. Therefore, the motion of the pointer over the scale will increase approximately proportionally to the square of the radio frequency current passed

through the thermo-couple. Because of these factors the instrument has a scale which is crowded at the lower end and open at the upper end. This makes it necessary to purchase instruments of such a capacity that the average current to be measured will be in the open part of the scale. Radio frequency ammeters of this type are not especially accurate below a quarter of the full scale capacity because the divisions are crowded at the lower ends.

Where the radio frequency current to be measured exceeds approximately one half ampere, it is customary to use two dissimilar wires connected in parallel as far as the radio frequency is concerned, but connected in series as far as the thermal-electric effect is concerned. This system of connections is shown in Fig. 5. It will be noted that the voltage produced at the junction "A" is in the same direction as the voltage produced by junction "B" and they are in series so far as the d.c. path is concerned. This results in not only a higher thermal-electric voltage but also much greater current carrying capacity.

Most thermo-couple instruments are designed for a d.c. voltage across the moving coil at full scale of between 15 and 25 millivolts. In all cases they are calibrated by adjusting a small calibrating resistor connected in series with the moving coil.

GENERAL

It is rare for one to have trouble with the moving iron type of instrument since the forces on the parts are relatively light, and there are no

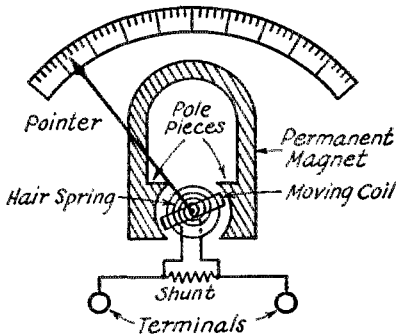

FIG. 5.—THIS SHOWS THE METHOD BY WHICH THE D'ARSONVAL MOVEMENT IS APPLIED TO THE MEASUREMENT OF CURRENT

A piece of resistance wire is connected across the terminals of the moving coil and the current to be measured passes through it. The voltage drop across the shunt is applied to the moving coil and causes a flow of current through it with its resultant movement of the coil assembly and pointer.

moving conductors. In addition to this the moving iron instruments are not so likely to be abused since they are usually employed as filament voltmeters and it is rare that sufficient voltage is applied to the filament circuit to damage the instrument.

D'Arsonval voltmeters sometimes cause trouble due to open circuits in the multiplier or series resistor. These resistors are wound of the finest resistance wire to be had and are easily damaged by mechanical abuse or by allowing the multiplier to get wet. If the multiplier is made up of sections, the open section can usually be found and bridged without the necessity of sending the instrument back to the manufacturer. Tests for open circuits should be made with a 6-volt bat-

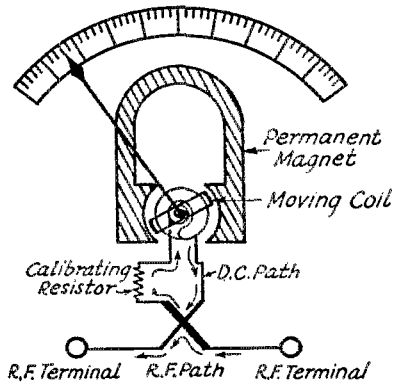

FIG. 4.—WHEN THE AMOUNT OF RADIO FREQUENCY CURRENT TO BE MEASURED IS SMALL, A SINGLE THERMO-COUPLE IS EMPLOYED

The radio frequency currents pass through the junction of the two dissimilar metals and generate heat which in turn generates a small d.c. potential across the junction. This d.c. passes through the D'Arsonval movement and actuates the moving coil to which the pointer is attached. A resistor in series with the moving coil allows the meter to be calibrated without necessitating adjustment of the thermo-couple or moving coil.

tery connected in series with a telephone receiver. Any other method of testing is liable to result in a current through the moving coil sufficient to damage the instrument. Also the resistance of the series multiplier is usually so high that opens can only be found by means of a relatively sensitive test circuit.

Milliammeters are often damaged by the user by accidentally connecting them across a low voltage source that has insufficient resistance to limit the current to a value below that which will burn out the milliammeter. An ordinary dry cell will destroy a milliammeter or millivoltmeter almost instantly. The damage done may consist of simply bending the pointer but more often consists of tangling or burning off the hair springs, overheating the moving coil, or damaging the pivots.

A bent pointer can be straightened by holding the pointer near the pivot attachment with one pair of tweezers, and straightening it with another pair. Do not try to hold only the moving coil when bending the pointer as this will, in many cases, loosen the attachment between the pointer and the coil system.

Tangled hair springs can usually be straightened by the use of tweezers. If the springs have been overheated, it will be necessary to install new ones. This can best be done by the manufacturer, since he has springs in stock that have

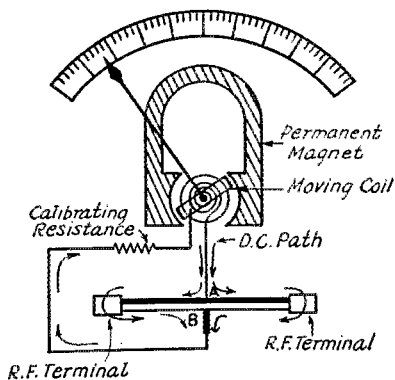

FIG. 5.—FOR HIGHER CURRENTS THE SIMPLE TYPE OF COUPLE IS NOT USED

In this case, the radio frequency current flows through two wires or strips in parallel. In the drawing, the heavy line represents one type of metal and the thin line another. The junctions at which the d.c. is generated are at the middle of the wires and are labeled A and B. As far as the moving coil system is concerned, these are in series and the voltages generated aid each other because they are of the correct polarity. As in Fig. 4, a calibration resistor is provided.

the proper characteristics, and also has the special tools used in assembling the springs on the moving coil.

If the user has occasion to install his own hair springs, he will find that the best soldering iron to use is one made up of a piece of No. 8 copper wire sharpened to a fairly fine point. The tweezers used in holding the hair spring can be made by taking an ordinary pair of tweezers and grinding them to a fine point. When soldering the hair spring in place, do not heat the body of the spring, but only the ends where the attachment is to be made. Use rosin, or some other non-corrosive soldering paste as a flux.

The usual difficulty encountered with thermo-couple radio frequency instruments is that of burning up the thermo-couples by current overload. This seldom results in any damage being done to the movement and the trouble can be corrected simply by replacing the damaged thermo-couple with a new one. Most manufacturers of instruments of this type will sell the thermo-couples separately so that the customer can make his own replacements.

When replacing the thermo-couples, it will usually be necessary to adjust the resistor connected in series with the moving coil in order to bring the instrument to calibration. Calibration can be made with 60-cycle current as the reading of the instrument is the same on radio frequencies as it is at 60 cycles.

The capacity of thermo-couple instruments can be changed by soldering a shunt made of a short piece of copper wire across the thermo-couple lugs. If it is necessary to double the capacity of the instrument, the instrument should be brought to full scale by means of 60-cycle a.c. A shunt should then be soldered between the brass block carrying the thermo-couples, and adjusted so that the instrument reads one half the full scale value. The current passing through the instrument then will be represented by the reading of the instrument multiplied by 2.

Shunts on radio frequency instruments always should be as short as possible, and placed parallel and close to the thermo-couple. If they are placed outside the instrument case, the instrument will not read exactly the same on radio frequencies as it does on 60 cycles.

Do not attempt to increase the capacity of a radio frequency ammeter to any extent by increasing the resistance in series with the moving coil since this simply results in overloading the thermo-couple and probably will lead to its ultimate destruction.

A milliammeter can be used as a voltmeter by using it to measure the current caused to flow through a known resistance by the voltage to be measured. For instance, a 100-milliamperere milliammeter can be used as a 1000-volt voltmeter by connecting in series with the instrument a fixed resistance of 10,000 ohms. The instrument would draw 100 milliamperes at full scale which would be an objection if it were to be left continuously in the circuit but will serve for short tests.

The range of any of the voltmeters can be changed simply by changing the resistance of the series multiplier. The full scale capacity of a voltmeter is proportional to the total resistance of the multiplier and movement. Therefore if one desires to double the capacity of a voltmeter it is only necessary to double the total resistance, which means connecting in series with the instrument another resistor equal to that of the instrument and multiplier.

For most radio work, the enameled resistors used as grid leaks make satisfactory series resistors for increasing the range of voltmeters or for measuring voltage by means of milliammeters. These resistors will dissipate anywhere from 30 to 100 watts, depending on the size. If necessary, two or more can be connected in series for the higher ranges.

Stickiness of an instrument pointer or sluggishness in reaching either zero or the value to be measured, is caused by dirt in the space in which the coil or moving vane rotates or is due to dull or broken pivots. The dirt can be removed by blowing through the air gap or by means of a small piece of paper. The pivots can be sharpened by whetting them with a small piece of Arkansas oilstone. However, it is usually best to send the

instruments back to the manufacturer in case the pivots are damaged.

Generally speaking, the instrument used in radio transmitters gives less trouble and more real service than any other part of the equipment. They are cheap enough so one doesn't have to make them himself and a little money invested in good instruments always pays.

Facts About Glass Arm

(Continued from page 28)

correctly. This is a strain, and the "upset" or "nervous" operator soon is working against himself, like one trying to swim up a swift stream.

While telegraphing, the arm is in an unnatural position. The blood cannot circulate freely to the extremities as if it were being used in swinging motion. Pressure on the table not only retards circulation but interferes with nerve functioning. The muscle and nerve tissues become impoverished and their vigor and elasticity diminish. Capillary circulation becomes weak and in advanced cases ceases altogether. The hand usually is cold, clammy, and while there may be no pain to speak of, the victim is aware of an uncomfortable feeling from the tips of his fingers to his elbows.

Now, the question of a remedy arises. Will exercises help?

If the condition is true neuritis, and only a capable physician can determine this, exercises of any kind will do more harm than good. Exercises should not be taken until the cause has been cleared up; then, certain exercises will help to build and develop the small muscles of the arm which in time, if followed properly under the direction of a physician or one who understands the condition, will restore it to its normal state where it will respond readily to the mental impulse. It must be understood, however, that just any kind of exercise will likely do more harm than good. As with medicine so with exercise: "What will cure one will kill another."

I have had occasion to interview many celebrated musicians, artists, and others doing work that necessitated the free, easy action of their hands, arms and fingers. In every instance I found that the "right kind" of exercise constituted part of their daily routine.

How necessary, then, are corrective exercises for developing the telegrapher's arm? He needs certain exercises to promote free circulation to his finger tips, to rebuild broken down cell tissues and carry off the dead cells. He needs other forms of special exercises to develop the small muscles as they should be developed in a telegrapher's arm — not like those of a blacksmith, laborer or strong man — to promote uniformity, rhythm, normality, speed, and accuracy.

A muscle-bound arm cannot send on a telegraph key. Many cases of so-called cramps of various forms verging on paralysis in some instances, are muscle-bound conditions brought on by the wrong kind of exercises. I say positively, and any physician will bear me out, that indiscriminate exercising frequently does irreparable harm. The antiquated methods of certain well-advertised physical culturists may give a telegrapher large, beefy arms that are useless for sending or writing.

The wrestler and boxer need different systems of exercises. The ball player, sprinter, distance swimmer, walker and tennis player — all, must take specific exercises to develop certain muscles in the right proportion to meet their requirements in muscular control and reflex coordination necessary to skill and perfection. The champion wrestler of the world would be helpless in the prize ring with a Jack Dempsey. He has great, bulging muscles, it is true, but they have been trained to pull, tug, twist and hug — not to strike a blow; and what would Dempsey do in a tennis court pitted against a Tilden or Wills? He could hit the ball with greater force than either, but they soon would easily defeat him because their muscles have been not only properly developed, but trained to coordinate in playing the game. Their minds, muscles and nerves function together.

That the mind and its proper functioning plays the most important part in telegraphing, no one can question; hence it is quite obvious that many cases of glass arm can be traced to improper methods and a lack of mental and muscular coordination.

At another time I shall discuss this phase of the subject and pass along the benefits of my experience in handling many thousands of cases during the past eighteen years.



Re: An Improved Super-Heterodyne

By J. M. Grigg*

THE article, "An Improved Super-Heterodyne," which appeared in the December issue of *QST* described a circuit in which a flaw has since come to light. In this discovery it was revealed that the circuit as shown is not satisfactory if separate tuning controls are used. The reason is that the loop circuit, in series with the grid coil, offers

of frequencies cannot occur, and there is all the utility and flexibility of a separate oscillator. Separate tuning controls may be used, this in the average case amounting to a requirement as single control for a high-beat super is a feat of engineering.

The only change in the oscillator coupler is the addition of a 30-turn pick-up coil inside the

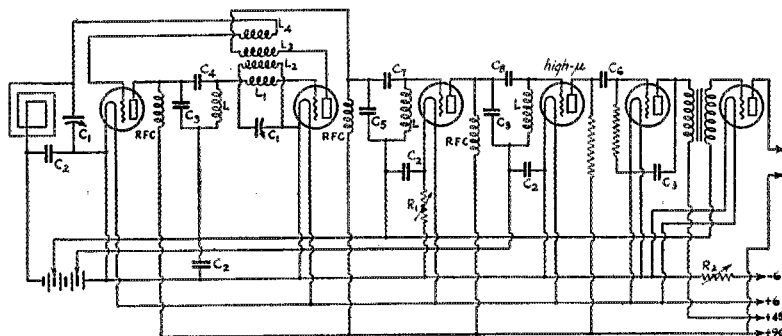

FIG. 1. — THE REVISED CIRCUIT

The first detector no longer is the oscillator but that function has been transferred to the first intermediate frequency amplifier tube. The third and fourth tubes are adjusted as detectors and no means is provided for regeneration. The constants are:

- C1 — 350 μ fd. variable.
- C2 — 5,000 μ fd. fixed.
- C3 — 2,000 μ fd. fixed.
- C4 — 1,000 μ fd. fixed.
- C5 — 1,500 μ fd. fixed.
- C6 — 250 μ fd. fixed.
- C7 — Approximately 1,250 μ fd. This circuit must tune to the same frequency as does L, C3, C4.
- C8 — Approximately 1,000 μ fd. This circuit also must resonate with L, C3, C4.
- L — 63 turns of No. 24 d.c.c. wire on a 3-inch form or a 75-turn bifilar coil may be employed.
- L1, L2, L3 and L4 are specified in Fig. 2.
- R1 — 25 ohms. Used as volume control.
- R2 — 3 ohms.

enough impedance to stop oscillation if it gets into resonance with the oscillator circuit, thus causing an objectionable click.

In the arrangement shown herewith (Fig. 1) the difficulty has been nicely overcome with the elimination, as well, of whatever disadvantage might accrue from stray coupling between tuned circuits. A circuit of this nature, only less elaborate in form, did satisfactory service in low-frequency supers over an extended period; in the application to high frequency amplifiers, however, there is one pitfall that must be pointed out. If lower-beat tuning is used, the oscillations will foul with the amplifier frequency at one point but this, of course, must happen even with a separate oscillator. For the case in mind where the intermediate frequency amounts to several hundred kilocycles and upper-beat tuning to escape interference is the intention, this fouling

tubing, with no change of grid biasing or plate voltages. Excepting for the connecting in of the pick-up coil, the only change in wiring is the transfer of the plate and grid coils to the second tube circuits. The seat of oscillations goes with the transfer but the additional load on the biased tube is insufficient to cause distortion or voltage loss. Grid rectification may be used if desired but no doubt, the loss in selectivity will offset the gain in signal strength.

Another change in the original circuit is the substitution of an additional rectifier tube in the place of regeneration, an arrangement that has also been proved in other circuits. Used in this manner, the additional tube gives the equivalent or better, of another stage of amplification. Although a 201-A will serve as a makeshift, a high-mu tube is preferred, owing to the required resistance coupling. For the resistors, ordinary grid leaks suffice very well. Plenty of high-quality

* 5951 S. Tripp Ave., Chicago, Ill.

energy will be passed before overloading occurs, nevertheless, overloading occurs on ordinary

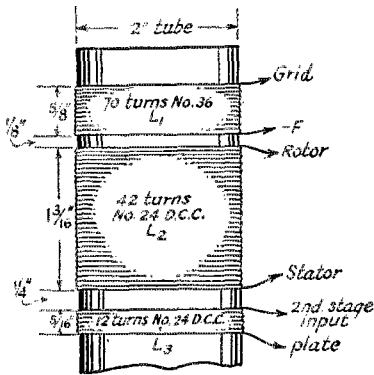

FIG. 2. — THE DIMENSIONS OF THE OSCILLATOR COUPLER

L2 is not shown because it consists of 30 turns inside the tube near L3. All windings are in the same direction.

strong signals; for this reason a volume control ahead of the detector is imperative.

A New Monitor

AN outstanding contribution of radio manufacturers to 1929 amateur station equipment is the new Aero monitor. Its design and construction show a thorough understanding of the requirements to be met not only as to operation but also as to mechanical features and "dress."

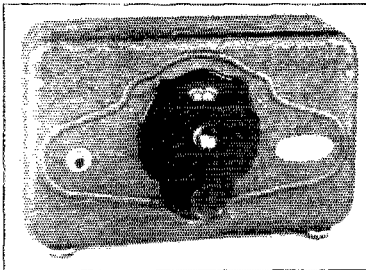

FRONT VIEW OF THE MONITOR

The filament control phone jack is to the left of the dial.

The monitor is a completely shielded unit, the metal case being finished in crystal black. Both "A" and "B" batteries are contained within the case, the "B" battery being of the small 22½-volt size while the "A" battery is a two cell affair of the large flashlight type. Both batteries are clamped in place and are removable. Access to the inside of the shield is gained by removing the back plate which is held in place by three nuts.

A '09 type tube is used, the switch for its fila-

ment supply being incorporated in the filament control phone jack. Inductances of the tube-base type are provided for the 3500-, 7000- and 14,000-kc. bands. Adequate coverage of the three bands is obtained and the circuit is such that smooth oscillation without squealing is obtained over the full frequency range of each coil.

In operation under usual station conditions a QSA5 signal is obtainable when monitoring the signal emitted by the transmitter. The device is

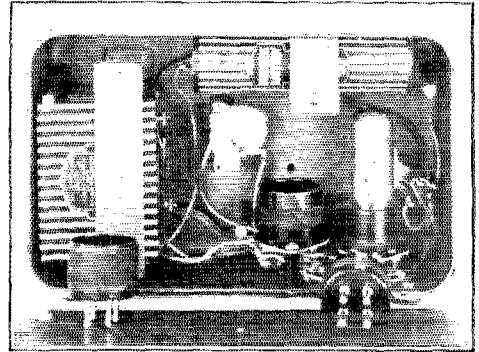

REAR VIEW WITH THE BACK COVER-PLATE REMOVED

also applicable to frequency checking as a calibrated oscillator or as an oscillator in conjunction with a frequency meter as described in the article "The Frequency Measurement Problem," October, 1928, QST.

—J. J. L.

Atlantic Division Convention

June 21st and 22nd at Philadelphia, Pa.

THE Third Annual Atlantic Division Convention will be held in Philadelphia, Pa., June 21st and 22nd, under the auspices of the Philadelphia Radio Association. The Hotel Walton, centrally located, has been chosen for the convention activities. It is the intention of the convention committee to make the convention days sparkle with originality and new ideas, but the age-old traditions of ham conventions will be carried out also, with technical talks, trips, stunts, etc., that will amaze and delight even the dyed-in-the-wool delegate.

The reception committee will be ready and anxious to serve every one and see that those who come are housed properly according to the size of their pocketbook.

The convention tickets will be \$5.00 each. Earl McCullough, Financial Secretary, 36 No. 56th St., Philadelphia, Pa., will appreciate hearing from those who intend to be present.

WSBQ

This is the second published entry in the Station Description Contest detailed in the March issue of QST. The station description considered the best of those on hand will be published in each succeeding issue during 1929. — EDITOR.

THE ancestor of WSBQ, owned and operated by H. M. Walleze at 997 North James St., Hazleton, Pa., was born back in 1912. The bug had stung hard and a "two-bit" galena detector and two-slide tuner got NAA — when the galena was in the mood. A motor-boat ignition coil was salvaged, after several hours' diving, from the bottom of the Erie Canal where its owner had been seen to accidentally drop it one day. Thus the first

meters are as follows: 3-ampere oscillator tank radio frequency ammeter; 100-milliamperere oscillator plate current milliammeter; 300-milliamperere amplifier plate current milliammeter, and 3-ampere antenna current ammeter. Also from right to left, the Marco dials control the variable condensers as follows: Oscillator tank; neutralizing; amplifier tank, and antenna series. The 5-ma. Weston milliammeter at the lower right is used with an Electrad 75-watt, 100,000-ohm resistor in series

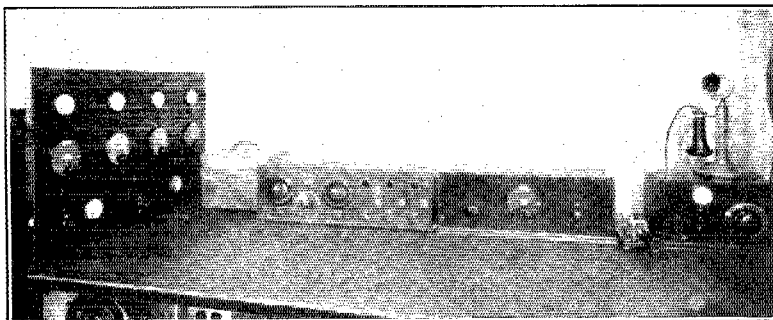

THE NEAT AND CONVENIENT ARRANGEMENT OF STATION EQUIPMENT

The transmitter is at the extreme left. Next in order are the frequency meter in its case, the low frequency receiver, high frequency traffic tuner, Vibroplex and monitor. The generator field rheostat and switch are at the lower left.

transmitter was obtained. It finally grew to a husky 1-kw. spark whose near-synk note was widely known. So much for the "apple-sauce age," gone but not forgotten.

The spark was dethroned by a 5 watt in 1922. Stocks gradually went up to a 250-watt bottle and then settled back to the present 50 watt, crystal controlled.

THE TRANSMITTER

The transmitter proper is completely contained in one unit and was built with the idea of semi-portability; not that there is any desire to carry it around but in event of a move, a 5-ton Mack is not called for. All of the important controls, or rather those most used, are on the panel where they may be easily reached without danger of a "ram." The panel is of bakelite, 30 inches long by 20 inches high and the over-all depth of the transmitter is 14 inches. A glass enclosure is normally in place to keep out dust.

Referring to the photograph of the transmitter, from right to left the Weston type 301 and 425

to make up a 500-volt d.c. voltmeter for the oscillator plate supply. The knob to its right controls a Bradleyleak type E-210, 0-30,000 ohms, used for fine adjustment of oscillator plate voltage.

Directly above the 500-volt meter is the knob controlling the crystal selector switch to be explained later. The cam switch in the center is used to throw the Weston 15-volt a.c. meter, on the left, to either the 10-volt or 7.5-volt filament circuit. The knob to the left of this meter is that of the Bradleystat in the primary of the filament transformer and is used for fine adjustment of filament voltage. Directly above the cam switch is the knob of the Bradleyohm E (taken from a B substitute) used for obtaining grid bias for the amplifier. Theoretically this may be a poor method of obtaining bias but, considering all things, in practice it is very much superior to batteries, especially where variations are in steps of $22\frac{1}{2}$ volts per block.

Referring to the rear view of the transmitter, the equipment immediately identifies itself but

just a few points may be pointed out and explained. The oscillator equipment is seen at the left. The knob back of the tube is that of a receiving type Bradleyleak used to obtain grid bias for the oscillator tube. One crystal mounting has been removed to show its two mounting jacks to the left of the mounting which is in place. The



THE FREQUENCY METER WITH ITS COVER REMOVED

amplifier plate radio frequency choke is next to the National tank condenser while the large fixed condenser to the left of the R.E.L. inductance is the amplifier by-pass condenser. Someone may throw up his hands in horror at the placement of the tank condenser, by-pass condenser and tube with relation to the field of the amplifier inductance and at the lack of shielding in such close quarters. Actually, quite a little study and experiment was given to placing the inductance where it is and no ill effects have been noticed, the losses in this case being insignificant. Not the slightest difficulty is encountered in neutralizing the amplifier or is had from feed-back.

The shelf is of bakelite, 29 inches long by 8 inches wide and is mounted $2\frac{1}{2}$ inches back of the panel. The switch for cutting out the neutralizing condenser when doubling frequency is just to the left of the 50 watt. The pancake antenna coupling coil is mounted on a brass rod so that coupling may be easily and correctly adjusted.

Practically everything on the base-board is easily identified. The filament heating transformer is home-made and huskily built. Three secondary windings have been provided, two 7.5 volt and one 10 volt. One of the 7.5-volt windings is not in use. By looking closely it can be seen that the Electrad resistor used as a multiplier on the 500-volt meter is mounted directly under the big Ward-Leonard resistor on the left by means of a rod through the lower part of the original Ward-Leonard mounting. Above this, on the under side of the shelf, is the Faradon amplifier feed condenser and to the left of that the oscillator plate radio-frequency choke. It is noticeable that the two chokes to be seen are a

little unusual in appearance and they will therefore be explained in detail — for they are unusual.

It is common knowledge that radio frequency has little love for resistance. Since we want to keep the radio frequency current out of the grid return and high voltage source, a simple way to do this is to introduce some resistance in wire form. Therefore, a hard rubber rod of 1-inch diameter was cut in $\frac{5}{8}$ -inch lengths and two 1-16-inch slots were cut in each length, the slots being $\frac{1}{8}$ inch apart. One slot was wound full of No. 28 s.s.c. resistance wire and the other full of No. 28 s.s.c. copper wire, both windings being in the same direction and connected in series. There are approximately 200 turns in each slot. As connected in circuit, the resistance wire goes to the grid when the choke is used in the grid circuit and to the inductance when used in the plate circuit, the copper wire winding being at the low potential radio frequency end. These proved very much superior to other chokes tried (with the possible exception of tuned chokes which are more or less fussy) and are so universally satisfactory that there is no need to use plug-in chokes for the various bands.

The idea of not using a grid choke in the crystal oscillator grid circuit has been found to be very poor practice. A choke is just as essential there as in any other grid circuit. However, be sure that its natural frequency falls well below that of the crystal. An extra large number of turns is preferable to too few or none at all! Immediately in front of the filament transformer can be seen one of the two chokes used in the keying system.

The crystal selector switch is simply a s.p.d.t. switch connected as shown in the circuit diagram and permits the use of either one of the two crystals plugged in while the plug-in mountings permit the use of any two of the crystals available to make up the combination. For ease in wave shifting, a chart with all the adjustments for each of the various frequencies thereon is posted near the set and each crystal mounting is plainly stamped with its individual frequency. This makes a very simple and effective set-up and allows a positive and rapid frequency shift. An average of 30 seconds is required for a change to any one of the available frequencies. All crystals could be mounted and connected to additional switch points but this was not considered necessary. The commotion is just about as bad on one frequency as another anyway!

The shiny bus wiring is of No. 10 hard drawn solid tinned copper. There is no gain in using High-C combinations in a crystal controlled rig. In fact, the tank tuning condensers could just as well be eliminated except for ease of tuning. For this reason there is no call for heavier bus and the No. 10 is rigid and easy to work. All low-tension wiring is run through grounded copper tubing. The core of the filament heating transformer is also grounded.

Operation is about as usual for crystal controlled transmitters of this type with the possible exception of the oscillator. Instead of sweating the crystal with 450 volts on the plate of the oscillator tube and then running the amplifier excitation tap down below the plate end to obtain the correct excitation, this tap is taken right off the plate end of the oscillator inductance and the plate voltage on the oscillator tube is reduced until correct excitation is obtained. The safety factor is greater with this method of obtaining amplifier excitation control, the efficiency of the oscillator is increased and overall operation compares favorably with that obtained with the "tapping" method.

MONITOR AND POWER CONTROL

At the extreme right of the station photograph is the monitor — with the house telephone aboard it. The monitor is in reality more than just a monitor for incorporated within the same cabinet is the transmitter power control. The National V. V. dial belongs to the monitoring end which is a simple oscillating detector of the type of the many recently described in *QST*. The Weston type 354 8-volt d.c. meter is on the station storage battery. Throwing the cam switch up cuts this meter in for readings. Throwing the same switch down lights the filament of the monitor tube, energizes the starting relay which in turn puts the filament and plate supply of the transmitter into action, and lights the pilot light. Thus the monitor is always in action while transmitting and is made exceptionally effective by the ingenious method of coupling its output to the same headsets as are used on the receiver. Details of the coupling arrangement are given in the Experimenters' Section of *QST*, February and March, 1929.

Next to the monitor in the photograph is the "bug," equipped with proper weights to hold it down to 30 words per minute at top speed and capable of working smoothly at 5 words per minute if necessary. The "bug" keys a relay connected in the center-tap of the filament transformer of the power amplifier, both the relay and key being equipped with condensers and resistors in series to prevent sparking and resultant clicks.

FREQUENCY METER AND RECEIVERS

The frequency meter is so constructed that it covers the 14,000-ke., 7000-ke. and 3500-ke. bands, respectively. It was originally built some time back in the days of wave-meters and it is perhaps not exactly correct to refer to it as a frequency meter, although it serves its purpose just as well. The three-point switch serves to vary the inductance to give proper coverage of each of the three bands. No good reason was seen for using a trunk full of plug-in coils and the tapped in-

ductance method has been entirely satisfactory for its intended use. A Jewell current-squared galvanometer serves as a resonance indicator and the dial is calibrated directly in meters from a General Radio 224L Precision Wavemeter. Calibration is checked against the Precision meter at frequent intervals and has held very well so far.

The high-frequency receiver is modeled after the Westman traffic tuner, the L/C ratio being so proportioned that each coil just covers its amateur band. The cam switch on the panel puts the receiver into operation in the down position while in the up position it starts the transmitter and monitor in case break-in is not being used.

A feature of the coils is the use of tickler windings of few turns, large diameter and closely coupled to the secondary windings. The regeneration control does not effect tuning. A 112-A tube is used as a detector with a large grid condenser (approximately .001 μ fd.) since, within reason, the larger the better, for signal strength. No sound reason was seen for using a condenser of

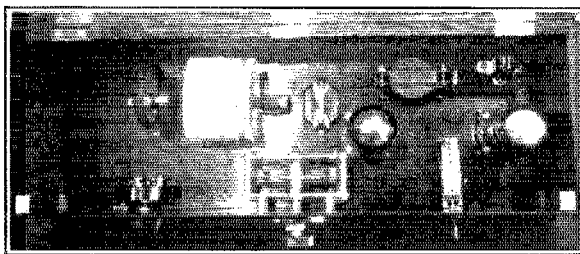

A PEEK INTO THE HIGH FREQUENCY TRAFFIC TUNER

.0000001 μ fd.! The large condenser may broaden the tuning a bit — but very little if the rest of the circuit is correctly designed. This station being primarily a relay station, no necessity has been found for r.f. amplification.

The low-frequency (or long wave, if you will) receiver is a Grebe CR-9 covering from 150 to 3000 meters and is used for recreation on commercial waves. Many interesting things still happen "up" there and a big kick may be had cruising around on these bands and occasionally hearing an old friend of days at sea. When the R.C. stations flop for an SOS, a dash is made for the Grebe which proceeds to work overtime on such occasions.

A Jones cable permits quick change of the common A- and B-supply to either receiver. The A-supply consists of an Exide 200-a.h. storage battery with trickle charger and the B-supply of a homemade eliminator. Where the idea that a B-substitute was N.G. as plate supply for a high-frequency receiver originated does not matter — this one works. A 100-volt Edison B storage battery is kept fully charged as a precaution against a.c. failure, but this is rarely needed.

POWER SUPPLY AND ANTENNAS

The plate power supply consists of a 1000-volt, 250-watt, 3600-r.p.m. Westinghouse generator directly connected to the motor energized from the 120-volt a.c. line and a modified Thor-

power to the latter may be supplied from the generator through a Ward-Leonard 20,000-ohm resistor, the change being made by simply throwing the switch provided for the purpose.

The motor-generator unit is housed in a tin-lined box as shown in the photograph of the unit.

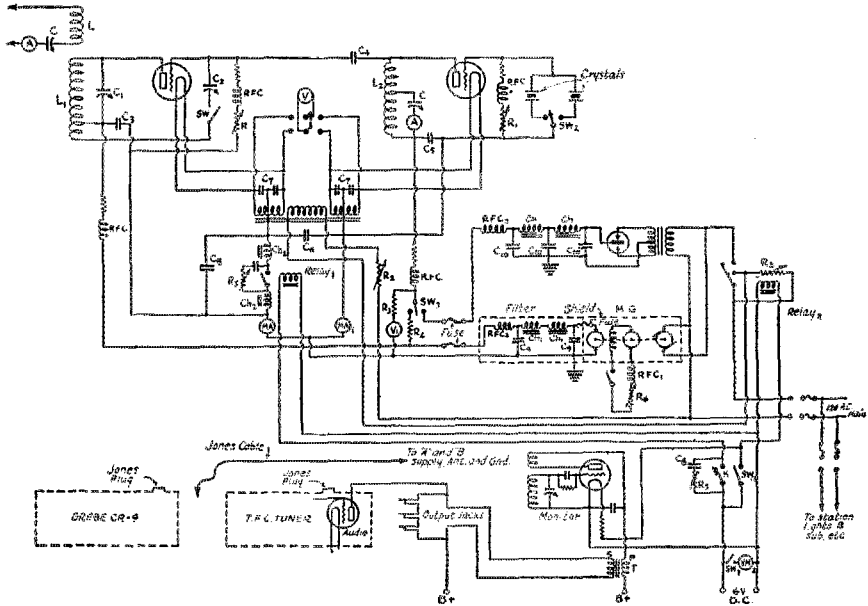

FIG. 1

- L_1 — 6-turn pancake inductance.
 L_2 — R.E.L. inductance.
 L_3 — G.R. plug-in coil, 12 turns No. 10 enameled.
 C_1 — 500- μ fd. Cardwell variable condenser.
 C_2 — 450- μ fd. National variable condenser.
 C_3 — 1000- μ fd. Cardwell, double spaced.
 C_4 — 2000- μ fd., 6000-volt Dubilier fixed condenser.
 C_5 — 2500- μ fd., 6000-volt Farndon fixed condenser.
 C_6 — 2000- μ fd., 5000-volt Dubilier fixed condenser.
 C_8 — .25- μ fd., 1000-volt by-pass condenser.
 C_7 — Same as C_6 .
 C_9 — 5- μ fd., 1000-volt by-pass.
 C_{10} — 1- μ fd., 1750-volt filter condenser.
 C_{11} — 2- μ fd., 500-volt filter condenser.
 R_1 — 0-30,000 ohm Type E Bradleyohm.
 R_2 — Type E Bradleyohm. (See text.)
 R_3 — 0-100-ohm Type E-210 Bradleystat.
 R_4 — 100,000-ohm Electrostat resistor.
 R_5 — 50,000-ohm Ward-Leonard resistor.
 R_6 — 0-300-ohm potentiometer.
 R_7 — 0-200-ohm Ward-Leonard field rheostat.
RFC — See text.
RFC₁ — 100 turns No. 24 d.c.c. 1 1/2" diameter.
RFC₂ — 50 turns No. 28 d.c.c. 5" diameter.

- Ch — 30 henry, 85 ma. choke.
 Ch_1 — 1 1/2 henry, 500 ma. choke.
 Ch_2 — 5 henry, 300 ma. keying choke.
 A — 0-3-ampere Weston type 425 r.f. ammeter.
 MA — 0-300-milliamperer Weston type 301 d.c. milliammeter.
 MA_1 — 0-100-milliamperer Weston type 501 d.c. milliammeter.
 VM — 0-15-volt Weston type 476 a.c. voltmeter.
 VM_1 — 0-5 Weston type 501 d.c. milliammeter. (See text.)
 VM_2 — 8-0-8 volt Weston type 354 d.c. voltmeter.
Relay 1 — Pony keying relay.
Relay 2 — Home-made starting relay.
SW — Neutralizing condenser disconnect.
SW₁ — Crystal selector switch.
SW₂ — Oscillator plate supply change-over.
SW₃ — Starting cam switch and station battery voltmeter switch. (See text.)
SW₄ — Generator field switch.
K — Hand key (Vibroplex).
T — High-ratio monitor coupling transformer.
Receivers are cut in on positive B supply lead before it enters Jones cable.
Crystal oscillator tube is a UX-210.
Power amplifier tube is a 50-watt low impedance UV-211.

darson power pack delivering 400 volts d.c. The high-voltage generator is normally used to supply plate power to the 50-watt amplifier only, but in event of failure on the part of the 400-volt rectifier supplying the crystal oscillator, plate

The lining, machine frame and negative high voltage are grounded to eliminate "hash." Two stacks of paper towels beneath the base absorb mechanical vibration — or rather blot it out! The small radio frequency choke mounted above the

coupling is RFC₁ of the diagram and is connected in the field lead going to the field rheostat located at the left on the front of the operating table. This choke was found necessary in eliminating a small amount of "hash" in the receiver which resulted from bringing these leads so near the receiver.

The generator output filter is contained in the compartment at the left and consists of a 1- μ f., 1750-volt condenser, two 1½ henry chokes in series and a second 1- μ f., 1750-volt condenser across the output. A fuse is cut in between the generator and filter in the positive lead for protection in case of condenser failure. The small filter allows just enough modulation to produce a mellow d.c. note. From the filter the d.c. passes through a 300-turn, 3-inch diameter radio frequency choke intended to keep any stray r.f. out of the filter and generator. R.f. is hard on filter condensers and generator windings! A lead sheathed cable carries the high voltage output to another room and to the transmitter.

On the top of the motor-generator box are located the starting relay and a.c. line fuses along with the 400-volt oscillator plate supply. The primary of the Thordarson transformer of this unit is tied in shunt with the motor so that the oscillator plate voltage comes up with the amplifier high voltage. A resistor is shunted across the contacts used for closing the a.c. supply to the primary of the filament transformer and is so

and what not. Its exact location otherwise is Lat. N 40° 57' 30', Long. W 76° 15' 6'. If you are not a navigator or a navigator's offspring, that is Hazleton, Pa., the heart of the hard coal region.

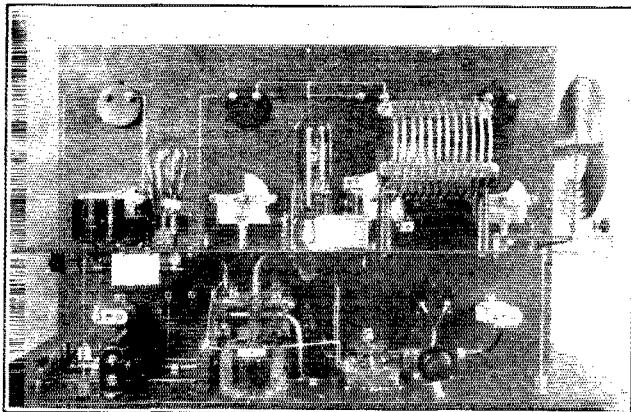

REAR VIEW OF THE 50-WATT CRYSTAL-CONTROLLED TRANSMITTER

The receiving antenna is in approximately the same location and is an indoor affair 30 feet long.

It is admitted that the equipment could be fitted with quite a few up-to-the-minute improvements. For example, in the opinion of many, the receiver sorely needs a 222-r.f. stage and a screen grid peaked audio amplifier. However, plenty of DX rolls in on the present receiver and any increase in sensitivity only adds to the QRM. In designing and constructing the entire station, the cash available for the works was limited. Keeping this all-important point in mind, for the use to

which it was intended to put the station, careful consideration was given to compensation in results and strictly unnecessary or unimportant "improvements" weighed against cost. There is often a tendency towards overdoing the job with a total disregard for this point. It is not unusual to find a station equipped with a fine and costly transmitter and a hay-wire receiver composed of junk parts — or *vice versa*. In this case an attempt was made to strike a happy medium. Cost with results desired and necessary for the relay type of station wanted were taken into consideration so as to permit the realization of a well-balanced set up with a wide operating

margin of safety and the minimum of up-keep. As to actual results and operation, they are all that could be desired. If they were not, the thing would be silent until such time as improvements or corrections could be made. Everything must perform its intended work perfectly. New ideas and the theories of others are not always taken for granted as being the last word.

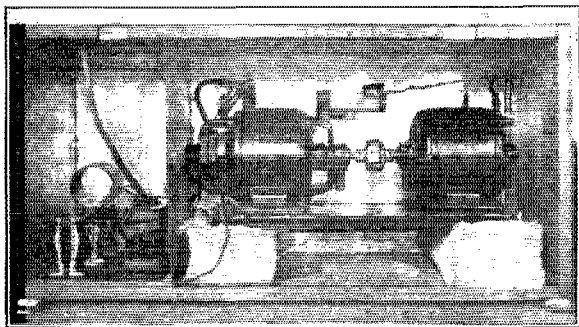

THE SHIELDED MOTOR-GENERATOR AND FILTER UNIT

adjusted that the tube filaments are at half voltage while the transmitter is idle. This contributes greatly to the life of the tubes where the transmitter is started and stopped at frequent intervals.

The transmitting antenna is a half wave for 3500 kc. (80-meter band) and is 2065 feet above sea level, 2000 of the feet being hard coal, rock

An investigation is made, variations are tried and the resultant change or improvement is incorporated if found satisfactory. This accounts for the few deviations from the beaten path. Pride is taken in the manner in which the entire station is handled; business-like operation

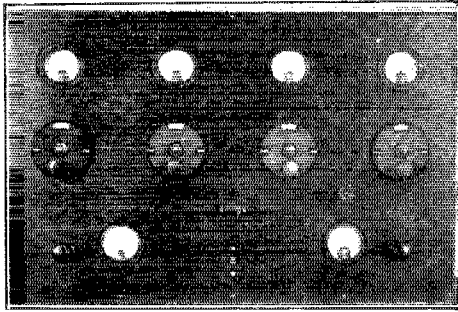

THE SYMMETRICALLY ARRANGED TRANSMITTER PANEL

with a business-like signal from a business-like station. Any constructive criticism is always gratefully received.

Book Reviews

By H. P. Westman, *Tech. Ed.*

RADIO *Operating Questions and Answers*, second revised and enlarged edition, by Nilson and Hornung. Published by McGraw-Hill Book Company of New York City. 242 pages and 91 figures with two appendices of 18 pages total. Price, \$2.00.

The fact that this book is a very queer mixture of the most modern and extremely antique and obsolete of radio equipment is no reflection upon the authors. It is due entirely to the fact that one must consider the commercial aspects of radio which prohibit from financial considerations the junking of all ship equipment that is not of the most advanced type. Therefore, it behoves those responsible for the licensing of radio operators, who may be called upon to take charge of most any sort of an installation, to include questions testing the ability of the candidate to meet those situations that are likely to confront him. The authors in their effort to fulfill their responsibility to the embryonic wireless operator must heed these conditions and it is for this reason that we find such devices as crystal detectors, spark-coil and arc transmitters rubbing shoulders with the more modern equipment based upon the vacuum tube as a detector, amplifier and oscillation generator. In addition to covering commercial ship-board conditions, a pleasant, though short chapter is devoted to amateur station practices and a somewhat longer one to the problems of the broadcast man. It should be of great assistance to the man who has had no commercial experience and must familiarize himself with that held through a textbook.

The *Radio Manual*, by George E. Sterling, edited by Robert S. Kruse, B.S. Published by D. Van Nostrand Company, New York City. Contains 654 pages and 273 figures. Price, \$6.00.

Most authors are content to write a book about a certain branch of radio but in this case the aim seems to have been to cover the field in its entirety. One may find data on ship installations, broadcast, amateur and commercial high-frequency equipment as well as fundamentals of electricity and magnetism, vacuum tube theory and operating practices. Even the present-day radio laws may be found between its covers. In short it covers modern radio design, practice and operating almost regardless of the type of station one may be considering. It is, perhaps, one of the most complete books ever written concerning practical radio equipment and methods. It is intensely practical and, being based primarily upon modern equipment, is of considerable worth to the man whose interest in radio is a wide one. Throughout, the author attacks problems from the angle of the man who must operate the equipment, making extremely little use of mathematics or involved theorizing.

The commercial ship operator will find it valuable, covering as it does not only spark, arc and tube ship-board radio equipment, but storage batteries and motor-generators as well. The broadcast station operator will, likewise, find much to interest him concerning modern broadcast equipment and methods.

The Radio Industry, published by A. W. Shaw Company of New York City. 321 pages, 30 figures. Price, \$5.00.

The reason no author's name is included in the above is because this work is the result of the efforts of a number of contributors of prominence in the radio industry. It is based upon a series of lectures delivered during 1927 and 1928 at the Harvard Graduate School of Business Administration as part of the Business Policy course.

A résumé of early radio developments is presented by Elmer E. Bucher, Assistant Vice-President of the R.C.A., which is followed by a history of radio's service during the world war written by General J. G. Harbord, President of the R.C.A. Developments since 1920 are portrayed by David Sarnoff, Vice-President of the R.C.A. The development of radio telephony as a communication means is covered by Dr. Frank B. Jewett, Vice-President of the A. T. & T. Research, and manufacturing problems are discussed by E. P. Edwards, Manager of the Radio Department of the General Electric Company.

The law of the air is presented by Judge Stephen B. Davis of New York City who outlines the development of the early radio laws and shows how the present congested conditions have come about.

H. P. Davis, Vice-President of the Westinghouse Electric and Manufacturing Company, tells about the early history of broadcasting and the modern version of the story is the work of Meriin H. Aylesworth, President of the National Broadcasting Company.

The distribution and merchandising of radio sets and the methods of advertising such equipment are covered by J. L. Ray, General Sales Manager, and Pierre Buocheron, Advertising Manager of the R.C.A., respectively. A short chapter on the application of radio principles and devices to other industries and an appendix covering some radio principles are the work of Harold C. Weber of Massachusetts Institute of Technology.

This book does not concern itself to any great extent with the technicalities of radio communication. It is primarily concerned with its past and present history and slightly with possible future developments.

Several of the papers contain a distinct undertone to the effect that there is no octopus-like monopoly strangling the industry and that a monopoly of communications should not be considered as damaging as most are wont to believe all monopolies are.

Two Recently-Announced Tubes

The UY-224 and the UX-245

By Harold P. Westman, Technical Editor

THE first title considered for this article was "Two New Tubes" but mature reflection indicated that while these two tubes were but recently announced, they were, nevertheless, new to neither the industry nor the general public. Both have been mentioned and discussed to some extent in the radio press during the past few months and the fact that they would some day appear upon the market seemed well established in the minds of most.

The UY-224 which we shall discuss first is a screen-grid tube provided with a heater for operation on alternating current. It is the much-talked-of a.c. screen-grid tube. However, one must not jump at the logical conclusion and consider it as being an a.c. "222". This is not the case and the 224 must be considered as a distinct identity having constants all its own. Although it fulfills for the a.c. operated set the function of the 222 in a d.c. operated one, it is distinctly itself and is interchangeable with no present-day tube.

It is primarily used as a radio frequency amplifier but may also be used as a detector. Operation may be with either screen-grid or space-charge connection depending upon the characteristics desired.

The normal plate and heater voltages are:

Heater voltage.....	2.5 volts a.c. or d.c.
Heater current.....	1.75 amperes.
Plate voltage, maximum and recommended.....	180 volts.
Grid bias, negative.....	1.5 volts.
Screen voltage, maximum.....	75.

Under these conditions the following characteristics are obtained; values for the UX-222 under the same plate, screen and grid voltages are given for comparison.

	UY-224	UX-222
Plate current.....	4 mila.	1.5 mila.
Screen current not over $\frac{1}{4}$ of plate current		
Plate resistance.....	400,000 ohms	850,000 ohms
Amplification factor.....	420	300
Mutual conductance, microhms.....	1050	350

DIRECT INTER-ELECTRODE CAPACITANCES

Effective grid to plate.....	0.01 μ fd. Max. 0.02 μ fd. Max.
Input.....	5. μ fd. 6. μ fd.
Output.....	12. μ fd. 15. μ fd.

The 224 is quite similar in appearance to the 222 although they may be easily told apart by

the base, the 224 having a five-prong, UY base and the 222 a UX, four-prong one. In addition, the outer screen of the 224 is considerably larger in diameter than is the 222's and one may see the insulating strip supporting the heater unit peeping out the top of the assembly. The metal cap on top of the bulb is the control grid terminal, the screen terminating at the grid prong of the base.

Heaters may be operated in parallel as long as sufficiently heavy wire is employed to handle the

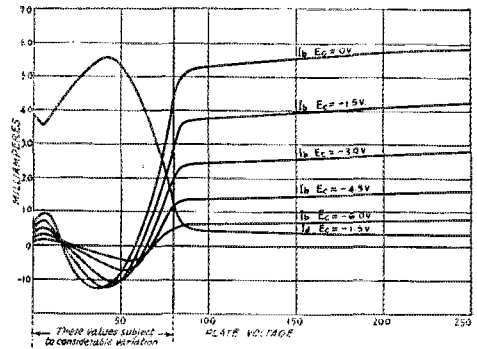

FIG. 1

Showing the plate and screen currents plotted against the plate voltage with normal heater voltage and current and a screen-grid potential, E_c , of 75 volts. I_b is the plate current and I_a is the screen-grid current. Individual tubes vary considerably in their operation at plate voltages lower than the screen-grid voltage and for this reason the portion of the curves to the left of the heavy vertical line cannot be considered as highly accurate.

current required by the number of tubes in use. All a.c. leads should be of twisted pair to eliminate hum and the connection between the cathode and the heater is preferably made to the movable arm of a potentiometer connected across the heater terminals. If a potentiometer is not provided, a center-tapped resistor should be employed or the connection made to the center of the transformer winding supplying the heater. It is sometimes helpful to bias the heater negative in respect to the cathode to eliminate residual hum. The voltage necessary to obtain all the improvement from this source that can be had should not exceed 9 volts. Tubes should not be removed from their sockets without first turning off the heater voltage as the considerable reduction in load current may cause the voltage across the other tubes to reach a damaging value.

¹The values for the 222 are obtained with normal plate and screen voltages which are 135 and 45 volts respectively.

The voltage for the screen may be obtained from a tap off the plate battery or battery substitute. It is not recommended that it be obtained by means of a high resistance between the screen and the plate voltage supply tap because the screen current will vary considerably with different tubes. The use of a potentiometer to control the screen voltage will provide an excellent volume control as the screen potential affects the mutual conductance and, hence, the effectiveness of the tube as an amplifier.

Although neutralization is not necessary to prevent oscillation, it is essential in cascade amplifiers to provide sufficient shielding to eliminate feedback external to the tubes. If this is not done, it will be impossible to realize the huge gain of which the tube is capable. Each stage should be shielded from all others and by-pass condensers and chokes provided to reduce coupling between stages through the common power supply device. Very short leads should be provided from the screen to the by-pass condenser and to the ground in order that the screen be as near ground potential as possible. Because howling or motor-boating may be caused by the use of tuned impedances as coupling units between stages, the use of r.f. transformers is recommended. Such trouble should not occur if the plate source is of low impedance, though.

The 224 may be employed as a screen-grid

resistor of between 200,000 and 500,000 ohms, 250,000 ohms being a good value, and the plate supply voltage should be raised to 200 volts. With a screen-voltage of 45, the control grid voltage should be adjusted to obtain a plate current of 0.1 milliampere when there is no signal impressed upon the grid. This bias will be about 5 volts. Grid leak and condenser detection may be employed with the same plate resistor and plate and screen voltages. Either type of detection should provide an output that requires no more than a single stage of audio amplification. The use of two stages may cause an excessive hum.

So much for the UY-224.

UX-245

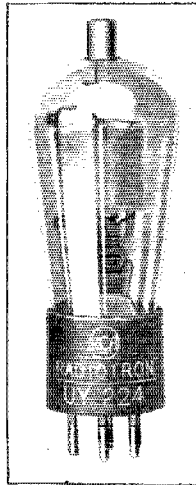

THE UY-224, AN A.C. SCREEN-GRID TUBE

Its appearance is similar to that of the UX-222 although a UY base is employed. Its electrical characteristics are quite different, though, and these tubes are not interchangeable.

The 245 is a cross breed between a 210 and a 171 with a few other characteristics. It has a low μ and is capable of delivering over a watt and a half of undistorted power with a plate voltage of but 250. To make things more interesting, the filament is of the "heavy" variety and may be operated on either a.c. or d.c. requiring 2.5 volts and 1.5 amperes to get properly "het" up. It is, therefore, possible to build a set with all the necessary types of r.f., detector and power tubes without requiring more than a single filament voltage. The importance of this fact may be realized by attempting to wire up a receiver em-

ploying three different types of tubes no two of which have the same filament or heater characteristics.

The following tabulation will give some idea as to the position of the 245 in respect to the other tubes devised for last stage operation.

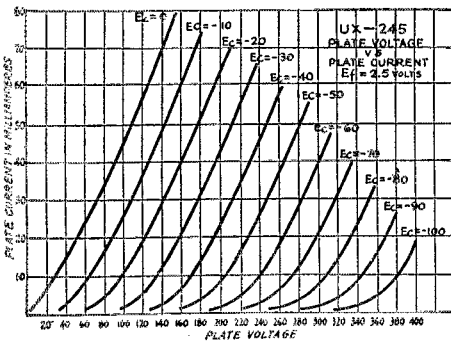

FIG. 2

In these curves, the plate current is plotted against the plate voltage for various values of grid voltage. By drawing in suitable load lines, the output and amount of distortion may be calculated.

detector and although it may be operated with either grid condenser and leak or grid bias, the latter is preferred. The plate coupling should be a

	UX-245	UX-171-A	UX-210	UX-250
Plate voltage	180 250	180	425	450
Plate current, ma.	26 32	20	18	65
Grid voltage, negative	33 50	43	39	84
Peak grid swing	33 50	43	39	84
Plate resistance, ohms	1950 1900	2000	5000	1800
Amplification constant	3.5 3.5	3	8	3.8
Mutual Conductance, microhms	1800 1850	1500	1600	2100
Undistorted power output, milliwatts	780 1600	720	1600	4600

The most impressive fact is that it is possible with a plate voltage of but 250 to obtain with a UX-245, the same undistorted output rating as can be had from a 210 with 425 volts on the plate. If we had had this tube a few years ago think of all

the wear and tear on filter condensers that would have been saved, to say nothing of worry and trouble to the manufacturer of these units. However, the industry has probably learned a few

the program was carried out to the letter. With well chosen words, President Sias, of the Springfield Radio Association, which sponsored the convention, extended a cordial welcome to the delegates which was responded to by Treasurer Hebert of A.R.R.L. Headquarters, who also expressed his thanks to the Springfield Chamber of Commerce for their fine cooperation in handling the publicity.

With practically every Section Communications Manager in attendance, a very instructive meeting took place in the afternoon — principal remarks being made by Director Best, who made his first appearance in his official capacity, and by Communications Manager Handy.

Assistant Radio Supervisor Butterworth and Junior Radio Inspector Weston had their hands full with examinations for operator's licenses and some 55 fellows are now

possessors of a regular ticket.

A precedent was established by serving supper to the gang. This kept every one together, and after the tables were cleared a general stretch was had by every one before settling down to listen to the "liars" and "stunt-pullers." Woodrow Darrow, WIAOZ, was the best liar and Bailey, W1KH, the second best. Those two have some imagination.

One of the pleasant surprises of the convention was the visit to the plant of the Westinghouse Electric & Manufacturing Co. at Chicopec Falls, a short distance from Springfield, where Mr. Hutchinson of the Radio Engineering Department, played host. This trip proved most instructive and gave the delegates an opportunity to see the latest development in short-wave commercial transmitters, direction finders and motion-picture talkies. We are, indeed, very much indebted to Westinghouse and Mr. Hutchinson, for the courtesies extended. A visit to WBZ was also made.

Saturday afternoon had so many good items on the program that it kept the big crowd interested all the time. C. N. Kraus, W1BCR, gave a good talk on television, and demonstrated its principles. Mr. Kraus also showed some 5-meter experiments. Col. Van Horn, Signal Corps, U. S. Army, made a few remarks on the Army-Amateur Net Work and then introduced Capt. J. C. Platt, Jr., Signal Corps Liaison Officer, who reviewed in detail the present Net Work and what such an arrangement means in time of

(Continued on page 82)

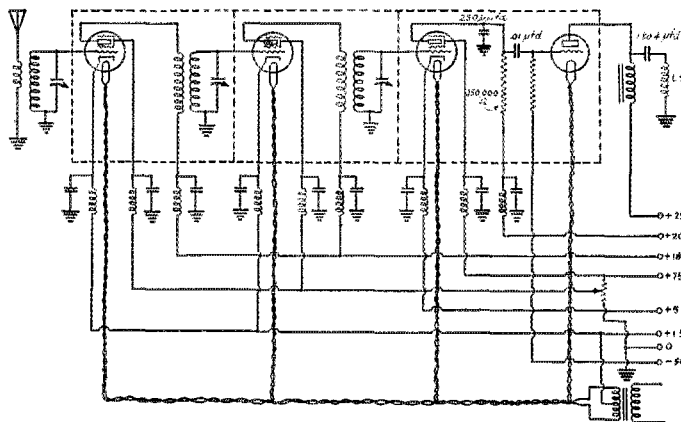

FIG. 3

This circuit shows two UV-224's employed as radio-frequency amplifiers and a third as a grid-bias detector. A single audio stage using a UX-245 is provided. All battery leads are by-passed with 0.01 µfd. condensers which in conjunction with the r.f. chokes shown, prevent coupling between stages due to the use of a common power supply system.

things about the manufacture and rating of filter condensers so the public should be somewhat ahead on the works.

There is little more need be said about this tube other than that the windings of a loud speaker are not normally designed to carry currents of 25 or 30 mills and a suitable output device must, therefore, be provided. This may be in the form of an output transformer or choke and condenser rig. The latter arrangement is shown in the circuit diagram and note should be taken that the return from the speaker goes to the B-terminal and not to the low side of the choke. This saves the a.c. the trouble of wandering through the "B" substitute and, perhaps, elsewhere.

As in the case of the UX-250, the UX-245 is not designed or recommended for oscillator work and although it may be possible to obtain satisfactory operation with some of the tubes, trouble from secondary emission from the grid will normally be encountered. It should, however, make a nice output tube for the low-powered oscillator-amplifier transmitter, the maximum plate voltage needed being but 250.

The New England Division Convention

SPRINGFIELD, MASS., was the Mecca of "Hams" from all over New England on April 19th and 20th. With the largest registration on the first day of any previous convention the committee in charge saw to it that

Experimenters' Section

IN accordance with the arrangements outlined in the last Section report, we are presenting this month the outline on problem R12 covering radio-frequency amplification for amateur bands.

PROBLEM R12 — RADIO-FREQUENCY AMPLIFIERS FOR THE AMATEUR BANDS

The problem of radio-frequency amplification offers two distinct methods of attack; amplification may be obtained at the signal frequency or the use of an intermediate frequency may be resorted to in order to obtain the necessary gain and stability. This latter method received most attention and gave better results for many years but with the advent of the screen-grid tube, the problem took on a decidedly different aspect. It is now possible to amplify at the signal frequency with satisfactory gain and stability. As in any other like subject, though, there are many differences of opinion as to the most desirable characteristics and the problem of simplifying the control of r.f. receivers is an important one. The use of shielding as well as the filtration of common battery leads calls for considerable attention. One must also take cognizance of the tuned vs. untuned angle of the case. Taking the subject by and large, much has already been done and still more remains to be accomplished. The past history may be obtained from the following bibliography.

QST

The Neutrodyne C.W. Tuner at 9ZT. (Wallace) Jan. 1925.
 Measuring Very Small R.F. Currents. (Turnbull) Jan. 1925.
 The Regenaformer. (Browning) April, 1925.
 The Isorad Receiver. (Minnium) May, 1925.
 Improving the R.F. Amplifier. (Burns) May, 1925.
 Measurements of the Voltage Ratio of Audio and Radio Transformers. (Ramsey) August, 1925.
 Adding Punch to Your Neutrodyne. (Budlong) Sept. 1925.
 A True Cascade R.F. Amplifier. (Hull) October, 1925.
 The One-Stage R.F. Amplifier. (Pendleton) Nov. 1925.
 A Three-Tube Neutrodyne for Short Waves. (Ablowich) December, 1925.
 Shielded R.F. Stages. (Clayton) September, 1926.
 R.F. Amplification — A Rehash. (Lyford) Nov. 1926.
 A Short-Wave R.F. Amplifier. (Bouck) Nov. 1926.

A Short-Wave Super-Regenerative Receiver. (Dallin) January, 1927.
 Radio Frequency Transformer Design in Voltage-Stabilized Systems. (Marco) Feb. 1927.
 Theory of a Tuned R.F. Transformer. (Browning and Drake) March, 1927.
 Some Tests With R.F. Amplifiers Below 200 Meters. (Deckendorf) May, 1927.
 An R.F. Amplifier of Uniform Sensitivity. (Mesa) May, 1927.
 A Super-Regenerative 5-Meter Receiver. (Jones) June, 1927.
 A Combined Super-Heterodyne and Detector-Audio 20-Meter and 5-Meter Receiver. (Kruse) June, 1927.
 This Short-Wave Amplifier Business. (Bourne) Aug. 1927.

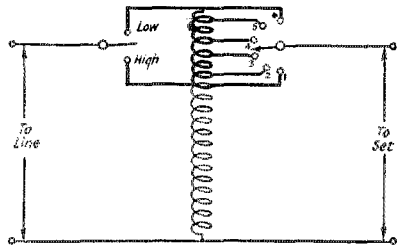

FIG. 1. — THE CIRCUIT ARRANGEMENT OF THE AUTO TRANSFORMER IS GIVEN ABOVE

It will allow the voltage applied to the load to be either above or below the line voltage depending upon the position of the two switches. When the line tap is connected to a point between the top of the winding and the tap to the load, the voltage across the load will be lower than the line voltage. When the line is connected to the winding at a point between the load tap and the bottom end of the winding, the load will be at a higher voltage than the line.

The UX-222 Shield-Grid Tube. (Kruse) Dec. 1927.
 The Shield-Grid Tube As an R.F. Amplifier. (Kruse) Dec. 1927.
 Short-Wave R.F. Amplifiers. (Westman) Dec. 1927.
 Getting the Most Out of the UX-222. (Bourne) Dec. 1927.
 Double-Detection Receivers With Band-Pass Filters and Screen-Grid Amplifiers. (Taylor) March, 1928.
 The UX-222 As a Short-Wave Amplifier. (Lidbury) April, 1928.
 A Super-Regenerator for Short Waves. (Hart) July, 1928.
 A Super-Heterodyne for High Frequencies. (Gluck) Oct. 1928.
 Receiver Characteristics and Their Measurements. (Landon) Oct. 1928.

- High-Frequency Receivers for the Coming Year. (Hull) Nov. 1928.
- An Improved Super-Heterodyne. (Grigg) Dec. 1928.
- A 1929 Receiver. (Hendricks) Feb. 1929.
- Improving Short-Wave Phone Reception. (Hull) March, 1929.

PROCEEDINGS OF INSTITUTE OF RADIO ENGINEERS

- The Limit of Regeneration. (Little) Aug. 1924.
- An Analysis of Regeneration. (Landon and Jarvis) Dec. 1925.
- An Efficient Tuned Radio Frequency Transformer. (Browning and Drake) Dec. 1925.
- Combined Electromagnetic and Electrostatic Coupling and Some Uses of the Combination. (Loftin and White) Oct. 1926.
- Influence on the Amplification of a Common Impedance in the Plate Circuits of Amplifiers. (Anderson) March, 1927.
- Notes on Radio Receiver Measurements. (Smith and Rodwin) May, 1927.
- A Mathematical Study of Radio Frequency Amplification. (Smith) June. 1927.
- Measurements of Radio Frequency Amplification. (Harris) July, 1927.
- Note on R.F. Transformer Theory. (Diamond and Stowell) Sept. 1928.
- A Method of Treating Resistance Stabilized Radio Frequency Amplifying Circuits. (Snaveley and Webb) Jan. 1929.

Obviously all of these references do not directly concern themselves with high-frequency amplifiers. However, many of them contain material of interest and importance which is applicable to

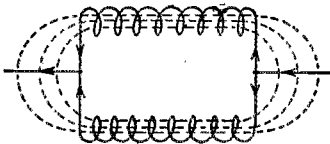

FIG. 2. — THE BINOCULAR TYPE OF WINDING DISCUSSED IN THE TEXT
 The magnetic field threads through both coils and there is little external field. Because two coils are in parallel, each will have to be larger than a single coil if it were employed.

the problem in hand and a study of them can only improve one's knowledge of the subject and help considerably in the final analysis.

A BOOSTER TRANSFORMER

Just after dark when the DX gets good and the peak load is placed on the 110-volt line and you watch your plate and filament voltage slide off until you couldn't raise Oshkosh, how you long for a hokus that would squeeze a few more volts out of that line! Well, the object of this little squib is to tell how to make such a thing.

It is our old friend the auto transformer and it may be used either to reduce the line voltage or increase it depending upon the manner in which it is connected to the line and load. The primary winding is not called upon to handle the entire load and so can be wound with fairly light wire. For general work 400 turns of No. 20 d.c.e. wire wound on a core whose cross section is $1\frac{3}{4}$ inches by $1\frac{3}{4}$ inches will do. A window $2\frac{1}{2}$ inches long by $1\frac{1}{2}$ inches wide will do nicely and will make the outer dimensions of the core 6 inches by 5 inches. Standard laminated core material should be used and a pile 3.5 inches high of $1\frac{3}{4}$ by $1\frac{1}{4}$ inch pieces will do for the two long legs. The shorter legs will require a $3\frac{1}{2}$ inch pile of $1\frac{3}{4}$ by $3\frac{1}{4}$ inch material.

The secondary winding may consist of 100 turns of No. 14 d.c.e. wire wound either over the primary or on the other long leg of the core. This winding should be tapped every five turns so that

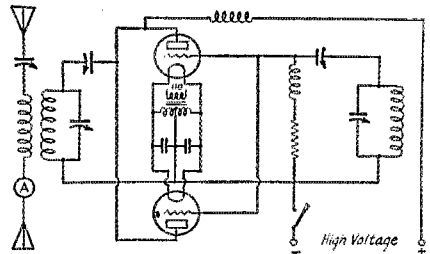

FIG. 3. — THE CIRCUIT DIAGRAM OF THE TUNED-PLATE, TUNED-GRID TRANSMITTER SHOWN IN THE PHOTO

A pair of 210's is connected in parallel.

the output voltage may be varied to suit the characteristics of the load. These taps should be brought out to a heavy-duty tap switch and connected to only every other switchpoint so as not to short circuit part of the winding when running the switch blade across the points. It is, of course, not absolutely essential that a switch be provided, the change can be made by means of a heavy clip as long as good contact is made with the tap.

By means of the transformer, the line voltage can be increased by approximately 25 per cent or decreased by about 20 per cent depending upon the connections employed. It is good practice to obtain the use of a suitable voltmeter and measure the voltage obtained under the many possible connections and make a record so that there will be no guess work involved when making a change. It must also be remembered that the line voltage is usually lowest at about nine o'clock in the evening, rising steadily until it gets back to normal. Don't set the transformer to operate properly under the lowest line voltage and then turn the set on the next morning when the voltage is high without previously making the proper readjustment to suit the changed condi-

resistance which means that the wires may be smaller which reduces the distributed capacity.

If the fields of the two coils did not interlink the inductance of either alone would be

$$L_0 = \frac{4\pi^2 a^2 n^2 k}{l}$$

from Nagokoa's formula where k takes into account the leakage flux. Since the leakage flux is diminished when the fields interlink by the amount of the mutual flux which varies with the proximity of the coils and their physical dimen-

will, so it is doubtful if much advantage would be had by using such a coil in the plate circuit.

A LOW-POWER TRANSMITTER CHASSIS

By A. Binneweg, Jr.*

The electrical details of low-power transmitters as used in the majority of amateur stations have been discussed many times in these columns. An efficient transmitter employing the tuned-plate, tuned-grid circuit is shown in the illustration. Its electrical features do not depart greatly from the usual transmitter employing the same circuit. However, the mechanical arrangement of the set has some distinct advantages as will be described.

The proper coupling between the primary and antenna coils is important and is often difficult to secure especially if the coils are mounted efficiently as in this set. It is usually good practice to mount the antenna coil rigidly which means that the plate coil must be adjusted in some way.

As shown in the illustration, the entire set is mounted on a light wooden frame that slides in a second similar frame by means of loose tongue and groove joints. This second frame is arranged so as to move freely upon two rails at right angles to the motion of the first frame. It is obvious that there should be little difficulty in securing the proper coupling if the set is mounted approximately in correct relation to the antenna coil at the start.

In this arrangement the only leads that need be flexible are the plate and filament leads and a little bending of these while experimenting for proper values is of no consequence. All connections are made to large posts on a bakelite piece at the rear of the set. The filament-by-pass condensers are mounted directly across the filament posts.

The mechanical arrangement of this set should appeal to the amateur who goes about the design of his transmitter in a systematic manner. It is of the "open" type of construction which appeals to the visiting radio friends and allows changes to be made easily and readily.

All dimensions and details of the transmitter and chassis are given for those who wish to duplicate an arrangement which has proved both simple and flexible in practice. Although the electrical details do not depart from the usual, a circuit, Fig. 3, employing a simple antenna is given.

* 425 Fairbanks Ave., Oakland, Calif.

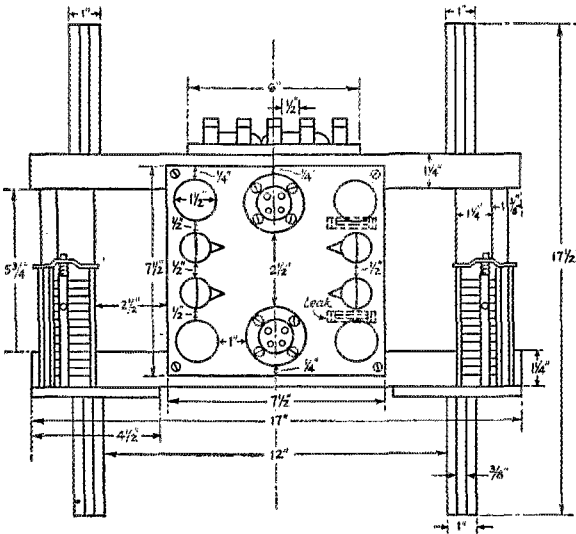

FIG. 5. — A PLAN LAYOUT OF THE TRANSMITTER SHOWING THE GENERAL ARRANGEMENT OF THE VARIOUS PARTS

The tubes, chokes, leaks and blocking condensers are mounted on the center platform while the two tuning condensers are arranged on small panels at the sides.

sions, no exact formula for the correct number of turns can very well be expressed.

If there were no interlinkage the number of turns for a coil of inductance $2L_0$ would be $\sqrt{2n_1}$ where n_1 equals the number of turns for a coil of inductance L_0 . Therefore, it is safe to assume that the number of turns for each of the two solenoids will be $n_2 < \sqrt{2n_1}$ or if your coil has 10 turns, you could use two coils properly wound in parallel of less than 14 turns each. The diameters will remain the same.

The oscillating circuit losses will not have as great an effect on the grid voltage impressed on the detector as the gain factor of the grid circuit

How to Photograph Your Transmitter By Electric Lights

By E. H. Harrington, Jr.*

AS ham layouts are so frequently in dark places where it is difficult to get proper illumination for taking photographs by any usual means, I am passing on the following information in the hope that it will be helpful to others who wish to keep a photographic record of their various radio stations, or are considering writing up their stations for *QST*. The results from this method are usually better than from photographs taken by daylight. It also has the advantage that the operation can be performed at any time of day or night with equal results.

Any ordinary folding pocket Kodak or similar camera — or even a box type of camera — will be perfectly satisfactory. A tripod is convenient, but if one is not available the camera can be firmly placed on a box or table at the correct distance and elevation.

The only equipment necessary, in addition to the camera, is the source of light. This should have a reflector made of white paper or smooth-surface cardboard two or three feet across. This may be used flat, or, better, conical in shape, made after the fashion of the cardboard diaphragms commonly used in cone speakers. Next take a 200-watt Mazda bulb and screw it into the socket on the end of a cord, forcing it through the center of the reflector. If a 200-watt bulb is not available, two 100-watt bulbs or four 50-watt bulbs may be substituted. If more than one bulb is used they should be mounted so as to be concentrated as nearly as possible in the center of the reflector.

To take the picture, focus the camera on the subject and stop down the lens to about f.16. In using a box type camera remember that the focus is fixed and the picture cannot be taken closer than about six feet. When this type camera is used, use the smallest sized opening. Now shut all door and window openings, if photographing in the daytime, to exclude light other than will be supplied by the source you have prepared. Set the shutter for "time exposure," open it, and direct the light from the reflector on the subject. Holding the reflector in your hand, move it around so that the light from it shines on the object from various angles, always being careful, however, that you do not get anywhere near into the field of vision of the camera. The light source should always be back of the camera or well to one side of it so that the direct light can never

fall on the lens. Keep the light moving during the whole exposure in order that, by coming from various angles, all parts of the subject will be well illuminated, and deep shadows eliminated. Direct the light onto the darker parts of the subject most. In this way the lighting will be balanced so that the details in the darker parts will show up well. When the subject as a whole is fairly light-colored, the total exposure should be three or four minutes. With medium colored subjects the time should be four to five minutes and for dark subjects five to six minutes. The "latitude" of modern Kodak film is very great, so that it is not difficult to gauge the exposure closely enough to get a perfectly satisfactory picture. However, it is a good plan and will sometimes save trouble to take two or three pictures while the arrangement is all set up, giving different times of exposure, in order to be sure that one or the other will be just about perfect.

The time of exposure is somewhat dependent on the size of the layout you are photographing. A large set covering a whole table will require a somewhat longer exposure than a "close-up" of a single piece of apparatus.

Remember that during the exposure the camera and the object being photographed must be perfectly steady. The slightest movement will make the picture fuzzy.

If your layout happens to be in front of a window, or if there is a window in view, it is usually better looking if the window is shown without the shade drawn. It is possible to do this — but not by leaving the shade up all the time the picture is taken. That would result in fogging the whole picture. The picture should be taken in the fashion described, making sure that the shade, when drawn, is a nice snug fit to the frame, so that its outlines are not too apparent. Then after taking the picture and having closed the shutter, leave the camera and everything else exactly in position, but put up the window shade. Then take another exposure, either an instantaneous snapshot or a "bulb" exposure of a fraction of a second. This will get the bars in the window and make the whole picture more natural. Of course this must be done by daylight.

[After having taken a couple of good shots of your layout as described by Mr. Harrington, write up a description of your station and send it all in to *QST* as your entry in the Station Contest. See page 37 of the March issue of *QST*. — EDITOR.]

*9CRR, 323 W. Exchange St., Geneseo, Ill.

The Communications Department

F. E. Handy, Communications Manager
L. R. Huber, Asst. to Coms. Mgr.
1711 Park St., Hartford, Conn.

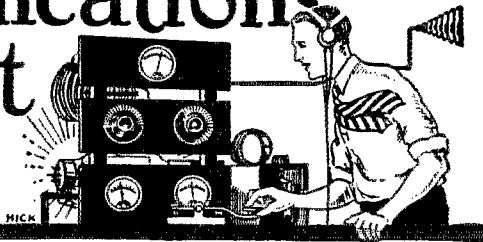

What Is an Amateur?*

By John Escobar**

A RADIO amateur is a person who is possessed of the desire to accumulate quantities of coils, condensers, and tubes that he can connect together. With them thus connected, he turns a switch, presses a key, and sends a call forth into the next state, country or continent. Such a person can boast that he is a radio amateur.

But let us go further. Can he boast that he is a *good* radio amateur?

Are the coils, condensers and tubes that he accumulates hooked up in the best possible manner, so that when he turns on his switch his tubes can glow with honest pride over the assembly of gadgets and thingumbobs and doodlinguses that adorn his table? When he presses his key will the signal thus sent forth be the clean-cut and pure note that we have come to expect of present-day transmitters?

When his brother in the next state or country or continent hears this signal will his eyes brighten with satisfaction and will he smile and say, "Ah! there is Brother Duzzenright. Has he not the *good signal*?"

Or, when the brother across the way hears the signal, will he bite his lip and scowl and mutter oaths and curses?

A radio amateur is a radio amateur; but is he a *good radio amateur*?

Let us suppose that he *does* have his whiffetits and dingbats and whatcham callits connected and adjusted properly, and that when he steps on the brass the resulting signal is clean-cut and sharp and, forsooth, when his neighbor hears it he is moved to admiration. The transmitter, we shall suppose, is in keeping with the very best precepts.

Then let us notice if this radio amateur sends properly. Are the dots and dashes that he forms of the right length? Does he leave enough spacing between the letters of every word? And does he leave a double space between words, in order that the man in the next state will be able to copy his sending "letter perfect"? Does he know the legitimate abbreviations and the Q signals — *know them*?

Or does he slouch down in his chair, rattle away at his Vibroplex, and listen for a reply to a signal that would hardly be readable even to the sender, if he should take the trouble to listen to it? Does he spend hours gumming up the ether with small talk about his and the other fellow's "sweet" and "xtal" notes?

A radio amateur may have a good signal, but is he a **GOOD OPERATOR**?

Now we shall presume that our model has an excellent transmitter and an excellent signal, and that his operating is the very best. Next we shall ask about his attitude toward others.

Does he stay within the legitimate amateur bands? If he is a DX man does he concede to his brother the traffic man the respect that he thinks he himself deserves? If he is a traffic man is he liberal minded toward his fellow the DX man?

* A talk presented before a meeting of the Hackensack Radio Association.

** W2CRO — 27 Poplar Ave., Hackensack, N. J.

Is he industrious in his adopted art? Does he take the trouble to study *QST* and the Handbook so that he can cure key clicks and maintain the good performance of his transmitter and receiver?

Or does he let George, the next-door BCL, worry about the key clicks?

Does he keep his station in condition for inspection so that he could show it to the Supervisor of Radio with pride? Let us hope that he does, and that he could show likewise his log and message file carefully kept and with all important data neatly penciled, penned or typewritten in just the corner it should occupy.

When the station is fully considered, what of the amateur as a man? Does he take an interest in the betterment of amateur radio in all its phases? Does he attend local club meetings and do all that is expected of him in the business of keeping up local and national organization? Does he pull with a will toward a logical and sensible goal — *the right thing at the right place at the right time*?

Or does he haul back on the reins and mewl and complain because somebody in the lead has, he thinks, done something that does not exactly suit him, but which, nevertheless, required a good deal more work than he was willing to put forth?

You, and I — we are both, perhaps, radio amateurs, and we enjoy our hobby. But if we look further we shall discover in addition that we can be **GOOD** radio amateurs and thereby increase the enjoyment of our hobby manifold.

28 MC.

MORE and more progress is being made in the use of this frequency, and a great deal of this work due to increasing use of 28 mc. on the part of amateurs in foreign lands.

W9EF (Wm. Short, Hammond, Indiana) has some fine work to his credit and has also gathered in a fine bunch of data on 28-mc. conditions and results — most of the information from other countries being received in the course of 14,000-ke. operation.

ZL2AC heard both W6AM and W7ACS on 28 mc. on March 10th. G5HS received 28,850-ke. transmissions from W9EF March 3d at 1700 Greenwich. March 17th appeared to be a poor day for work on this frequency, W2JN, NKF, and west coast stations reporting no signals at all heard on this date.

VT2KT (India) has had two-way communication with seven different English and one Finnish station! VK5HG has also worked VT2KT for the first VK-VT-28 mc. QSO. The first 28-mc. contact between the U. S. A. and Australia occurred when VK3CP worked W6BCS April 1st at 0250 Greenwich. This was followed by another contact between W6BCS and VK3PM. Only forty watts input were used at VK3CP and W6BCS! On April 7th both VK3PM and VK3CP heard W9EF (at 6:25 p.m. CST) and it is thought that this is the longest distance yet recorded for either transmission or reception on this frequency. PY1AA has worked two-way with LU2AA and he also reports hearing W2WS on April 7th. K6EHA is working on 28 mc. also, and has been heard by VK3BK.

VK3CP gives us the following list of 28 mc. calls heard (by radio via W9EF): VK4BR VK3WG VK3PM VK3OT VK3MY VK3LP VK3KS VK3KB VK3HR VK3DC VK3BQ VK5HG VK6SA ZL2AC ZL1FT ZL1AN ZL1AO W9EF W6XG W6JU W6FS W6BCS J1TX KLL HJO W1Y W1Z VK3CP; also says, "The first two week-ends in April were filled with QSOs and tests with ZL and VK. It was determined that it was possible for us to hold two-way communication with ZL for eight consecutive hours. NKF was QSA3 to QSA5 from 2040 to 2120 Greenwich. My antenna is three times full wave for 10.4 meters. Am now trying a half wave horizontal antenna with reflectors."

PY1AA ran a 28,850-ke. test with W9EF on April 9th from 2000 to 2100 Greenwich, and obtained solid copy on W9EF's signal (QSA4 to QSA5) on every test transmitted. Although PY1AA's frequency was known W9EF was unable to hear him. It was cloudy and overcast in Hammond at the time.

OH2NM had the pleasure of making a Europe-Asia contact when he worked VT2KT on February 10th at 1150 Greenwich on 28mc. OH2NM was reported QSA5 in India, and VT2KT was QSA2-QSA3. OH2NM used 80 watts input to a Philips Z3 tube with an aperiodic antenna about 40 meters long. VT2KT used 9 watts input. OH2NM has heard F8CT, FM8RIT and G6HP on 28 mc., and worked two of these latter stations. VT2KT logged OH2NAP on February 10th at 0935 Greenwich Q2A5. G5YK is now believed to have made the first contact between England and India (1130 Greenwich, February 10th), this two-way work resulting from a schedule arranged by Rodman of VT2KT prior to his departure from England in January. G5YK's second contact with VT2KT on February 21th was somewhat more satisfactory than this first QSO with improved signal strengths in both directions.

D1UAH is anxious to establish communication with the U. S. A. on 28 mc. and reports hearing W2JN and W4NH with excellent audibility. D1UAH is believed to have established the first 28-mc. communication between Germany and South Africa when he worked Z85C on 10.38 meters between 1600 and 1640 GCT with an input of about 25 watts.

K1CM has had good two-way communication with both Australia and Japan on ten meters. VE2AC reports that conditions in this band were rather poor during late March and early April. His signals were reported heard at 68AAP and by a station in Norway.

W2CP and W9ECZ pass along the request of several Australian stations that U. S. A. amateurs listen on 28 mc. from 0100 to 0300 GCT Sundays (8 to 10 p.m. EST Saturdays) for a bunch of VK stations working on 28 mc. A number of west coast QSOs have already been made and as many stations as possible should look over the band at this time. W6BCS has been working on 28 mc. since March 31st and in two weeks he heard VK3CP, VK3MY, VK3PM, ZL1AO, and ZL1FL, having good two way QSOs with VK3CP and VK3PM as early as 6:30 p.m. PST. Unfortunately W6BCS' operator left for his ninth district address in mid-April, so there will be no more 28 mc. reports from him for a time. W4BL has been worked in addition to the Australian contacts and in spite of "Ford automobile" ignition QRM. PY1AA has heard W2ALW, W9EVC has heard a number of weak 28 mc. signals and received a number of good reports from all along the Atlantic coast, also finding that the closest station he could work successfully was W8ZG, W9DKM has been received on this frequency but weaker than the east coast stations. An automatic key is now in process of construction, after which tests on 28 mc. will be run for extended periods.

Puffs College (W1XAW-W1KN) is now equipped to undertake transmission experiments on 28,000 kc. on regular night and day schedules using a 500-watt transmitter. Also definite attempt at two-way contacts with other stations equipped for 28-mc. work will be made.

The 28-mc. tests arranged by the Radio Society of Great Britain were held during one of the worst periods for 28-mc. work which has been recorded since the opening of the 28-mc. band. Few two-way contacts were made. However, a number of signals were logged in the short period when signals were good. Brief reports from participating stations follow:

G2CX: (heard) W2ACN W2JN W1ZZ W2AYR W2ALW W2BVG W9DHK
(QSO) W2AYR
G16YW: (heard) FM8RIT W2BHQ W2JN W2BVG
G15WD: (heard) FM8RIT W2ABC W2JN W2BHQ
G6LL: (heard) FVM2 W2BOK W2JN W2BHQ W9DHK
W1ZZ W3ADY NKF W2XAW
(QSO) W2BHQ W2JN
G6WN: (heard) W2ACN W2JN NKF W2XAW
BR519Q: (heard) W2ALW W2AYR W1ZZ W2BVG
W2JN W2ACN W1RY W5YG W2BHQ W9DHK
W1BAE Z85C W1AQD NKF
BR536: (heard) W2JN W2ACN W2AYR W2ALW
W2BHQ
BR525: (heard) W2JN W2AYR W2ACN W2BOK
W1ZZ W2ALW W2BHQ W3ADM W2BVG
W9DHK NKF W2WI
G5YK: (heard) EU2FA ?2A1 W1BAE W1ZZ
(QSO) W2JN
E17C: (heard) OMJCF W2JN W2BHQ W2BVG
(QSO) W2JN
G6DH: (heard) FVM2 W4NH W2JN W2ACN W2BOK
W2AYR W2BHQ W2ALW W3ADM W1ZZ
W1AQD W1BAE
OK2YD: (heard) RGV W2JN W1BW W1XAM
WSDAS LSF DFI E17C RWX WSAXA W1CMF
W1Z WQA (harmonics).

TRAFFIC BRIEFS

"LJ" of WSBS (the Yacht *Carnegie*, 9045 kc.) expresses the opinion that there ought to be a regulation against a fellow's sitting on the key by the half hour while watching the meters and having a smoke, and he doubts if the average run of ham signals have improved much in either quality or steadiness yet. If something really happened to these signals, it would appear that tuning and testing was in progress, but nine times out of ten the signals are steady. "LJ" also suggests that all this heavy tuning and adjusting should be carried out during the daytime, and not in the busiest operating hours, evenings. If the sets were properly tuned up, as in any good fixed station, all that would be necessary during rush hours would be a preliminary warming up requiring not more than a half minute. Then, too, these long drawn out talks with full words and six unnecessary calls do no good and lots of harm. The International Q Code and miscellaneous abbreviations were designed to minimize QRM and conserve operating time. So why not always make the conversation snappy by using plenty of abbreviations, and the internationally understood abbreviations whenever and wherever possible! "LJ" says you should all listen to the ole U. S. A. bands from down in the South Seas — and then improve those operating practices!

This flopping all over the band and "tuning up" during the evening operating hours is a "ham" operating trick and no mistake. Why not pick a frequency where the equipment works best and stick to it. The "best" stations use known frequencies and keep schedules consistently — and their ops always know where to find each other for the most efficient handling of routine traffic work.



POUNING GRASS WITH PLEASURE

QSP?

By Vincent Berry*

Mr. Berry wins second prize in our article contest this month. His contribution again emphasizes the importance of "deliveries" and the desirability of originating only good and worthwhile messages. — EDITOR.

DID you ever stop and think about amateur radio from a different view point than that of an amateur? Try it once and maybe you will have a different point of view from an amateur standpoint.

You see different things that don't occur to you when you are pounding brass. Take for instance the distance you can cover when you work another station. A thousand miles or two does not mean much to you, but to the average person the chance to talk with someone a thousand miles or more away is the thrill of a lifetime. Did you ever listen to the voices of people to whom you have QSP'd messages and noticed how glad they were to get news from their friends or relatives? The tone of their very voice is enough to prove to any amateur that he has indeed done someone a great favor. More than once I have QSP'd via the telephone and let me tell you, the thanks that they give you are not the kind that the hams sling around after they get a report on their sigs. It is an honest to goosh thanks — al-

most "88!" Often I have given a message over the phone and then sent the answer to the waiting station at the other end and he would deliver it in a few minutes. Do you think anybody was sorry that we made such short work of a message over a distance of a thousand miles? I don't; I enjoyed it immensely, and I am sure that the other operators got some pleasure out of it.

By checking, I have discovered that about three messages, out of over fifty sent, have been delivered. This is a rather low percentage and so I suppose there are some stations with only a hook for originated messages and a stove for those that should be delivered. I am inclined to believe that these are far in the minority and that I had just hit a streak of bad luck.

If you haven't the time or don't feel like handling traffic, for goodness sakes, don't take any and if you do, don't make the stove your mail-box. One cent for a post card will do the trick and you have done someone a kindness besides.

Let's cut out the rubber-stamp messages and have a few real messages. What we want is quality, not quantity.

* W6DHM, 4544 Toland Way, Los Angeles, Calif.

Don'ts for DX

By Frank E. Dailey*

In March QST, page 62, the Communications Department invited contributions on every phase of amateur communication activity, offering prizes for the best article selected from those submitted during each month of 1929. A wide variety of subjects on which articles would be welcomed were suggested in the original announcement. In addition to these articles receiving a good position in QST, the authors whose articles appear to have the greatest value of those sent in for consideration each month have the choice of (1) a copy of the Radio Amateurs' Handbook bound in algerian, (2) six pairs of A.R.R.L. message blanks, or (3) 500 A.R.R.L. lot sheets.

The prize winning article by Mr. Dailey asks for more use of plain common sense in attempting to "work DX" and there is much food for thought in what he has to say. Improved operating procedure will better conditions in all our bands. With but a single CX310 the author has worked amateurs in fourteen different foreign countries and in every state in the U. S. A. from a location in the central part of the country — and not one of these on his CQ! So we think he has earned a right to be heard. Quite possibly if it is thoroughly demonstrated that amateurs fail to cooperate effectively in these operating matters, more legislation, regulation, and supervision will be invoked in the future to improve conditions. We sincerely hope that satisfactory remedies can be found in a higher degree of organization and cooperation so that the more drastic measures can be postponed. What do you think about it, fellows? — EDITOR.

FOR the past several years there has been article upon article printed in QST about the proper and improper methods of operating an amateur station, especially as regards calling "CQ," broad sloppy notes and holding one's key down for minutes at a time, not to mention the many other thoughtless or deliberate discourtesies of which so many amateurs are at one time or another guilty.

Today we seem to be in as bad, if not in worse, disorder than ever before. One has only to listen for a short time on any of our so-called "international" day or night bands to be convinced of this fact.

Since August of last year, I have been attempting to keep various DX sleds, especially with Australia during the morning hours, and since January 1st, when VK stations moved within our new band limits, it has been all but impossible to hear anyone outside the country, due, about ninety percent, to the tendency of so many W operators to the practice of blotting "CQ" or "CQ-DX" (incidentally

blotting out the only DX which could otherwise be heard) and the chumps who are forever adjusting their transmitters, usually with a book on the key and a note like a saw-mill.

If the above named pests were only restricted in their activities, it would become possible to hear and work these DX stations without serious difficulty, but under present conditions, it is next to impossible. No amount of receiver construction will or can overcome the handicap that these fellows impose on their brother "hams" by their thoughtlessness or indifference.

Surely it will not be long before it will become a punishable offense to call "CQ" from this country after one hour prior to sunset and for at least one hour after sunrise. If these bands are international bands, why clutter the air with such trash and make international QSO impossible? There can be plenty of inter-U. S. A. QSO during daylight hours if 40 and 20 meters is to be used and the traffic handler still has the 80 meter band for this work after dark.

It would seem that even the most dense among U. S. A.

* W9CKQ, Route 1, Box 10, Fort Madison, Iowa.

amateurs would have long since realized that foreign amateurs do not listen for "CQ's" from this country, but call *their own* "CQ" and listen for replies. Doesn't it stand to reason that this is the most sensible procedure for them? Put yourself in the foreigner's place. Why call any one particular W station (unless on sked) when a CQ-W will bring forth scores upon scores of replies?

If these fellows who crave "DX" so badly as to make that same impossible for all of us would desist and listen for DX and then call the other fellow, what a heaven these bands of ours would become, in comparison to the present conditions.

I am in receipt of a letter from ZLIFW in which he says: "The QRM question down this way is not so acute as we first thought it would be. Only occasionally am I troubled with QRM from N. Z. stations. You chaps over there blot out all DX and also blot out one another. There's not much of the long-winded CQing here. It's been cut down a lot lately."

How about it, fellows? Let's pull for legislation that will exclude such sloppy operating methods from our "DX" bands. It should be a punishable offense to call "CQ" or "Test" from this country during the times these bands are considered as being *International*.

ARMY AMATEUR NOTES

We are pleased to announce that Lawrence J. Dunn, W2CLA, former Director of the A.R.R.L. for the Hudson Division, has been commissioned Chief Amateur Radio Aide to the Chief Signal Officer of the Signal Corps of the United States Army.

SEVENTH CORPS AREA: W9ABK is the N.C.S. with W9BCT for alternate.

SECOND CORPS AREA: David Talley, W2PF, has been appointed Radio Aide to the Signal Officer of this Corps Area. In effect this is a continuation of Mr. Talley's

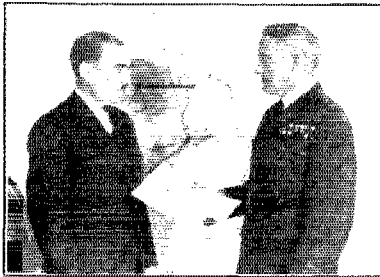

W2CLA RECEIVES HIS APPOINTMENT

former duties in the old scheme of affiliation, and we are pleased to learn of his retention in the former capacity, which he has filled so well in the past.

Western New York Net: WSAKH is acting as N.C.S. in

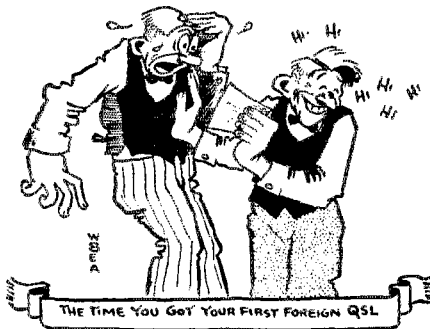

place of W8DME at present. W8BFG and W8BHC are continued as the active stations in this net.

Eastern New York Net: On account of business reasons W2KR, N.C.S., has been unable to keep all schedules during the past month, and W2BPQ and W2ANV have acted as N.C.S. during the schedules.

New Jersey Net: W3ATJ and W3OH didn't miss a single schedule during the month. W2AT and W3ZI were active, also. W2AOS, the N.C.S., installed a new "high C" Hartley. W3MI and W3ASG are new Army Amateur stations in the New Jersey State Net.

W2SC, the Corps Area Net Control Station located on Bedloe's Island in New York Harbor, is at the present time temporarily off the air because of rebuilding operations. In the very near future the station will be back on the air with the usual pep.

Official Broadcasting Stations

CHANGES AND ADDITIONS
(Local Standard Time)

W4ACC, Mon., Sat., 12:30 and 6:30 p.m.; W4AEF (7135 kc.), Mon., Wed., Sat., 3 p.m.; Tues., Sat. (14,300 kc.), 3:30 and 7:30 p.m.; W6CHA (7000-kc. band), Tues., Thurs., 5 p.m.

ELECTION NOTES

To all A.R.R.L. Members residing in the Sections listed below:

(The list gives the Sections, closing date for receipt of nominating petitions for Section Manager, the name of the present incumbent and the date of expiration of his term of office.) This notice supersedes previous notices.

In cases where no valid nominating petitions have been received from A.R.R.L. members residing in the different Sections in response to our previous notices, the closing dates for receipt of nominating petitions are set ahead to the dates given herewith. In the absence of nominating petitions from Members of a Section, the present incumbent continues to hold his official position and carry on the work of the Section subject, of course, to the filing of proper nominating petitions and the holding of an election by ballot or as may be necessary. Petitions must be in Hartford on or before noon of the dates specified, all of which are 1929.

Section	Closing date	Present SCM	Present term of office ends
Western N. Y.	July 15	C. S. Taylor	July 1, 1928
Nevada	July 15	C. B. Newcombe	Sept. 15, 1928
Philippines	June 15	M. I. Felizardo (acting)	Jan. 3, 1929
Virginia	July 15	J. F. Wohlford	Dec. 2, 1928
Arizona	July 15	D. B. Lamb	Jan. 3, 1929
San Diego	July 15	G. A. Sears	Feb. 2, 1929
Eastern Pa.	July 15	J. B. Morgan (resigned)	Mar. 7, 1930
Md.-Del.-D. of C.	July 15	H. H. Layton (resigned)	Jan. 7, 1930

Due to the resignation of Mr. J. B. Morgan, W3QP, in the Eastern Pa. Section of the Atlantic Division and of Mr. H. H. Layton, W3AIS, in the Maryland-Delaware-District of Columbia Section of the Atlantic Division, effective at once, nominating petitions are hereby solicited for the office of Section Communications Manager in these sections and the closing dates for receipt of nominations at A.R.R.L. Headquarters in Hartford are herewith specified as noon, July 15, 1929.

CANADA

Nominating petitions for Section Managers in Canada should be addressed to Canadian General Manager A. H. K. Russell, VE9AL, 5 Mail Building, Toronto, Ontario. To be valid, petitions must be filed with him on or before the closing dates named.

British Columbia July 15, 1929 E. S. Brooks Dec. 2, 1928
Saskatchewan July 15, 1929 W. J. Pickering Dec. 2, 1928

To all A.R.R.L. Members residing in the Sections listed:

1. You are hereby notified that an election for an A.R.R.L. Section Communications Manager, for the next two year term of office is about to be held in each of these

Sections in accordance with the provisions of By-laws, 5, 6, 7 and 8.

2. The elections will take place in the different Sections immediately after the closing date for receipt of nominating petitions as given opposite the different Sections. The Ballots mailed from Headquarters will list the names of all eligible candidates nominated for the position by A.R.R.L. members residing in the Sections concerned.

3. Nominating petitions from the Sections named are hereby solicited. Five or more A.R.R.L. members residing in any Section have the privilege of nominating any member of the League in their Section as candidate for Section Manager. The following form for nomination is suggested.

(Place and date)

Communications Manager, A.R.R.L.
1711 Park St., Hartford, Conn.

We, the undersigned members of the A.R.R.L. residing in the Section of the Division hereby nominate as candidate for Section Communications Manager for this Section for the next two-year term of office.

(Five or more signatures of A.R.R.L. members are required.)

The candidate and five or more signers must be League members in good standing or the petition will be thrown out as invalid. The complete name, address, and station call of the candidate should be included. All such petitions must be filed at the headquarters office of the League in Hartford, Conn., by noon of the closing date given for receipt of nominating petitions. There is no limit on the number of petitions that may be filed, but no member shall sign more than one such petition.

4. Members are urged to take initiative immediately, filing petitions for the officials of each Section listed above. This is your opportunity to put the man of your choice in office to carry on the work of the organization in your Section.

— F. E. Handy, Communications Manager.

ELECTION RESULTS

Valid petitions nominating a single candidate as Section Manager were filed in a number of Sections on or before the closing dates that had been announced for receipt of such petitions. As provided by our Constitution and By-laws, when but one candidate is named in one or more valid nominating petitions, this candidate shall be declared elected. Accordingly, election certificates have been mailed to the following officials:

Section	Address	Two-year term begins
Oregon	Wilbur S. Claypool, W7UN, 943 E. 30th St., S. E., Portland	June 2, 1929
Sacramento Valley	Everest Davies, W6DON, 1234 J St., Sacramento, Calif.	May 6, 1929

In the Main Section of the New England Division, Mr. Harold G. Riley, W1AUR, Mr. John Singleton, W1CDX, and Mr. Grover C. Brown, W1AQL, were nominated. Mr. Singleton and Mr. Brown received 17 votes and Mr. Riley, 9. Therefore, another election must be held enabling the Section to choose between the two candidates, who are tied. Ballots are being mailed at the present time.

In the Los Angeles Section of the Pacific Division, Mr. D. C. Wallace, W6AM, 279 Molino Ave., Long Beach, Calif., and Mr. Melvin S. Wood, W6AVJ-W6DKY, Box 278, Gardena, Calif., were nominated. Election results: Mr. Wallace, 109; Mr. Wood, 69. Mr. Wallace, therefore, has been declared elected, his term of office beginning April 29, 1929.

W7BB of Seattle reports working AC5GO on about 7025 kc. Many will remember this call as being that of old Canadian 5GO, Earl Chang of Vancouver. His present location is Shanghai, and his signal may be heard on the above frequency with an ICW note. W7BB is planning to keep a schedule with him.

BRASS POUNDERS' LEAGUE

Call	Orig.	Del.	Rel.	Total
W1MK	100	198	760	1038
W4AEF	58	25	642	725
K1HR	220	114	378	712
W4ACC	20	11	614	645
W6AKW	30	4	518	552
W9FLG	104	104	330	538
W6EEO	82	256	186	524
W6AD	84	201	236	521
W6ADD	500	—	—	500
W3ZF	7	85	352	444
W9ESL	235	67	106	408
W2SC	38	67	296	401
W1CQ	57	11	308	376
W9DLL	22	20	296	338
W6AVJ	201	33	98	332
KDV5	273	49	4	326
W9COS	83	160	82	325
W6DKV	221	30	70	321
W6CIH	32	14	262	308
W6IP	68	71	162	301
W1AQD	75	34	190	299
W5AQY	169	59	62	290
W6UJ	91	142	24	257
W2BFQ	41	34	176	251
W9ERU	10	41	192	243
W1CGX	22	21	186	229
W6CHA	41	30	156	227
W2BGO	74	28	124	226
W9FS	7	5	214	226
W9DXZ	23	75	128	226
W1ACH	58	54	110	222
W1AUS	21	32	168	221
W8CMB	12	25	183	220
W5WF	12	15	190	217
W9BCA	15	41	159	215
W6DWS	45	17	131	213
W1AUR	17	15	181	213
W8CNO	32	22	158	212
W6BTX-6E1W	8	18	185	211
W4AO	100	40	70	210
W9GHI	57	32	117	206
W8GZ	8	14	184	206
W4RB	131	62	12	205
W6ETA	82	12	110	204
W6DON	26	14	172	202
W6ALX	15	52	110	177
W6EH	45	63	66	174
W6AMM	70	85	6	161
W4AHQ	39	67	52	158
W9LN	62	51	42	155
W4IE	35	52	67	154
W6BVY	62	92	—	154
W1ACA	20	60	28	150
W6ERK	57	55	26	138
W8BMJ	24	51	54	129
W5ASM	36	75	16	127
W3AKB	13	74	36	123
W6BCN	36	81	3	120
W8DSP	26	50	42	118
W4AII	22	57	12	113
W4AGY	23	52	36	111
W3ALF	6	73	30	109
W1KY	20	60	28	108
W6BY	—	64	44	108
W8OA	51	52	4	107
W2QU	38	67	—	105
W6HM	22	66	—	88
W1KH	22	57	4	83

The several amateur stations responsible for the best traffic work — the ones that are "setting the pace" in worthwhile traffic handling — are listed right up near the top of our B.P.L., the figures giving the exact standing of each station accurately.

All these stations appearing in the Brass Pounders' League are noted for their consistent schedule-keeping and dependable message-handling work in amateur radio. Special credit should be given to the following stations (in the order listed) responsible for over one hundred deliveries in the message month: W6EEO, W6AD, W1MK, W9COS, W6UJ, K1HR, W9FLG.

Deliveries count! A total of 200 or more bona fide messages handled and counted in accordance with A.R.R.L. practice, or just 50 or more deliveries will put you in line for a place in the B.P.L. Why not make more schedules with the reliable stations you hear and take steps to handle the traffic that will qualify you for B.P.L. membership also!

High Grade Stations — High Quality Signals

EACH month Section Managers and Route Managers select the outstanding stations which are considered the "best" consistently operated stations in each band. Those having the clearest of notes, those sharpest tuning, and the steadiest signals are reported for QST mention.

Really good signals with the requisite sharpness, steadiness, and clarity of tone which constitute our present-day standards of perfection are not too numerous if we may judge from all reports. To "make" our list it is necessary that the signals be heard *several different times* and if possible reported from *more than one source* as proof of the *consistency* of the station and its *regular use* of a good signal. Of course stations with perfectly good signals must do a certain amount of operating to be heard and reported. Our list thus credits both *outstandingly good signals* and consistency or reliability. No stations with choppers or uncalled-for broadness can qualify, and the attention of observers has been called to this fact so that even the prettiest of signals will not be reported if guilty of being broad and inconsiderate of others.

Operators of stations listed in our reports consistently month after month should be well satisfied with their performance and for good reason. Our column will grow, too, especially if you help your SCM and RM in deciding on their recommendations to QST by submitting small lists of the outstandingly good signals and reliable consistent operators that you hear. Other stations not in our present list will no doubt be able to qualify shortly. Separate reports from each Section in the U. S. A. and Canada will place more emphasis on good station PERFORMANCE — less emphasis on a small DX record accomplished perhaps with brute power and wabby signals. Since our reports come from all over the country they are equally fair to all station owners. This month our list is too long to permit publication of reports from each of the twenty-four Sections contributing to the success of this column. From all the reports received we have compiled an alphabetical summary which credits the stations reported more than once by separate mention. The future of our column depends both on your cooperation in submitting accurate reports and on our new space requirements for this portion of QST. Comments on how you would prefer to see the reports modified to do the greatest good would be appreciated. Separate lists should be turned in for each different amateur band. Detailed lists of high-quality signals and well-operated stations working on the several amateur bands follow:

Reported by five or more observers:

(3500 kc.) W1MK, W2SC.

(7000 kc.) W1MK.

Reported by four observers:

(3500 kc.) W8ANX, W8EB, W8UK, W9APG, W9DLD, W9DSC, W9DXZ.

(7000 kc.) W9CVN.

Reported by three observers:

(3500 kc.) W3SN, W8ZZ, W9CYQ.

(7000 kc.) W3ANH, W4MI, W7EK, W8CSS, W8LT, W9ARA, KFRS.

Reported by two observers:

(3500 kc.) W1KL, W3HL, W3ZF, W8WO, W8XE, W9COS, W9EK, W9FYC, W9YL.

(7000 kc.) W4LL, W5AAK, W5JD, W5QJ, W7ACY, W8BEK, W8CEX, W8DAQ, W8FZ, W8GZ, W9CET, W9CTW, W9DXP, W9EGU, W9FQS.

(14,000 kc.) W6UF.

Reported from one source:

(3500 kc.) W1ACH, W1AFD, W1ALE, W1AQD, W1AQL, W1ASD, W1ATJ, W1ATO, W1AUR, W1RIG, W1BST, W1CGR, W1IP, W1IX, W1TA, W1UN, W1WV, W2AIZ, W2ANG, W2AOR, W3AQR, W3BO, W4ACK, W4AEO, W4AII, W4AJH, W4HJ, W4JO, W4PM, W4SE, W8ARC, W8AVK, W8RKN, W8RYN, W8CDC, W8CEP, W8UCA, W8CMP, W8CNO, W8CRL, W8CVQ, W8DAQ, W8DED, W8DKX, W8DME, W8HB, W8NU, W8PY, W9AZD, W9AZR, W9BBT, W9BKJ, W9BZO, W9CWG,

W9DCD, W9DVR, W9DVS, W9DEH, W9EL, W9EXN, W9FAG, W9FHV, W9GBF, W9GCP, W9IV.

(7000 kc.) W1ACP, W1AXX, W1BDI, W1SZ, W1WV, W2ALG, W2AOL, W2BLX, W2FL, W2FM, W2RS, W2UK, W3AJT, W3AWS, W3CKL, W4ACL, W4ACK, W4ADF, W4ADN, W4AFJ, W4AEO, W4AEW, W4AGG, W4AII, W4AIW, W4AJM, W4ARQ, W4CZ, W4EL, W4JL, W4LK, W4LL, W4MX, W4NF, W4PF, W4PK, W4PP, W4RB, W4SL, W4SP, W4TO, W4VB, W4WN, W4ZC, W4ZP, W4ZZC, W5ACH, W5AFX, W5AHE, W5APG, W5ASM, W5BBX, W5BCZ, W5BF, W5BQ, W5EB, W5PG, W5RD, W6AM, W6AMM, W6ATU, W6BLI, W6BTX, W6BYB, W6CEK, W6CYQ, K6CLJ, W6CUH, W6DCA, W6DFS, W6DPF, W6DPR, W6DWH, W6DYE, W6EAR, W6EAU, W6EHL, W6EMG, W6EPC, W6EQA, W6HB, W6RE, W6SC, W7AAT, W7ALJ, W7ALK, W7AIY, W7HR, W7TS, W7YA, W8ALU, W8ANH, W8APN, W8BAU, W8BTI, W8CAU, W8CFT, W8CKL, W8CLQ, W8CRO, W8DIL, W8NU, W8VS, W8XE, W9ACU, W9ACZ, W9AMA, W9AYU, W9BG, W9BPM, W9BRC, W9BTG, W9BZO, W9CGA, W9CIG, W9COS, W9CXX, W9DBJ, W9DEF, W9DGR, W9DNC, W9DND, W9DWW, W9EHO, W9EK, W9ELL, W9ERM, W9EZO, W9FTY, W9FYY, W9GAC, W9GFT, W9GHY, W9GTY, W9GVC, W9KDL, W9OT, W9SN, W9UW, VE2AP, VE3JK, VE4GK, VE6CP, VE6KD, ZL4AE, ON4EA, EA862, K4AAN, KDV5, W8Q.

(14,000 kc.) W1ACK, W1AEF, W1ALB, W1AQD, W1BKR, W1BOD, W1CMX, W1ZD, W2DAB, W2FL, W3ATJ, W4ACS, W4AEF, W4AII, W4UW, W8OF, W9ASL, W9BPM, W9DGR, W9DSC, VE1BR, VE1BY, F8AAP, F8JF, F8YZP.

Best quality phones (good modulation, low degree of frequency modulation):

W1BQS, W8AYL, W8LT, W8RD, W8WO, W9FKE.

Well operated stations: W1BIG, W1IP, W1X, W1KL, W1LM, W1TA, W1UE, W1UN, W2ANG, W8AKE, W8DAQ, W8FZ, W8GZ, W8HB, W8UK, W8VS, W9BRC, W9CYQ, W9DSC, W9DXZ.

EXPEDITIONS — WIDC

Ffoulkes of W4LK is a radioman on the yacht *Abacena* now on an extended cruise through the West Indies. It is quite possible that the *Abacena* will make a trip around the world in the near future. The *Abacena* is an auxiliary schooner carrying high frequency radio equipment and licensed as a "limited commercial" on the following frequencies under the call signal WIDC: 12,340, 8230, 5525, 3436, 500 and 425 kc. At present the 8230-kc. frequency is the main working frequency. WIDC uses a 50-watt T. P. T. G. transmitter with an 852 along for a spare, power being obtained from a 32-1000-volt dynamotor. Operator Ffoulkes says that nowadays it is hard to raise amateur stations working in our 7000-7300-kc. band as they listen on 8000 kc. less frequently. The operator of the yacht *Ripple* (KFLF) says the same thing. There are some nice (and very worthwhile) contacts waiting for those amateurs who do listen on 8000 kc. or thereabouts. That's where a bunch of limited commercials and expeditions — all needing contact with amateurs' stations — work. Let's help them out with their traffic and roll up some good QSO's with the yachts and expeditions wherever they may be.

The University of Michigan — Greenland Expedition (nx1XL) — has almost daily contact with W1CKP, Mr. G. H. Pinney, South Manchester, Conn. nx1XL has also worked WFAT down at the other polar region.

On April 1st Koehler of W9BEU contacted with Byrd's base WFA, handling some traffic for St. Louis. The party receiving one message had to be convinced the whole matter was not an April Fool joke being played on him. W3KJ reported copying a CQ from WFAT, the *City of New York*, at 11:55 p. m., Sunday, April 20, on the 13th of April, W2AG worked "gl" at WFAT on 14,000 kc., the operator advising him that the Byrd Expedition will work near that frequency quite often in the future. Sgt. Oswald of GX9-W4GH also heard WFAT and WFBT both on 12,500 kc. (24-meters) at 11 p. m. CST March 24th. W6CTP reports that WFA comes

in almost any night one cares to listen (on 9000 kc.) between 9 and 11 p. m. PST, and that many times WFA is easily copied there when WHD is reported ND. W2BFF was QSO WFBT some time ago when the expedition ship was located in the Bay of Wales. As conditions were favorable some traffic was handled for the expedition.

The All-American Lyric Malaysian Expedition is now en route to the capital of Dutch Borneo, due there about June 1st. This expedition will visit remote places in Borneo. One of the objectives of the expedition will be to conduct research in tropical and equatorial radio problems. A station will be installed at the field base, call signal and frequency to be announced later.

Daily observations and measurements on signal strength of certain commercial and amateur stations over a wide frequency range will be taken at regular intervals for a year. Weather conditions over the great circle route and at transmitting and receiving stations will be compiled. Studies of general tropical conditions, fading, skip-distance, Heaviside layer height, and transmissions over the North Polar cap (which happens to lie along the great circle route between the East Coast of the U. S. A. and Borneo) will all be studied as thoroughly as possible.

We are informed that a silk flag of the American Radio Relay League will be made by the wife of the anthropologist with the expedition, and it is planned to carry this far into the jungles of Borneo and set it up at the remote places visited.

W1MK

A.R.R.L. Headquarters' Station W1MK operates on frequencies of 3575 kc. and 7150 kc. Robert B. Parmenter, "RP," is the chief operator; his list is familiar to most of the amateur fraternity. Occasionally other members of the Headquarters' staff operate at W1MK. Their personal signs may be found in the QRA Section of QST.

Throughout the following schedules Eastern Standard Time will be used.

OFFICIAL AND SPECIAL BROADCASTS are sent simultaneously on 3575 kc. and 7150 kc. at the following times:

- 8:00 p.m.: Sun., Mon., Tues., Thurs., and Fri.
- 10:00 p.m.: Mon. and Fri.
- 12:00 p.m. (midnight): Sun., Tues., and Thurs.

GENERAL OPERATION periods have been arranged to allow every one a chance to communicate with A.R.R.L. Headquarters. These general periods have been arranged so that they usually follow an *official broadcast*. They are listed under the two headings of 3500 kc. and 7000 kc.; to indicate whether the watch is devoted to listening on the 80-meter band or to the 40-meter band.

3500 kc.:

8:10 p.m. to 9:00 p.m. on Sun., Mon., Tues., Thurs., and Fri.

10:00 p.m. to 11:00 p.m. on Tues. and Thurs. (No OBC sent before these periods.)

12:00 p.m. to 1:00 a.m. (or later) on Sunday night (Monday morning.)

7000 kc.:

10:10 p.m. to 11:00 p.m. on Sun., Mon., and Fri.

12:00 p.m. to 1:00 a.m. on the following *nights* (actually

on the morning of the day following): Mon., Tues., Thurs., and Fri. (*Only* on Tues. and Thurs. does the OBC precede these periods.)

SCHEDULES are kept with the following listed stations, through any of which traffic will travel expediently to A.R.R.L. Headquarters. The frequency included within parentheses indicates the band in which each individual station keeps the schedule with W1MK:

- W1ACH, Brookline, Mass. (3500): Sun. and Thurs.
- W1KY, Cambridge, Mass. (3500): Mon. and Fri.
- W1VB, Newtown, Conn. (3500): Tues. and Fri.
- W2A00, Brooklyn, N. Y. (3500): Mon. and Tues.
- W2JF, Jersey City, N. J. (3500): Sun., Thurs., and Fri.
- NJ2PA, Port Antonio, Jamaica (7000): Sun., Mon., and Fri.
- W3ZS, St. David's, Pa. (3500): Mon. and Thurs.
- W4AEF, Lakeland, Fla. (7000): Sun., Wed., and Fri.
- W6AKW, Lancaster, Calif. (7000): Mon. and Fri.
- W6CIS, San Francisco, Calif. (7000): Tues. and Sat.
- W8BYN, Columbus, Ohio (3500): Mon., Tues., and Fri.
- W8DSP, Syracuse, N. Y. (3500): Tues. and Thurs.
- W8ZZ, Detroit, Mich. (3500): Sun. and Thurs.
- W9APY, Berwyn, Ill. (3500): Tues.
- W9ERU, Rockford, Ill. (7000): Sun. and Fri.
- W90X, Louisville, Ky. (3500): Sun. and Thurs.
- VE9AL, Toronto, Ont. (3500): Tues. and Fri.
- NNCX, Puerto Cabezas, Nicaragua (7000): Mon.

There are a number of old stand-bys that have been canceled temporarily and which will be resumed at a later date. Stations among this list are W1BIG, W2SC, W3ZF, W4RM, W8ARX, and WBSB.

TRAFFIC BRIEFS

W4IE reports that KFLF, the *Yacht Ripple*, has started on a month's trip from Sarasota, Florida, to the West Indies. Upon return the *Ripple* will leave on another trip to Maine for the summer, and after that may take a jaunt down to South America. KFLF uses a frequency of 8330 kc. and keeps several daily schedules with W4IE.

W2TY writes us from Manizales, Colombia, and says that he has found QST down there, 'way up in the Colombian Andes. W2TY will be remembered for his work with W8CFR in keeping in touch with GMD of the Dyott Expedition in South America.

AU7AA on 6785 kc. is a station giving the QRA of Wiktor Chionaki Telefonnia 5 Baku Azerbaijan, Asia. W4AEF worked him on March 7th and believes that his QSO is the first one from the United States with Azerbaijan.

All Philippine Islands amateur station calls now are prefixed with the letter K.

Recent floods in Alabama and Florida have called forth the cooperation of amateur radio once more. On the 15th of March the Chamber of Commerce in Pensacola, Florida, called on Ensign Francis Wm. Taylor, W4HQ, Commander of Section 2 of the Communication Reserves of the Eighth Naval District, with the news that communication was gradually being cut off between Pensacola and other cities. The cooperation of three Naval Reservists, W4VR, W4TW, and W4AKF, were secured. W4VR and W4TW served as operators on Coast Guard relief boats which worked in the flooded areas, and W4AKF stayed home and kept the ether busy. W4HQ also secured the cooperation of NAB (Pensacola) and NDZ (New Orleans). Excellent contact was maintained throughout the period of interrupted communication from Pensacola. Up in Alabama, W4AAQ was on the air and worked W4AKF in Pensacola. W4LT did his work right in the flood water by paddling his canoe through the raging waters of the Choctawhatchee River to rescue six persons marooned in a cabin.

 Entries for the A.R.R.C. Cup should be sent to Chairman D. C. Wallace, W6AM. This contest, with award to the best Sixth District amateur station, is sponsored by the



Amateur Radio Research Club of California. Complete rules were published in the March issue of the *Oscillator*, and may be obtained by addressing W6AVJ. Entries must be received by August 1, 1929, for the contest for the year of July 1, 1928, to June 30, 1929. Requisites for eligibility are, roughly, a well-built and efficiently operated amateur station. Unless at least twenty-five entries are received, the contest will be postponed until next year.

We got a card the other day which said: "Why do amateurs persist in using QSR instead of QSP? I worked W9 --- the other day and he asked me to QSR. I said I didn't (which was perfectly true --- no distress call had been received at my station), and then he got sore and didn't come back."

The amateurs of Eugene, Oregon, have reduced local QRM appreciably through an agreement that all in that city shall operate on one end of the frequency band in

question --- which, in this case, happens to be the 7000 kc band. FB, boys, that's coöperation!!

W7BB of Seattle reports that the first news of the finding of Anderson, the Australian flyer who was lost while searching for the *Southern Cross*, came via VK2OW, and beat the time of the Associated Press cable by twelve hours or more.

What would the guy with broad A.C. and the guy with fluttering D.C. do if nobody would answer him? . . . Yup --- you guessed it --- he wouldn't work anybody and therefore would think that something was wrong with his set. Perhaps then he would get busy and work on it until he had taken the broadness or the fluttering-ness out of his signal. The Twin City Radio Club of New Haven, Conn., and the Associated Radio Operators of Denver have recognized the forcefulness of this sort of a solution to the problem of bad signals, and have each passed resolutions that their members will not work stations whose signals are of the "broad A.C." or "fluttering D.C." type. FB, New Haven, and Denver.

Divisional Reports

ATLANTIC DIVISION

MARYLAND-DELAWARE-DIST. OF COLUMBIA --- SCM, H. H. Layton, W3AIS --- This will be my last report as Section Manager, as my professional duties make it necessary for me to resign. It has been a great pleasure to me during my term working with the gang. I have turned everything over to Mr. Forrest Calhoun, W3BBW, who will complete my unexpired time. Give him your support, fellows, and make this Section stand out.

Maryland: W3APX received Intercollegiate Boxing results from W8XE. W3BBW is rebuilding. W3MH had visitors.

Dist. of Columbia: W3ALF had final exams. W3BWT is rebuilding.

Delaware: W3AHJ is the call of the Wilmington Unit Naval Reserve. W3AIS is active. W3AJH pounds brass at W3AHJ with W3WJ. W3ALQ is QSO phones on 3570.

Traffic: Md: W3APX 11, W3MH 1. Del: W3AHJ 8, W3AIS 7. D. of C.: W3ALF 109, W3BWT 65.

SOUTHERN NEW JERSEY --- SCM, M. J. Lotysh, W3CFG --- W3CFG leads with a small total and some good DX. W3BVG is next with fair total gathered on 7000 kc, along with some DX. W3ARR has improved his total. W3ATP promises better totals. W3RWJ is studying. W3AR has disappointing total. W3ATP had xmitter trouble. W3ARC moved to Phila. W3SJ has gone to sea and W3AOC leaves Princeton in June. W3BEI is no longer an ORS. The SCM requests every active "3" in the state to report monthly whether he holds an ORS appointment or not.

Traffic: W3CFG 52, W3BVG 42, W3ARR 33, W3ATJ 14, W3BWJ 8, W3ATP 5, W3ARN 2.

EASTERN PENNSYLVANIA --- SCM, J. B. Morgan, II, W3QP --- W3ZF's total is *very low* (!), as he is moving to new location. Good luck, Don and Pat. W8DHT QRM'd by school. W8AWO is installing a new set. W3AKB is turning into hostess for all transient hams (Mr. Armour take note). Drop in there and see a good rig, fellows. W8CWO made his score in only one week's working. A new institution, the Scranton Amateur Radio Club, has hung out its shingle and should have the support of you fellows in that district. W3CDS says he's been sick again. W3MC has been picking 'em off the west coast with a UX210. W3AHZ has some skeds working well and hopes to have an 852 going soon. W3NF is certainly piling up the traffic. Congrats, Ed. W8VD is gathering in his, too, with success. Due to increased business activity and less time available, this is the last report you will have from me as your SCM.

Beginning next month, send your reports to Don Lusk, W3ZF, 3622 15th St., Phila., Pa., who has accepted appointment as Acting Section Manager until another election has been held. It has been a pleasure to work for and with you fellows and I appreciate your help and suggestions and regret very much that it is necessary to withdraw from the scene of action. Give Don and his successor the same confidence

and backing and keep the section in the position you have put it in.

Traffic: W3ZF 444, W3NF 161, W3AKB 123, W8VD 45, W8CWO 34, W3AHZ32, W3CDS 16, W8AWO 9, W3MC 8, W8DHT 5.

WESTERN NEW YORK --- SCM, C. S. Taylor, W8PJ --- W8ABX is working on 56 mc. W8BHK and W8AFG have many schedules. W8AID and W8AHC worked a raft of foreigners. W8AK, W8AXK and W8BFG are handling traffic. W8BFP has moved into a new shack. W8BLP is at school. W8HJO and W8BLV have fine traffic reports. W8BOX, W8BMJ and W8BUJ are back again. W8CYG and W8BUP worked some good DX. W8BWU and W8OA are both on. W8CNX, W8CDB, W8CMW, W8DII and W8CKC handled some traffic. W8CSW visited W9DED-W9FBJ. W8FC, W8CVJ and W8DDL are on for traffic. W8DME has become a crystal expert. W8DQP has joined the Army net. W8DSP has some good schedules. W8KS missed the Rochester get-together.

The clubs of Buffalo and Rochester held a combined hamfest on the 13th of April in Rochester. Sixty-six hams sat down to the banquet at Hotel Seneca, and during the day some very fine talks were given by Mr. Truscott, of GE, by Mr. Gimmell, the RI, by Mr. Bauman, Pres. of the Finger Lakes club, Mr. Heiser of W8DME, Mr. Schraeder of W8ADG, Mr. Miller of W8CTK, and by Mr. Hobbs, ZLIAR. The SCM wishes to thank W8AE and W8ALY for their fine work in arranging for this meeting.

Traffic: W8ABX 2, W8AFG 2, W8AHC 24, W8AK 4, W8ARK 75, W8BRP 14, W8BCM 53, W8BFG 14, W8BHK 99, W8BJO 59, W8BLV 48, W8BMJ 129, W8BOX 22, W8BUP 3, W8BWU 54, W8CDB 113, W8CKC 9, W8CMW 52, W8CNX 82, W8CSW 16, W8CVJ 15, W8CYG 25, W8DDL 60, W8DII 44, W8DME 31, W8DQP 48, W8DSP 118, W8FC 10, W8KS 2, W8OA 107.

WESTERN PENNSYLVANIA --- SCM, A. W. McAuly, W8CEO --- W8CHC again leads the gang in number of messages with W8XE running a fair second. W8CFR is still after PY traffic. W8CEO has two ranges of the three range receiver working. W8DHW came through with a fair total. W8CNZ reports that W8AT is QSO hams on 14 mc. about midnight. W8ARC is busy winding RF chokes a la W8CMP. W8DKS is building a new Zepp. W8AGQ was QSO Mr. Hebert at W8CMP. W8ACU has a sked with the SCM for Pittsburgh delivery. W8CUG handled a nice bit of traffic. W8CMP is still battling them out. W8DLG is building a fine station. W8BVG is building a row boat. W8GU was a visitor in Erie. W8BBN have the radio class in the YMCA.

The radio inspector is coming April 15th to Erie and we expect to see the list of calls go up as several club members contemplate on taking the exams. W8CZE is again in New York City. W8DOB cannot get his xmitter perking the way he wants it to.

Seven stations not ORS reported traffic this month. The SCM is glad to get your reports and the traffic figures are watched. The ATA entertained Doc. Woodruff and Treas. Hebert at a banquet this month. About 75 members were present. Angus. W9CYQ, was a visitor also on that night.

Traffic: W8XE 169, W8CFR 56, W8CFO 49, W8DHW 38, W8CZN 17, W8ARC 9, W8DKS 9, W8AGQ 9, W8AGO 9, W8AMU 4, W8CUG 55, W8CMP 32, W8DLG 53, W8APQ 43, W8AVY 19, W8CRA 6, W8DNO 4.

ROANOKE DIVISION

WEST VIRGINIA — SCM, F. D. Reynolds, W8VZ — W8OK has another big tube, W8DPO worked some nice DX. W8DNM is married now. W8ILI, W8AFB, W8DCM, ex-8BKE, W8AEG, W8SV, W8APN, W8CSR, W8CDV, W8SP, W8BPT, and W8VZ all report. W8HD has revamped his outfit and is now operating quite regularly, keeping A-A schedules and handling a bit of traffic. W8CLQ in Mannington continues to handle lots of traffic: if you are looking for a good West Va. contact, hunt him up. He is on 3500 kc. every night with a couple of UX210's. W8ACZ is rebuilding his entire station and will have a MOP-A going before long. Yet it will be on 3500 kc.

Traffic: W8DPO 34, W8ACZ 61, W8HD 3, W8CLQ 70. **VIRGINIA** — SCM, J. F. Wohlford, W3CA — W3EC has rebuilt his transmitter into Colpitts circuit and is getting out in fine shape. W3KR says WFBT traffic has been heavy and does not understand why all the xtal reports when using only a two-fifty in self-excited circuit. Says DX has been good with him. W3FJ claims good DX on several nights connecting with EF8ACJ and VK station. W3AIS has received appointment as Army-Amateur station and has regular sked with W3SN. DX is better with him this month. W3AAJ has been closed up and the new station, W3WS, will be operating soon from same location as WRVA. The Richmond Club seems to be going strong now and has a membership of twenty-five. W3HY expects to build a receiver to take abroad with him this summer. W3BZ reports skeds with W8CMP and W8CRI. W3BDZ has completed his power unit. W3CA has rebuilt transmitter. The SCM and W3BDZ visited W3CKL recently.

Traffic: W3EC 70, W3KR 78, W3FJ 8, W3ALS 38, W3HY 1, W3BZ 9.

NORTH CAROLINA — Report compiled at Headquarters — W4VH leads the whole section with a total that started up within eleven days of operating. FB! W4ZD claims several schedules and comes along for second place this month. W4AEW reports a new radio club. W4TS hauled in a few messages. W4OC still keeps the FQPM schedule. W4AFW and W4TN were on for a few. W4AB expects to be on when vacation comes.

Traffic: W4VH 85, W4ZD 58, W4AEW 41, W4TS 37, W4OC 19, W4AFW 7, W4TN 5.

ROCKY MOUNTAIN DIVISION

COLORADO — SCM, C. R. Stedman, W9CAA — W9CAA is working on all useful frequencies including 28,000 kc. W9DGG has been busy. W9BQO has been on more. W9FUR has school QRM. W9DQV leads the whole section in traffic. W9EAM is on 3500 and 7000 kc. W9CDE uses low power on 7000 kc. W9EAE moved to Clovis, New Mexico. W9CCM is back after a few weeks off the air. W9FXW is still on the air at Boone. W9EBF is getting out good. W9BDY has moved to Greeley. W9CKN is a new ham at Greeley, also. The SCM would appreciate hearing from any other hams in the state who have not been mentioned in reports from this section. Don't be bashful, fellows. A card to W9CAA will do the trick. W9DND is having trouble with his transmitter. W9DQD, W9CSR, W9CDW, W9CCW, and W9DKM all reported.

Traffic: W9CAA 25, W9BQO 20, W9CDE 10, W9EAM 10, W9DQV 33, W9EUR 1, W9DGG 3, W9CND 11, W9CCM 3, W9EBF 2.

UTAH-WYOMING — SCM, Parley N. James, W6BAJ — W6BTX and W6EIV take the honors this month by making the BPL. They are keeping four skeds. W6EKF was very busy at school but handled traffic anyway. At last, W6DXM finished his new transmitter and he is on regularly

now. W6BUV reports by radio. W6RV handled a few with a 301A. W6BAJ has a new mercury arc. W6ATU is with us again with a 210 in a High C circuit. W6DYE was busy. W6DPO has trouble with his receiver.

Traffic: W6BTX and W6EIV 240, W6EKF 61, W6DXM 34, W6BUV 10, W6BVB 7, W6RV 4, W6BAJ 1, W6ATU 1, W6DPO 16.

SOUTHEASTERN DIVISION

ALABAMA — SCM, S. J. Bayne, W4AAQ — W4AJY has been busy at the local broadcast station. W4AX maintains a schedule with nBCY. W4AJY is perking well now. We are sorry to learn that W4AHY has been ill. W4AIY has been experimenting. W4UV has worked all continents. W4AQ and W4AHQ lead the state in traffic, both making the BPL. W4AHQ uses a gas engine to drive his generator. W4TI and W4AIM are on deck. W4LT operates phone on the high band with splendid results. W4AHP has a new Zepp and schedules every day. W4AHR requests those interested in Army-Amateur appointments to write him at once. We have W4MY's first traffic report. W4AJR has received his ORS appointment. W4AAQ is elated over the increased activity in the section.

Traffic: W4AQ 210, W4AHQ 158, W4AAQ 115, W4AHP 101, W4AHR 100, W4AJR 50, W4AX 42, W4TI 31, W4UV 19, W4AJY 24, W4AIM 12, W4MY 9.

FLORIDA — SCM, Harvey Chafin, W4AII — W4AEF has QSO'd Asia for the sixth time in three weeks, and has a fine traffic total. W4ACC's license has expired but seemed not to affect his total. KDV5's total of 326 is being included in Florida's report this time. We hope to have you with us in the future, KDV5. The following stations have applied for ORS appointments: W4CT, W4QV, W4AFU, W4NE, W4AKQ and W4ADB. W4RB sure is handling some traffic with that UX203A. W4IE is keeping a schedule with NNTNIC and is handling most of his traffic for the states. W4AII has a crystal and a 3500 kc. tone set. W4BL reports 28 mc. FB with no static. W4NE worked VK on 14 mc. W4MS is back with a fine traffic total. W4AKF did some good work during the flood. W4YK, W4TW helped by going as operators on the U. S. Coast Guard Cutters. W4MS has a new QRA, 1812 Lakeview Blvd. He is the Florida Route Manager and wants the fellows to arrange several skeds with him. W4UW is back from the sea. W4SD reports via radio. W4AGN and W4IV sit at their keys all day long. W4AKQ and W4AGY are telegraph operators at spare times. W4OZ is keeping a schedule with the yacht *Apple*, KFLF. W4QV is a new ham. W4AFU designs QSL cards. W400 has his OBS schedules at 6:30 p.m. on Monday and Wednesday on 3500 kc. W4ZF has an idea of a chain hook-up. W4PAW, a portable call of W4AII's, will be heard quite a bit this summer. W4SK has worked all U. S. districts. W4ABA is working between Miami and Panama now for the Pan-American airways. W4PAC and W4MW have just bought an airplane together and expect to take us up some day. W4IX is chief operator at the U.S.N.R. at Tampa. W4AEF has just been elected President of the Radio Club at Tampa and W4AFU, secretary and treasurer. The SCM would like very much to hear from all of the clubs in Florida. W4PK, W4GE, W4HZ, W4MF, W4HB, W4DU, W4AFF and W4SY all report. Starting May first, the SCM is offering a very valuable prize to the three stations handling the most traffic. For information, write the SCM.

Traffic: W4AEF 725, W4ACC 645, KDV5 326, W4RB 205, W4IE 154, W4AII 113, W4AGY 111, W4BL 75, W4CT 49, W4NE 43, W4MS 41, W4ADB 35, W4AGN 35, W4JV 29, W4SK 28, W4UW 27, W4BB 25, W4ACK 25, W4SD 24, W4AKQ 18, W4OZ 17, W4QV 12, W4AFU 11, W4OOS, W4ZP 7, W4HY 6, W4PAW 6, W4TK 4, W4OB 3.

GEORGIA-SOUTH CAROLINA-CUBA — Acting SCM, J. G. Cobble, W4RM — W4VP is working DX with a Belgian 500 watter. W4SI works DX. W4KL is married. W4KV leads traffic list. W4OJ will soon be on at Ft. McPherson, Ga. W4ZA is still using xtal. W4AHM is next in traffic with 26 messages. Been QSO France, Mexico and West Indies. W4AZ is experimenting with multiple tuned antenna for receiving. W4RN on 7000 kc. handles 20 messages. W4HW reports 12 messages, and some phone work. W4RM was QSO XF8ZA, St. Helena, 10 messages. Hams in S. C., Ga., Cuba, please mail your reports in to W4RM.

J. G. Cobble, Acting SCM, 1124 Mayland Circle, Atlanta, Ga.

Traffic: W4KV 29, W4AHM 26, W4RN 20, W4HW 12, W4RM 10.

NORTHWESTERN DIVISION

OREGON — SCM, R. H. Wright, W7PP — W7AHV is experimenting with tone. W7WJ has a new receiver. W7IF is working his usual DX. W7AJX is busy. W7GQ says spring has come. W7UN reports 14,000 kc. FB for night transmission. W7ALM has skeds with AC7XOT, W7HN, W7LT, W7UB, W7WY and W7JV. FB, OM. W7WB will be on 3500 and 14,000 kc. using a 204A. W7TU is figuring on high power. W7ED has a 50-watt outfit. W7KH has been rebuilding K7JL. W7IF reports activity increasing in Coos Bay region. W7AIG is on 7000 kc. W7ANW is working on 3500 and 7000 kc. with 231's. W7RR is using a 210. W7AHC is leaving for the north on a cannery job. W7AAR is a new recruit in the ranks of the boiled owl. The amateurs at Eugene have reduced local QRM considerably by all agreeing to remain on the bottom half of 7000 kc.

Traffic: W7ALM 75, W7WR 57, W7ST 49, W7PL 40, W7UN 37, W7WL 35, W7IF 21, W7AMF 18, W7PE 17, W7RR 16, W7AAR 9, W7GQ 7, W7ALE 4, W7ANW 3, W7AIG 2, W7EO 2.

MONTANA — SCM, O. W. Viers, W7AAT — W7HP and W7HT keep daily skeds on 3500 kc. W7DD is increasing power. W7FL has a new vertical rain pipe antenna. W7ZU is playing with television. W7AEM has YL QRM. W7TB and W7DJ are busy. W7EL will have a surprise soon. W7AAT is now net control station for the 9th Corps Area.

Traffic: W7AAT 86, W7HP 82, W7HT 41, W7FL 29, W7DD 26.

WASHINGTON — SCM, Otto Johnson, W7FD — This month marks the departure of many brass-pounders for the "Far North." Activities are still on the increase, from all indications. Many new stations are coming on the air. Tacoma seems the most active city with W7AFO, W7KT, W7NS, W7MX, W7NA, W7APF and W7AIJ on 14 mc. and 7 mc. W7GP is on with the 250-watt xtal control rig and keeps Olympia on the map. W7ACS in Tacoma is QRW work. In Everett we find W7EK, W7PH, W7ACY, W7MW and others on. W7AOG in Bellington is QRW work. W7IU is on in Spokane. Seattle is well represented by W7LZ, W7AG, W7TX, W7VK, W7WG, W7BB and many others who are on regularly. W7OV out in the sticks is doing some good low power work. W7LI up in Port Angeles is on using a new Zepp but seems to get out in spite of the Zepp. (W7LZ, please note.) Hi. W7AF of Decatur is now signing K7AIF in Alaska. W7ALQ of Underwood will also sign a K7 call from Ketchikan for the next year or so. Woodyard of K7HL is heard on and will have lots of non commercial traffic. Ye SCM is planning a change in ORS personnel soon and many new ORS will be appointed. The SCM will also try to arrange for more time for League Communications Department work.

Traffic: W7LZ 83, W7ACY 71, W7KT 47, W7PH 46, W7UI 35, W7TX 27, W7VK 23, W7OV 25, W7WG 18, W7AF 16, W7MW 14, W7AG 14, W7GP 9, W7L 6.

IDAHO — SCM, James L. Young, W7ACN — The new hams seem to be in the majority in Idaho now. We introduce W7AAN and W7FN, both of Boise. W7AEG of Orofino, father of W7HR (this makes a father-and-son station for Idaho), and W7AFE of Parma. Our old friend, ex-W7AFK, has applied for a new license and will be hitting the ether with a new call. W7II and W7HE have been installing a Vitaphone "talkie" outfit. W7YI reports a new Overland coupe and expects to rebuild. W7HR reports a bad case of spring fever, but tops the list anyway. W7ACP is hitting on all cylinders. W7AFE is organizing a radio club at school. Listen, gang, W7ACP suggests an Idaho convention of hams, to be held in the southwestern part of the state. What say, gang? Slip your vote to the new SCM pro tem. W7AIQ is on 7000 and 14,000 kc. and also takes a trick at the local BCL station. KGKX, in Sandpoint, School and the lambing season are keeping W7ACD pretty busy. W7YA is on regularly, and reports W7AAN and W7FN as new hams from the radio class. W7UJ from Eugene and now chief op at Idaho's largest BC station, KIDO, reports that he is

getting on with a MOPA using a 7½ and a 50-watter. W7AKZ and W7HR are active. W7GU is working east just fine. A number of the Nampa High School radio students are building transmitters and will be on as soon as they get licenses. W7ACN has a brand new 7½-watt MOPA with DC power supply.

Now gang, here is some news. W7ABB will be SCM pro tem of Idaho from June until September. His name and address follows: Harold McBirney, W7ABB, 1720 Washington St., Boise, Idaho. The June report will be due to him on June 15th. Let's have every Idaho ham behind him with a good report. The Caldwell troupe of the Idaho National Guard has a bunch of fellows training for radio operators, and no doubt some of them will sprout out with a ham station before we know it. The 9th Corps Area of the Army Amateur Radio Nets under the supervision of the War Department is looking for some good, RELIABLE stations in Idaho and other states to include in their relay nets.

All Idaho station owners interested in A-A work, please communicate with the SCM or with the Ninth Corps Area at the Presidio in San Francisco.

Traffic: W7HR 24, W7YA, 16, W7YI 4, W7AJQ 3, W7ACD 2, W7ACP 1.

PACIFIC DIVISION

HAWAII — SCM, F. L. Fullaway, K6CFQ — An A-A Net has been started between K6CFQ as the NCS and K6EST and K6AEF. Everyone works on 7036 kc. with break-in. It's sure nice to hear those boys working. All stations interested in this work are requested to communicate with the SCM. K6AVL handles the most traffic for the month. Skeds did it. K6CJS has three ops and lots of time. K6CFQ has been keeping skeds with xW7ES aboard the *Vigilant*. K6ENE sends in a good one. K6DJU will be leaving us soon. Aloha to him. K6EST burns out several 210's in a month to keep up his record. K6TDG keeps six skeds — one with WSBS. K6DPG is trying MOPA. K6DB still has his L. A. sked. K6ALM tried shield grid. K6AEF is going to rebuild. K6CLJ rebuilt K6EAT during the Easter vacation. K6ACW and K6EHA reported for the first time.

Traffic: K6AVI 96, K6CJS 78, K6CFQ 59, K6DJU 42, K6ENE 38, K6EST 32, K6DTG 30, K6DPG 18, K6DB 16, K6ACW 13, K6ALM 8, K6AEF 4.

SAN FRANCISCO — SCM, C. F. Bane, W6WB — W6AD leads as usual. His deliveries alone each month run well over 200 messages. Very fine work, Schmidt. W9ERK comes second with a good total. W6AC, W6FK and W6AWA are sufferers from power leaks. W6CHL and W6PW are heard occasionally. W6KJ, W6WB, W6I F and W6CZM did some good DX. W6DSS reports this month and claims new receiver FB. W6BMU and W6DZZ are rebuilding. W6DPR is net control station in this section for the Army-Amateur work. W6DBD has been appointed Radio Aide in S. F. W6CIS says his skeds with WSBS and W1MK are doing very nicely. W6WN, the new RM, says he is very anxious to hear from any of the boys, but particularly those in the northern part of the section. W6DPF contemplates grinding a crystal. W6DZQ reports a nice total this month. W6DYB is troubled by QRM in keeping his schedules. The Associated Radio Amateurs are growing in leaps and bounds, and their membership now runs over thirty members. They welcome correspondence with any other radio clubs. Address same in care of W6WB, who is president. On March 12 the hams in Bolinas combined forces and opened up a new station with the call W6BL. They plan on handling plenty of traffic and have applied for an ORS. Great stuff, men, and I wish you lots of luck.

Traffic: W6AD 521, W6ERK 138, W6CIS 78, W6DZQ 69, W6DYB 63, W6BL 37, W6DPF 25, W6BMU 24, W6DZZ 21, W6WN 19, W6DSS 10, W6AWA 12, W6WB 8.

LOS ANGELES — SCM, D. C. Wallace, W6AM — Five stations make the BPL this month — W6AKW, W6AVJ, W6DKV, W6UJ, W6CHA. W6AKW worked Guam and also kept a good bunch of skeds. W6AVJ handled messages between W9DWN and a girl who had sleeping sickness. Also some messages from Mexican families in the war zone. W6DKV had a science exhibit at high school and his portable station in operation and so had a good number

of originated messages. W6CJ has been working for an old desert rat on a "treasure finder." It seems to work up pretty good after it was balanced up. He also handled Aero Corp. of Calif. traffic for three weeks. W6CHA reports that the West Coast Experimenters Club is going strong now. For dope, write W6CHA. Sey. W6ZBJ was handicapped for about ten days on account of burning hands on gas heater. W6DJJ had a special schedule with W6DON connecting a sick mother with her son. W6CBW is getting QSA4 and five reports from Zeddies and Aussies on a 210. W6EGH has a new QRA in L. A. W6CHT, W6EFA and W6DJI are on 7000. W6ESA and W6TK have Hartley transmitters. FB. W6PT had a schedule with an expedition to Death Valley and learned some very interesting things on skip distance. W6EKE handled messages from his fraternity brothers at the SAE house. W6AM is on as usual. W6CRC, W6ETJ, W6DYL and W6DYJ send in good reports. W6BZR plans on a 3500-ke. phone set. W6ALR rebuilt his transmitter and is sending messages free for customers in company. W6EPC sends in a good report. W6CZO worked 55X. W6MA, W6DZL, W6AXE and W6FKC are keeping good skeds. W6DOW, W6AEC, W6OF and W6DSG send in good reports. W6EPH is going good on traffic. W6APW and W6BJX built screen grid receivers. W6AGR is QRW new job. W6EEB blew his 210. W6DHM burned up his transformer. W6AWY has tried 3500-ke. tone. W6BRO has his new receiver finished — all in copper. W6BYM has moved to Dinuba. W6HS is keeping his regular USDA sked. W6HT has a new 1929 transmitter. W6ASM says that the ARRC will stage the largest banquet ever thought of by the section next October. W6COT has heavy QRM from school. W6CUH built a new receiver for W6DLN. W6CZT, W6DLK, W6BTA, W6DPY, W6HGC report as usual. W6QF reports his transmitter is on 4550 ke, as W6XC. W6DNF is still getting ready for 1929.

The Amateur Radio Research Club of Los Angeles will give the next quarterly banquet just before the Pacific Division convention this fall. The Pasadena Short Wave Club holds good meetings regularly, as well as the other clubs in the section. A new club has been formed at San Bernardino.

Traffic: W6AKW 552, W6AVJ 332, W6DKV 321, W6UJ 257, W6CHA 227, W6ZBJ 192, W6DIJ 108, W6CRW 89, W6DYL 70, W6EGH 60, W6EFA 59, W6DJI 53, W6ESA 48, W6FT 45, W6TK 39, W6EKE 37, W6AM 36, W6DYJ 32, W6ETJ 29, W6BZR 28, W6ALR 24, W6EPC 24, W6CHT 23, W6CZO 22, W6FKC 20, W6AXE 18, W6CRC 18, W6BJX 17, W6OF 17, W6DSG 15, W6EPH 14, W6APW 13, W6AGR 12, W6AEC 11, W6EEB 11, W6DOW 9, W6DZI 8, W6DHM 7, W6AWY 6, W6MA 6, W6BRO 5, W6BYM 5, W6HS 4, W6HT 3, W6LSM 4, W6COT 3, W6CUH 2, W6ZZA 2, W6CZT 2.

SANTA CLARA VALLEY — SCM, F. J. Quement, W6NX — Congratulations, fellows, on the way the reports came in this month. Message handling activity this month places W6AMM, W6BYV, and W6HM in the BPL and with W6JU, W6AME, W6BHY and W6RMW all handling heavy traffic — although not quite enough to make the BPL. With W6AMM, W6BYV and W6HM all on schedule with stations across the Pacific, a large amount of difficult traffic is being cleared. W6HM has an important sked with WSBS and is handling many of their important technical messages, many of which go over 100 words. W6AME with four ops is QRV for traffic as is W6JU, the San Mateo Junior College Station. One of W6JU's skeds is with the YL, W6ETA. Hi. W6BYV with two ops is a reliable west coast contact station. W6BHY is the new president of the SCCARA. W6BMW with a new G. R. wavemeter and a couple of 866s is again on the air. W6BNH has a sked with W6BLT. W6BYH was QRW this month. W6AJZ is back on the air and W6ESW is a new ORS. W6AZS is working on aeriads and reports good contact with VSAB on 14 mc. W6BAX was WAC during one week and W6AAZ is using an 852 on 14 mc. with FB results. W6EBP is putting in an MOPA.

Traffic: W6AMM 161, W6BYV 154, W6JU 116, W6AME 113, W6RYV 108, W6HM 88, W6BHY 65, W6BMW 22, W6BNH 3, W6NX 16, W6BYH 2.

ARIZONA — Acting SCM, Russ Shortman, W6BWS — W6EH leads the state in traffic this month. He is ex-9BCJ of

spark days. He says he gets a big kick out of chewing the rag with his old friends in the midwest. He also keeps W9AMA in touch with his YL, who is living in Phoenix. W6EOF got an appointment to the Army aviation school at Riverside, Calif. W6CDU will have a he-man station on the air one of these days. W6CRA is moving east. W6EFC, a non-ORS, is hitting it off in great shape. W6BJF got hold of 30 telephone condensers and is using them in his filter. He has a fine total this month. W6CCL is headed for Australia. W6BWS is getting a crystal ground up and will have a real note on the air soon. He will be on pretty consistently soon, as he will have no college work to do and has also quit all YLs. Believe it or not. W6DTU reports hearing all continents in one night on 14,000 kc. W6CDY is now an engineer at KGAR. W6EAA reports that the push-pull Hartley is still putting out a nice steady signal, and turns in a nice list of schedules and messages. W6DCQ is building a new shack. W6DIB loaned his apparatus to a broadcast station. W6DIE has a new vibroplex.

Traffic: W6EH 174, W6BJF 106, W6CDY 4, W6DTU 50, W6BWS 79, W6EFC 17, W6EAA 73.

PHILIPPINES — SCM, M. I. Felizardo, KIAU — The report this month is as usual handled by W6EEO via radio: K1HR, now keeps the following schedules, as reported by Capt. A. J. Wehr: K9PB, Zamboanga, P. I., 5:15 p.m. daily; WVN, Tientsin, China, 5:30 p.m. daily; AC8ZW, Shanghai, China, 6:00 p.m. daily; OMITEB, Sumay, Guam, 7:30 p.m. daily; K1RC, Cavite, P. I., 8:00 p.m. daily; AC8AG, Shanghai, China, 9:00 p.m. on Mondays, Wednesdays and Fridays; W6EEO, Williams, Calif., 9:30 p.m. daily. Frequency of K1HR is now 7010 kc.

Traffic: K1HR 712.

EAST BAY — SCM, J. W. Frates, W6CZR — Through the excellent work of W6CTX and the Boy Scout operators under his charge, traffic took a spurt during the past month. W6CTX, who is a scoutmaster besides being an RM, set up a transmitter at the Scout Merit Badge Exposition at the Oakland Auditorium and relayed considerable traffic to other men in the section under the call of W6ADD. W6IP, CRM, was the next highest man in spite of the fact that a great deal of his time is taken up with his duties as a CPO in the Naval Reserve. W6EIB, another Naval Reserve man at Vallejo, has been keeping a sked with old K1PW. W6ALX is keeping things humming in his new shack with skeds, traffic and code instruction. W6BCN ran up a big P. I. total through his sked with K7LG. W6CGM worked in on the news of the finding of the Southern Cross when Smithy and his mates were lost in the Australian bush. W6DWI is burning up 14 mc. with DX traffic and has been keeping a sked with W6AAU on the Chilkoot at Kodiak Island, who is using a small portable under the call of W6ZZE. W6RJ is getting out better with fundamental antenna and counterpoise. W6BI has been doing Alaskan traffic exclusively through skeds with K7AER and his old standby, K7AFR. W6BIW makes his bow as a traffic man this month with a sizeable total. W6SR has a 50-watter in a high C Hartley. W6CGM has a new pup for shack mascot. W6CTX slapped out some traffic. W6FDK is rebuilding his set. W6EBA has been running up the light bill calling K1HR and AC8AG. W6ZA thinks he will get a crystal soon. W6BPC is still holding that same old sked with WSBS and says WFA of Byrd Expedition rolling in in fine shape. W6BMS reports that the Chevvie is sold and that the garage is now devoted entirely to amateur radio. W6OT has been gathering traffic. W6ASJ has been up in Isleton putting in a big electrical installation. W6EJA has been on the air three weeks with a UX-210 and managed to QSO Alaska. W6EDR is building a frequency meter. W6HZU bought a crystal. W6ALV is getting ready for his annual trip to Alaska. W6IM wants a transmitter. W6EY is active. W6CMG is busy with school work. W6RUX is selling out, but he hopes not for good. W6CZR worked W6AM at Tacoma with Don using the small portable and W6CZR oping at W6CKG in his back yard. W6ARU will be on soon with a 210. W6IT is busy with plans for the tri-section hamfest as proxy of the ORC. W6GQ plans to work his son, W6CFD, at Roy scout encampment. W6AUT, W6CZN, W6BYS and W6CUO all reported.

Traffic: W6ADD 500, W6IP 301, W6EIB 179, W6ALX 177, W6BCN 120, W6CGM 108, W6DWI 103, W6RJ 66,

W6BI 55, W6ELJ 51, W6BIW 47, W6SR 29, W6CTX 25, W6EDK 22, W6EBA 22, W6ZA 21, W6BMS 16, W6BPC 16, W6OT 14, W6EJA 10, W6ASJ 6, W6BZU 4, W6EDR 4, W6ALV 3.

SACRAMENTO VALLEY—SCM, C. F. Mason, W6CBS — Traffic: W6EEO 524, W6CGJ 27, W6BDX 53, W6ETA 204, W6DYF 11, W6CLH 308, W6AFU 58, W6BYB 140, W6DON 202, W6ELC 32.

SAN DIEGO — Acting SCM, H. A. Ambler, W6EOP — Well, gang, we not only lost our SCM, W6BQ, but also our brass pounder, W6AJM. We all are surely sorry to see you both leave this section and wish you both success in your new positions. W6DNS leads in traffic this month and is trying to arrange skeds with the Philippines and Hawaii. W6BQ says that he will be off the air for an indefinite period. W6RAS is still recalibrating frequency meters. W6BVX handled a few this month. W6EOP had the pleasure of working his old friend, W9HN the other morning. It was just 19 years ago that they held their first QSO at the great distance of one mile. W6ERT handled a few this month. W6ACJ is building a new xmitter. W6EC is being heard regularly in New Zealand on 28 mc. W6RAM is also trying 28 mc. W6CNK is very QRL school. W6BGL is QRL with ranch and new house. W6BFE will be on soon. W6EPZ certainly is stepping out, has sked with K1CM and reports very good DX. W6EPF expects to get an ORS ticket soon. W6CTP will be on 14 mc. soon. W6AKZ is QRL BCL business. W6ANC and W6EPF worked Byrd.

Traffic: W6DNS 213, W6BQ 104, W6ACJ 101, W6EPZ 78, W6EC 61, W6BGL 42, W6EOP 36, W6HAM 23, W6ANC 19, W6EPF 18, W6RZD 17, W6CTP 15, W6BVX 13, W6BXI 11, W6ERT 9, W6CNK 2.

NEW ENGLAND DIVISION

CONNECTICUT — SCM, C. A. Weidenhammer, W1ZL — W1VE is the proud possessor of a new commercial ticket. W1SA handled a few at Yale. W1RP keeps four schedules with Central American stations. W1BHM and W1BJK are still on the job. W1MK states that a new receiver is in operation. W1BI-W1BQH has moved to Boston. W1OS has her outfit in operation again. A rectifier tube "went west" at W1ATG. W1AVT rejuvenated a 203A. W1BNS has a new Hudson sport roadster. W1BGC is active on 7250 kc. W1TD still has the old power leak. W1BDI has been busy with the convention, board meeting, and other things. W1AFB and W1AMG handled a few. W1AOI reports that W1ANA and W1HN are expecting to be on the air shortly. W1CKP has schedules with W1HE and NX-1XL. W1CTI was ill but now is more lively than ever. W1AMC, W1ADW and W1BOD did some nice DX work. W1PE served as pinch-bitter for W1VB while the latter was moving. W1ZL handled messages for the Nautack basketball team which went to Chicago. W1AJI scared up the traffic. W1AFP is with the Ward Line. W1AMQ reports the formation of an amateur radio club in Milford.

Traffic: W1MK 1038, W1AMG 111, W1VE 3, W1VB 42, W1BJK 24, W1BHM 53, W1AVT 3, W1BNS 21, W1BGC 6, W1TD 43, W1BDI 146, W1AFB 53, W1PE 159, W1AMC 12, W1AOI 46, W1ADW 16, W1CTI 46, W1CKP 49, W1BOD 14, W1RP 80, W1SA 30, W1ZL 12.

RHODE ISLAND — SCM, C. N. Kraus, W1BCR — W1BLS lost his only fiver and expects to get a 210 soon. W1BLV reports his power supply dead. W1MO has his new station nearly completed and will be on 14 mc. soon. W1AWE has been QSO ON stations on 20. W1BCR was QSO KFR5. W1BCR would like to trade stamps by radio. KDV5 sent him a bunch for a starter. W1CPH is on 56 mc. with a 210 and a pair of 866s. W1AVH is also on 56 mc. with 210 and 281s. W1AGI reports working on 7000 kc. band. He is QRV to QSP.

The Radio Club of Rhode Island received notice of its affiliation with the A.R.R.L. Good cooperation is expected by the SCM from the new hams in the organization. Chester Page represented the club in the stunt contest at the convention while Miss Betty Bradshaw, treasurer, put on an entertainment "The Radio Widow" (a monologue). Hi. Good speakers and entertainment are promised. Outside hams are invited to attend. Amateurs interested in 56 mc. tests are asked to get in touch with C. N. Kraus, 92 Keene St., Providence, R. I., for skeds.

Traffic: W1BCR 67, W1BLS 38, W1AWE 3, W1BLV 3, MAINE — SCM, Fred Best, W1BIG — Three members of the Brass Pounders' League this time, gang! Schedules and a fine corps of operators in the Pine Tree State explains the excellent results obtained along traffic lines. FB, fellows. W1AQD took all honors for high totals this month. W1AUS ran number two and now leaves for Kelly Field, Texas to learn the art of flying. W1AUR is number three with a good total. W1ATO turned in his usual fine total. W1ANH and W1AHY have been originating some excellent messages this month. W1CQS sends in a mighty nice string of messages. Mrs. W1AJC as usual triumphed the OM. W1CDX and W1COV handled a good number. W1TB, W1AJG and W1AQL handled a few. W1ASJ is doing some nice work. W1BFZ is trying hard to land that WAC certificate. W1KQ and W1BCD barely got their reports in on time.

Traffic: W1AQD 299, W1AUS 221, W1AUR 213, W1BIG 186, W1ATO 128, W1AHY 84, W1CQS 62, W1AJC 27, W1CDX 26, W1COV 18, W1AJC 9, W1AQL 8, W1TB 8, W1ANH 146, W1BFZ 5, W1KQ 26, W1BCD 45.

VERMONT — SCM, C. A. Paullette, W1IT — W1CGX leads the Section with a fine total. He plans to retain his schedules for rag-chewing. W1BDX has rebuilt and turns in a very good report this month. Say, boys, when you have your summer lay-off, will you kindly let me know on the last report card that you send in that you will be inactive and for approximately how long? W1BCK is having a good time in training school in Ga. W1IT has changed to DC plate supply now. W1AOC is using stal control now. W1BJP is QRL orchestra. W1BDX has a complete new station. W1YD, W1BEB, W1AJG and W1FN report.

Traffic: W1CGX 229, W1AOC 102, W1IT 54, W1BDX 42, W1YD 4, W1BEB 3, W1BJP 7.

NEW HAMPSHIRE — SCM, V. W. Hodge, W1ATJ — W1IP has sworn off YLs and maybe that accounts for his fine total. W1UN sends in a fine report, even though he was away for a while. W1AUE is still hunting for a good stal. W1BFT is building a new transmitter. W1AFD has a 1929 transmitter and note. W1AEF had to cancel his skeds on account of work but is on after 7:30 p.m. W1AUY has spring fever. W1COW is on his way home (Portland, Ore.), where he will sign W1ANZ. W1IX is still the envy of us with his nice note. W1AVJ has been busy printing QSL cards. W1MS and W1AEF have been pioneering on 28 mc. W1BST is on occasionally. W1TA is drilling with the Naval Reserve. W1MB is having a fine cruise on the U.S.S. *Bushnell*. Robert Ballard is also drilling with the Reserve, operating at W1BFT.

Traffic: W1ATJ 137, W1IP 107, W1UN 35, W1AUE 31, W1AEF 9, W1IX 6, W1AUE 2.

EASTERN MASSACHUSETTS — SCM, E. L. Battery, W1UE — W1CQ sends in another of his crack totals — 376. W1ACH, W1ACA, W1KY and W1KH make the BPL on deliveries. W1RF is busy with school work. He has been one of our best ORS for 3½ years and an "honorary discharge" is gladly granted. We have three new stations reporting this month — W1BAQ, W1RL and W1EK, exSCAE of Erie, Pa. W1EK is using a 210 with 500 volts DC. W1RL keeps a schedule with W1BAE. W1KY expects terrible QRM soon, as a frigidaire is being installed in her home. Hi. She has joined the Naval Net so finds it necessary to cancel one of her W1MK schedules. W1BZQ has to have his schedules between midnight and 2:30 a.m. and doesn't find many very anxious to keep them at that time. W1ARS is keeping four schedules. W1ALP and W1BVL are troubled with New Ford QRM. He has new receiver using AC tubes which is the berries. W1KH made the BPL on deliveries, all of which came from the Grenfell Mission. W1AKS is being put on the inactive list until next fall. W1APK is demonstrating television at the Home Progress Exposition at Hartford. Winter traffic schedules have terminated at W1LM for the summer season. W1WU will soon be ORS. W1WV had a fine trip to West Indies, March 26th to April 13th. W1UE is getting a number of inquiries from new hams just starting up, which looks good since new fellows always have plenty of pep. W1CQ had a visit from W1ARG and paid a visit to W1XV. W1ACA says Navy drills helped his traffic total. W1AAW has schedules with W8ARX, W1KQ, W1ARS and W1UE. W1ASI has made connection in the engineering department of Rathcon Company. W1ACH expects to have

a couple of 866 tubes soon. W1ALY is moving to Brant Rock for the summer, where he will be on with a 250 watter; call will be W1RV. W1AZE worked two ZL stations on March 23. W1RY asks to be put on inactive list. W1BST says ex8T9 is now located in Newburyport and is signing W1AGV.

Traffic: W1CQ 376, W1ACH 222, W1ACA 150, W1KY 108, W1KH 83, W1LM 135, W1AKS 84, W1WU 82, W1AKS 47, W1BAQ 41, W1BZQ 31, W1APK 29, W1AAW 27, W1ASI 21, W1WV 13, W1UE 11, W1EK 9, W1RL 4, W1BVT 3.

WESTERN MASSACHUSETTS — SCM, J. A. Tessmer, W1UM — W1BGM is busy with Navy net. W1BNL's new QRA is 40 Abbott St. W1AQF and W1OF went on a fishing trip to the Berkshire Hills and carried on a schedule to let the folks at home know how the fish were biting. W1AWW also was out on a fishing trip with W1OF and worked around east fine with portable. W1AAW is on every Sunday morning from 9:30 to 10:30 a.m., also most weekdays from 7:30 to 8:00 a.m. W1ADO and W1AZD are quite busy. W1BKM has a tube rectifier. W1AQM is building a receiver. W1AKZ has been on 14,000 kc. W1BSJ is rebuilding. W1BVR graduates in June. W1BWW reports that Harry Fiske of Westfield, Mass., whose old spark call was ex1BYU, is now W1DR. W1NS expects to move into his new shack soon. W1CTF, a student of the Eastern Radio Institute, will complete his course next month and will try for a commercial ticket. W1AIZ is sure to be on the air vacations and holidays. W1BKQ is rebuilding. W1BIX wants schedules south and west.

Traffic: W1ADO 13, W1EO 12, W1AZD 87, W1BKM 8, W1AQM 3, W1AKZ 5, W1BGM 32, W1BNL 1, W1AQF 8, W1NP 15, W1NS 9, W1CTF 3, W1ASU 6, W1GR 8, W1UM 2, W1BIX 39.

DELTA DIVISION

ARKANSAS — SCM, Henry K. Velte, W5ABI — W5FP has been having trouble with his rectifier. W5JK, who has been off the air for quite a while, sends in a nice report. W5HN is getting out fine with an 85Z. W5ARA handled some traffic with KDV5. W5HDD is going to school. W5BCZ keeps on the air regularly and handles traffic. He is using an 85Z tube. W5ABI burned out some rectifier tubes. W5ZZA is busy with groceries.

Traffic: W5HCZ 53, W5EP 26, W5JK 26, W5HN 14, W5ABI 8, W5ARA 5.

MISSISSIPPI — SCM, J. W. Gullett, W5AKP — W5FQ is rebuilding. W5ANP has had his ORS cancelled on account of failure to report regularly. W5BBX raised his antenna and increased the range of his so-called 7½ watter considerably. W5AJJ burned out an M-G and W5AWP bought one. W5TX has his MOPA working fine. W5LY is using the 14,000-ke. band for the summer. W5BDE's transmitter has gone Democrat and refuses to work. True & Roy Gullett of Booneville have purchased the 100-watter that strutted its stuff at W5AKP. W5CQ turned in a good report and is one of the best operators in the state. He has schedules with the following stations: W5WF, W5ACH, W5AQY and W4KY. Gang, that is the reason he is high traffic man in Mississippi. W5AKP is constructing a new transmitter, receiver and antenna system. Take a tip from the SCM and watch the Miss. gang take the cake from the rest of the Delta Division in the near future and also keep it.

Traffic: W5CQ 101, W5AJJ 18, W5AKP 78.

LOUISIANA — SCM, M. M. Hill, W5EB — W5WF tops the list for our section by making the BPL agadu. FB, OM. That's the stuff of which real amateurs are made. W5ANA blew his 210. W5BDY is teaching a new fellow the ethics and practice of the ARRL. W5PG has his 310 rattling cans for Hawaii and other DX lately. He is moving to 14,000-ke. band for the summer. W5AFE has been in Chicago. W5NS is a traveling salesman. W5CJ has installed a crystal. W5LY says the OW is on regularly. W5AXS had a blow out. W5BDJ is the proud father of a new YL. W5BBO has improved his note. W5AYZ keeps the tubes ready for traffic. W5EB is ready to help any of the fellows if he can in any way do so.

Traffic: W5WF 217, W5EB 65, W5PG 39, W5BDY 15.

HUDSON DIVISION

NORTHERN NEW JERSEY — SCM, A. G. Wester. W2WR — W4AFG has moved into Ridgewood and is now W2NZ. W2WR has been on 7000 kc. W2AOS is doing fine work for the Army net as NCS. W2BDF is still working hard on WAAM's transmitter. W2CTQ is back on the air with a 1929 installation complete. W2MD and W2CJX are doing fine work. W2BY is still having antenna troubles. W2IS has YL QRM. W2CO got a card from Germany. W2AOP was servicing BCL sets.

Traffic: W2AOS 34, W2BDF 6, W2MD 102, W2CJX 32, W2BY 2, W2IS 8, W2CO 18, W2AOP 6.

NEW YORK CITY AND LONG ISLAND — V. T. Kenney, Acting SCM — Manhattan: W2SC makes the BPL two ways. W2BGO makes the BPL. W2OV will be a six during his vacation. W2AFO has rebuilt. W2BCB and W2BDJ are heard regularly on Army schedule. Bronx: W2CYX handles a goodly number. W2BPQ is very busy recruiting new Army stations. W2BFX will be W2FF in the future. W2ABS, W2SF and W2AET are soon to be ORS. W2AET is on the air. Brooklyn: W2BFQ keeps 27 schedules weekly and rates second highest in the section. W2PF keeps the Army stations lined up. W2BO routes traffic to KFWU, Yacht Fortune, daily. W2BIV is rebuilding. W2CRB and W2AJL are on the air again. Long Island: W2AVP, RM for Long Island, maintains his schedules with all U. S. districts. W2AEU, W2TV and W2AZU are handling traffic regularly. W2AOJ is on 3750 kc. with crystal and is slated for ORS appointment. Staten Island: A delegation will be sent to Staten Island soon. We never hear any signals from there and do not even get mail, so there is a doubt as to its existence.

Traffic: Manhattan: W2SC 401, W2BGO 226, W2OV 29, W2AFO 22, W2BCB 16, W2BDJ 11, W2BO 11, Bronx: W2CYX 42, W2BPQ 41, W2FF-2BBX 29, W2ABS 27, W2SF 33, W2AFT 7, W2AET 3, Brooklyn: W2BFQ 251, W2PF 43, W2BO 29, W2BIV 20, W2CRB 14, W2AJL 14, Long Island: W2AVP 85, W2AOJ 22, W2AEU 19, W2TV 9, W2AZU 6.

EASTERN NEW YORK — SCM, F. M. Holbrook, W2CNS — W2QU made the BPL by keeping daily schedule at 7:30 p.m. with un1NIC, using 14 mc. and 7 mc. W2LU handled good traffic. W2ANV still handles weather reports for Montreal Air Mail and would like help from W2AUQ. W2ACD worked PKR, ship off Porto Rico. W2AXX goes on the inactive list with well-earned rest for few months. W2AYK was slowed up by bad QRN. W2BFF had W1RP an W2BOX as visitors. W2AGQ is back on the air. W2BKN is on deck. W2JE worked NR2WD for traffic. W2AUQ has a new loud-speaker YL — arrived April 1st. W2AGR's aerial blew down. W2ABY is junior op on WADT, S. S. Guatemala en route to Havana and San Francisco. W2MZ and W2BY, please send QRA to James Ballinger, Curdie St., Camperdown, Victoria, Australia.

Traffic: W2QU 105, W2LU 56, W2ANV 47, W2ACD 42, W2AXX 22, W2AYK 16, W2BFF 10, W2AGQ 6, W2BKN 2, W2JE 6.

MIDWEST DIVISION

IOWA — SCM, H. W. Kerr, W9DZW — W9BCA tops the list and gets back into the BPL. Our RM, W9EJQ, is runner-up with only a half-month on the air. Griffith, like others, canceled skeds on account of work, but is planning for another season. Several first reporters: Welcome to W9GCP, W9DVS, W9FDL and W9GDR. W9DRA has gone to Tennessee as operator for WSIX. W9BJJ reports five action stations at Council Bluffs — let's have more reports. W9EHR's fifty went to a needed rest. A 171A is on duty now. W9EHN still sends the OB. W9BAT reports W9EFS rejuvenating for the breeze. A new sig — W9CGN at Badger, Iowa. W9EJQ plans entire new antenna system for fall use. W9DXP has a fine sig on 7090 kc. W9FIF visited W9DZW. W9CZC and W9DZW were guests of Tri-State Amateur Radio Club at Sioux City the 4th. Fine bunch of fellows, doing more experimenting than traffic this season. W9FYC using pair of 2S1's in new power supply. W9EITW runs a chix hatchery, besides. W9DZW is on 7000 kc. for daily QSO at 12:45 noon. Keep the reports coming, gang!

Traffic: W9BCA 215, W9EJQ 188, W9DZW 112, W9FZO 69, W9EHR 49, W9GCP 39, W9FFD 32, W9FLK 29, W9ELW 27, W9EHN 21, W9BAT 18, W9DVS 16, W9DXP 15, W9RIJ 12, W9FDL 10, W9FCY 9, W9GDR 4, W9DPL 1.

KANSAS — SCM, J. H. Amis, W9CET — Kansas has broken all records in the history of the Section with a total for the month of 1860 messages. Very FB, gang, and keep the good work up. Again W9FLG wins the honors for traffic with a total that has never before been equaled in this section. He is now keeping 13 skeds which he claims is luck. Extra! the fone men take traffic honors, with W9ESL in second place with over 400 messages and W9GHI in third with over 200. W9CCS is 2nd up at W9GHL. W9FUG is rebuilding. W9CKV plans a new set. W9ERO is using a 112A. W9DPG is on 1750 and 3500 kc. with fone and keeps skeds on both coasts. W9HL has a receiver at the power plant. W9CFN has a new 852. W9BHR and W9SS are on 7000 kc. W9LN has been sick. W9CET is installing 866's to run a new 860. W9FTY blew his plate transformer. W9FYP is rebuilding. W9BUY claims he is on deck. W9DIH is installing vitaphone in his movie house. W9JU has moved to New Mexico. W9FLG, W9ESL and W9GHI all make the BPL. Fine work, this month, fellows, let's have more of such reports. Remember RM nite — 8 p.m. on 3500 kc.

Traffic: W9FUG 147, W9GHI 206, W9CKV 8, W9ERO 18, W9CET 142, W9DPG 82, W9BHR 47, W9HL 6, W9FLG 538, W9ESL 408, W9CFN 24, W9SS 27, W9FTY 72, W9LN 155.

NEBRASKA — SCM, C. B. Diehl, W9BYG — W9FAM leads the section this month. W9CBK comes second with another good total. W9DTH works DX on 14 mc. W9DNC has rebuilt. W9DI builds a chemical rectifier. W9BOQ works on 8500 kc. now. W9CHB has several schedules. W9BBS and W9ANZ are with us. W9CDB lost his tower. W9BQR is using low power. W9FJD and W9DVR are going strong. W9FJL sends in his first report. W9EEW has been sick.

Traffic: W9QY 14, W9DTH 2, W9DVR 4, W9FAM 42, W9DNC 16, W9DI 1, W9BOQ 6, W9CHB 19, W9BBS 2, W9FJL 10, W9CBK 40, W9FJD 8.

MISSOURI — SCM, L. B. Laizure, W9RR — W9DOE led St. Louis traffic with one sked only. W9DOE, W9DXY, W9PW and W9EAZ are candidates for commissions in the USNR. W9DZN resumed sked with W9DQN. W9GEK handles plenty of traffic. W9BEU worked WFA, taking msg for local delivery. W9DUD has school QRM. W9GHG is a new ORS. W9ECS led the section for traffic, keeping three skeds. W9ASV is building a new set. W9DZN and W9EUB are schedule-keepers. W9GBT and W9CJB did some good work. New station in Fayette, W9CNV. W9FYM has fallen heir to the most of the equipment of W9WV, who died this month. W9FVM runs code class Sunday p.m. at 4:30 CNT. He was appointed district A-A station. W9AJL is new station in Mansfield. W9FBF did some visiting this month. Ex-9BCJ of Webster Groves is now W9EH in Phoenix, Ariz. W9ERM has moved to Fulton. W9AJW is on at W9BEK while away at school and wants to QSO the home gang. W9EPX has a new xtal. W9TJ moved back to the country for the summer. W9RR still on and shelf and camping at W9DQN. W9ALC is a new ORS prospect. W9ZD is experimenting as usual and QSY'd to a new job. W9BSB is rebuilding. W9DOJ was moved out of town due to change in his job with the telephone company. W9GCL, W9DKG, W9DEN, W9DMT, and W9GFV report variously with a little traffic. DX, and the usual operating troubles.

Traffic: W9DOE 51, W9DZN 43, W9GEK 31, W9BEU 12, W9DUD 3, W9GHG 1, W9ECS 166, W9ASV 21, W9EUB 18, W9GT 21, W9CJB 11, W9DKG 5, W9DHN 7, W9DMT 5, W9FVM 4, W9FYM 2, W9GFV 2, W9FBF 4, W9DQN 16, W9ALC 9.

DAKOTA DIVISION

NORTH DAKOTA — SCM, Bert S. Warner, W9DYV — W9BVF takes the lead this month with a very nice traffic total. W9IK, W9DYV, W9DYA, W9FCA and W9CDO reported. It is with deep regret that I have to report the passing of one of the ORS members of this section, Mr. T. C. Lockrem, W9BJV, who passed away

very suddenly a short time ago, and he will be very much missed in this section, as he was a friend to all the hams who knew him and always ready to assist any new ham in getting started and seeing that he made progress along the amateur lines.

Traffic: W9BVF 161, W9IK 2, W9DYV 2, W9DYA 2, W9FCA 1, W9CDO 1.

NORTHERN MINNESOTA — SCM, C. L. Jabs, W9BVH — W9EGU still keeps a nice bunch of schedules and also has a portable station on the air, using an input from one to two hundred watts, call W9GZ. W9AOK is putting up a new Zeppelin antenna. W9BBT works on 3500 and 7000 kc. W9CTW is moving. W9ADS is on with a 210. W9DPB forgot to renew his license. W9EHO has a new xtal transmitter. W9CKI and W9BVH are on 14 and 7 mc. W9CF is studying for a commercial license. W9BCT is on for A-A skeds. W9CIY called on the SCM during the month. W9EGF is on at W9LD, Cahmet, Mich. The SCM is going on a trip to Washington, Oregon and California this summer and will carry a portable and would like a few schedules with stations in this section.

Traffic: W9EGU 177, W9AOK 89, W9BBT 52, W9CTW 35, W9ADS 28, W9EHO 19, W9DPB 18, W9CKI 18, W9BVH 11, W9CF 5, W9BCT 2, W9CIY 2.

SOUTH DAKOTA — SCM, Dwight M. Pasek, W9DGR — W9DGR has the largest total of all stations in the Section this month. W9EUB is on regularly with a real "29" signal. W9BBF has a UX250 outfit. W9FNN has some new mercury-vapor tubes. W9AZR-W9ESD is in line for an ORS appointment. W9DB is on 3.5 mc. on Sundays and finds the DX very good on 14 mc. W9DLY is working W9BT, WFA, CE, K1, etc. and handled press with W9CYX and W9DLY during a snowbound period. W9DWN had a sked with Los Angeles, W9AVJ, and kept a man in Pierre in daily communication with his daughter who was very ill but who has since recovered. W9DNS reports W9AJP and W9DRB active. W9DIY is on 3.5 mc. now and will be on 7 mc. by the first of May. W9CKF reports W9CHR as a new ham. A nice bunch of reports this month, gang. let's keep it up.

Traffic: W9DGR 49, W9AZR 28, W9EUB 26, W9DWN 25, W9DNS 23, W9DLY 18, W9DIY 18, W9ESD 15, W9DB 11.

SOUTHERN MINNESOTA — SCM, J. C. Pehoushek, W9EFK — The Twin City Radio Club suggests summer hamfests — what do you say, gang? Eleven ORS cancellations were made this month — all for non-reporting. I heard indirectly that W9COS employs a secretary and a sonnambulist as station necessities, handled 325 and delivered 160. Boy, how do you need them both. W9DOP got QSA8 from NZ and wants to know how loud that is. W9AIR and W9BKX want all Army-Amateurs to be on 3500 every Monday night. W9AMK has a 210 on 3500. W9EFK was on 7 days this month. W9ELA still works DX with that 210. W9BTW plans crystal control. W9EOH handled a few between Minneapolis-to-home trips. W9AIR says W9BKX has the prettiest job he ever saw and he has seen lots of them. W9DBC has YL QRM. W9CFD will be in Wisconsin all summer. W9BHZ has a new antenna. W9EYL likes 3500 kc. fone. W9ERT handled a few. W9DMA reported. W9CRW (See's All — Knows All), Tommy Edmunds, of Convention Fame, got himself tangled with the tornado that demolished WRHM and suffered the loss of his trousers in the gale. Tom was cut slightly and bruised more but is FB now.

Traffic: W9COS 325, W9DOP 35, W9AIR 31, W9AMK 16, W9EFK 18, W9ELA 11, W9BTW 11, W9EOH 10, W9BKX 8, W9DBC 7, W9CFD 6, W9BHZ 4, W9ERT 3, W9EYL 6.

CENTRAL DIVISION

OHIO — SCM, H. C. Storek, W8BYN — W8CNO leads Ohio again this month 212 messages, despite trouble with rectobulbs. Certainly FB! EXTRA! W8GZ is with us again and makes the BPL with 206 msgs. FB, and keep it up, OM. W8CMB upheld traditions in gallant style. W8CKI expects to go to 7000 kc. with schedules soon. W8BBR also turns in a nice one. W8BKM got 109 lined up. W8DDF put a few through. W8CWC is a golf nut. W8DJV is on with an 852. W8CXW likes 3500.

WSADS has school QRM. W8CIY reports QRL YL's and business. W8BAU has been active in A-A work. W8DDK turns in a nice total. We lose W8KN again for the summer. W8CSS is on 3500. W8DDQ still wants high school schedules. Get together, W8ARM and W8DDQ. Imagine three brothers fighting for one key—that's W8CFT. W8ARP reports. W8ARP and W8DVL handled some. W8OQ, W8CNU, W8ALW, W8BAH, W8AYO and W8ARW handled a few each. W8QU, W9DII, W8JA and W8DAE knocked a couple down. W8CCS, W8APB and W8EJ caught one or two. W8DHS, W8DSY, W8CXD, W8CFL, W8BBH, W8RN, W8BKQ, W8ALC, W8LI and W8PL said hello.

Traffic: W8CMB 220, W8CNO 212, W8GZ 206, W8BYN 198, W8CRI 157, W8BBR 147, W8BKM 109, W8DDF 80, W8CWC 69, W8DJV 47, W8CXW 47, W8ADS 36, W8CIY 34, W8BAU 34, W8DDK 33, W8RN 26, W8CSS 24, W8DDQ 19, W8CFT 18, W8ARP 17, W8DVL 14, W8OQ 9, W8CNU 8, W8BAH 8, W8AYO 8, W8ARW 7, W8QU 7, W8DII 6, W8JA 6, W8DAE 5, W8CCS 3, W8APB 3, W8EJ 2.

KENTUCKY—SCM, J. B. Wathen, III, W9BAZ—W9FS is our star traffic handler this time. He is now tied with W9OX in the "Fight for the Pint." One month each. Who will make it the "Eternal Triangle"? W9BXC says he is climbing the ladder to the BPL. W9JL has the usual fine total. W9FKM promises a 250 with xtal. W9BWJ let his license expire. W9FBV is working hard to get on the air again. W9GGB and W9GJG have applied for ORS tags. W9GGB wants to QSY Ky. stations on 23 mc. W9ARU is painting. W9FZV says everyone is QSA-5 on his new receiver. FB, OM. W9MN now has a "pink ticket." W9AZY gives promise of big doings. W9OX has had considerable trouble with his new antenna. W9CEE is QRW with work and school. W9EYW has had troubles galore. W9ENR is looking for DX on 14 mc. W9BAZ is the proud owner of a niece of Henry Ford. Will use her to visit the gang week-ends. W9GAL copyrights—"Traffic not as good on 40 as on 80." W9BAN was QSO Oslo, Norway. W9FQN has been appointed ORS. Reports showed a decided change for the better. Keep up the fine work and we will soon lead the Division. When we do, it's a dinner for all at my expense. That's a promise. Sic 'em, gang.

Traffic: W9FS 226, W9BXC 114, W9JL 85, W9GGB 45, W9BAN 26, W9ARU 22, W9FZV 19, W9BAZ 17, W9GAL 17, W9MN 13, W9AZY 11, W9OX 11, W9CEE 5, W9EYW 5, W9GJG 5, W9ENR 3.

MICHIGAN—SCM, Dallas Wise, W8CEP—W9BTQ now has the 852 perking. W8LJ is a newcomer. W8DED has dropped most of his schedules and will rest up some this summer in order to be ready for the fall rush. W8BV has sold his 210 outfit. W8ZF has a new receiver. W8JD handled a nice bunch of traffic and did some very fine DX with a 210. W8KD is the only ham in town and suppose he gets blamed for all the QRN, etc. W8AAH is having trouble getting his station license renewed. W8BGY is doing a little DX now and then. W8ACB has a new transmitter and receiver now. W9CE manages to radio a little now and then. W8AUT has been going pretty well. W8AUB says they missed out on doing some emergency work during the recent storm due to no station in Ludington. W8AJL now has his commercial license. W8DFS blew his transmitter tube but came back with a couple of 201A's. W8CAT is still trying to get a tone working on 3500 kc. band. W8DSF will be on 14,000 kc. for the summer. W9AXE says the DX is FB. W8DYH lost his antenna in the recent breeze. W8CKZ has been silent due to business. W8CU is rewiring the house. Walt Colpus of Pontiac, reports the sector quiet around there. W8CWK is in the BCL business.

Traffic: W9BTQ 16, W8DED 187, W8RV 3, W8ZF 1, W8JD 52, W8KD 30, W8AAH 7, W8BGY 38, W9CE 27, W8AUT 16, W8AUB 14, W8AJL 15, W8DFS 36, W8CAT 23, W8DSF 31, W9AXE 9, W8DYH 183, W8ASO 5, W8CKZ 9, W8BRS 19, W8CEP 15.

ILLINOIS—SCM, F. J. Hinds, W9APY—W9AFB has a good DX on 14 mc. W9DGK has a new 1929 TPTG. Look out for someone illegally using W9IZ's call with AC on 14 mc. in the morning. W9AVL is busy getting W9AKL on the air at Millikin University. W9BPX works good fone with a YL in Missouri. W9AP is down on off-wave stations.

W9BVP and W9FCP are moving. W9CIA works Australia and Asia on 14 mc. W9NV lost a mast and a 75 watt. W9CUH is going to 14 mc. for the summer. W9BNI says he will never move again. Hi. W9CKZ is one of our new ORS. W9KA is now USNR. W9KB has a new Hi C TPTG. W9CZL has a brand new 250 watt. The new Chicago Radiophone Club is coming along nicely. W9DOX is busy with W9CNH. W9FDJ worked Egypt, Chile, and England. W9CRR is one of our new traffic men. W9CRR is installing a 14 mc. outfit. W9EYA has rebuilt. W9FMR has a new Zepp. W9CNH is doing fine traffic work in the 20th Century Route. W9GJ recommends DC for plate supply. The Austin Radio Club has an Aero TPTG going with call of W9BZD. W9DII and W9BOL sport new apparatus. W9ERU has been busy chasing Broadcast harmonics. W9BXB and W9FFQ are trying out 14 mc. W9CNY likes his new voltage fed Hertz.

Traffic: W9ERU 243, W9DXZ 226, W9EJO 122, W9BZO 85, W9FI 82, W9APY 54, W9CNH 43, W9GJ 42, W9DFY 38, W9CIA 37, W9FDJ 34, W9AP 20, W9CZL 20, W9AFB 15, W9FO 14, W9CUH 13, W9FCW 12, W9CKX 11, W9CRR 10, W9IZ 10, W9BFX 9, W9AVL 8, W9KA 8, W9KB 7, W9FZE 6, W9CNY 5, W9DGK 5, W9FCR 5, W9FBE 4, W9BSH 3, W9ACU 2.

WISCONSIN—SCM, C. N. Crapo, W9VD—W9DLD is cancelling all schedules until fall but will still be on the air at irregular periods and glad to QSP always. W9BPW is using push-pull Hartley and will be rebuilding during the summer period. W9BWZ is anxious for schedules in Madison and also one in Iowa. W9DTK reports that the V3 men are now handling all Fleet Reserve Despatches and communications from week end cruises. W9DLQ will be off the air for a time rebuilding. W9BGT (ex 9CWZ) is on the air again and wants to hear from the gang. W9FBJ (ex W8SO of Hudson) now operates from Madison using a DeForest H tube in Hartley circuit. W9CVI is doing a lot of experimental work. W9EUI sent in four reports from other stations. W9DCE will have crystal going soon again. W9EMD is all set for traffic. W9DJK says the LaCrosse Club has 25 members and going strong. W9LV still strong on deliveries. W9FHU has spring fever. W9FAW is on duty from 6 to 7 a.m. W9SO is building a 4 tube screen grid receiver and experimenting with television. W9EHD sent totals via amateur radio. W9BQJ handicapped by heavy QRN and night work. W9AZN still reports regularly. W9BLB has moved to the basement and now gets on the air a little more regularly. W9DEK, poor cus, has spring fever—new Chevy coupe and a new girl—and the transmitter lay's idle. W9VD is going strong again.

Traffic: W9DLD 348, W9RPW 92, W9BWZ 75, W9DTK 49, W9DLQ 33, W9BGT 33, W9FBJ 31, W9CVI 29, W9EYH 26, W9DCE 26, W9EMD 16, W9DJK 12, W9LV 14, W9FHU 14, W9FAW 11, W9SO 7, W9EHD 7, W9BQJ 7, W9AZN 5, W9BIB 4, W9DEK 1, W9VD 9.

INDIANA—SCM, D. J. Angus, W9CVQ—W9EF was heard on schedule on 23 mc. in Australia, Brazil, England and France. FB, W9EKW wants schedules. W9DBJ has his xtal parking on 7000. 4 kc. W9AHB is putting in 2 852's. W9BKJ is back to 3500 as he couldn't stand the racket on 7000. Hi. W9BZZ is back on the air after breaking his 852. W9AJA, Neil Werner, is back in the ham game after 8 yrs. commercial oping. Location now Hammond, Ind. Welcome. W9ASX is going to radio school at Valparaiso. W9EKW is busy with Army-Amateur work and requests any stations interested in that locality (Richmond) to see him. W9FQ is the new RM for the NW corner of the state. All stations in that vicinity who are not ORS, please get in touch with W9FQ with your reports and requests for information. The license of the telegraph school at Valparaiso, W9RW, has been temporarily suspended. W9EPB is still the only one reporting from Elkhart. W9AFA is going to take a trip with MacMillan in June to Labrador and Baffin Land. W9EVA is going to op on the Lakes this summer. W9FZQ finally connected with his first six.

The Indianapolis Radio Club are going to have a hamfest May 18th and 19th to which all hams are invited. Place, clubrooms at 460 Century Bldg., Indianapolis. Bring your lunch, as there will be fees to cover banquet or anything else. R. B. Annis, Pres.

Traffic: W9EKW 113, W9ASX 59, W9CMQ 60, W9EF 47, W9AJA 33, W9BZZ 1, W9GCO 5, W9PF 3, W9BKJ 8, W9FCG 10, W9AAB 3, W9DSC 43, W9GBF 21, W9EMR 33, W9DHJ 16, W9CNC 14, W9DBJ 17, W9EXW 20, W9CYQ 17.

WEST GULF DIVISION

SOUTHERN TEXAS—SCM, Robert E. Franklin, W5OX—Two stations make the RPL this month—W5AQY and W5ASM. W5ABQ was fortunate in being able to get first hand information from VK2RB concerning the finding of the Southern Cross. W5AQY complains of bad QRN but from the looks of his message total, it hasn't got the better of him. W5ASM sends in his usual nice message total and is keeping several good skeds. W5AAB promises to be one of our leaders in traffic. W5MS reports that Corpus Christi is blessed with two new stations, W5TO, formerly of Aransas Pass, and W5BBY, a new ham. W5LP sends in a good report. W5AHP is punching a mighty hole in the ether. W5LR is on the air again with low power. W5OX has been rebuilding.

Traffic: W5AQY 290, W5ASM 127, W5AAB 112, W5ABQ 38, W5MS 38, W5LP 36, W5OX 19, W5AHP 6.

NORTHERN TEXAS—SCM, J. H. Robinson, W5AKN—W5HY's YL must have quit him. From the looks of his message report. He accuses the SCM of being a BCL ham. A dirty dig, for sure. W5BBF says he has been experimenting with anti-key thump filters. W5ATZ has a funny happening to report: He mailed a message to a girl in Ft. Worth, Texas, from China, relayed through W6CZM. The girl wrote back and said, "Instead of sending fake radiograms, tell 'Bill,' the signer of the message, to get himself to Ft. Worth and QRT the comedy." (We wonder if "Bill" is in China or Denton, Texas.) W5AAE is still getting out wonderfully with his CX210 and the Ford Coil transformer. W5JD is working on a static eliminator. W5BAD has QRM from school activities. W5BAM is on 14 mc. and 7 mc. W5AKN is now W5BG. W5AVD is in the 1780 kc. band. W5DF is busy. W5WW got his report in just in time for the boat.

Traffic: W5HY 45, W5BBF 18, W5ATZ 16, W5AAE 14, W5JD 8, W5BAD 7, W5BAM 7, W5AKN 2, W5WW 34. **OKLAHOMA**—SCM, Wm. J. Gentry, W5GF—I wish to thank all of you for the support you gave me. Gang, the reports sure were poor this time. Let's have more pep now, OMs, and get them in on time. W5BEE is the high man for this month. He and W5ASQ and the rest of the Tulsa gang are getting high power fever. The Alpha Sigma Delta at O. U. are experimenting on xtals. W5AOX and W5KX have stal fone sets now. W5AYF is a new ORS. W5FJ is active. W5GF is building a new outfit. The Army Net is getting started now. Let's report 100% from now on, fellows—will you do it?

Traffic: W5BEE 17, W5ASQ 13, W5GF 6, W5AYF 5.

CANADA

MARITIME DIVISION

NOVA SCOTIA—SCM, A. M. Crowell, VE1DQ—VE1CC and VE1AS are pounding away on 14,000 kc. VE1BV finished his new monitor and says it's FB on the new transmitter. VE1BW is a new ham in Halifax. We regret to report change of QRA for VE1BN and hope to hear him on soon with a "2" call. VE1BR was heard getting a QSA5 from PB7A. VE1DA is on 7500 kc. VE1DM only has Sunday afternoons at the net. DX signals have been remarkably good during the past month, especially the British and African stations. VE1DQ expects to be on the air soon.

ONTARIO DIVISION

ONTARIO—SCM, E. C. Thompson, VE3FC—Southern District: F. W. George, VE3CS, Asst. SCM—VE3AQ tried MOPA, but came back to the old Hartley again. He is handling some traffic which is of importance. VE3DG and VE3BV paid a flying visit to London for the WOARA meeting, and went through fog, storms and floods getting back, but it was sure FB to see them again. VE3CB breaks out by clicking with NJ2PA. VE3HB is loaded up with zepp antenna dope. VE3CS bangs

a signal to SU8RS, Cairo, Egypt. That makes a total of 43 countries now. Central District: VE3BC leads as usual with a fine traffic total. VE3CL works the ninth district. VE3BT is worrying about crystal control. VE9AL keeps two or three schedules on 4000 kc. VE3FC keeps a schedule with W2MY on 3900 kc. VE9BJ uses 4000 kc. VE3HP is on the air again. VE3AL has a portable station at the Home and Garden Exhibition at the Coliseum, Toronto, and has the booth of the Wireless Association of Ontario and the American Radio Relay League. Northern District: VE3AR now boasts a new station under the call of VE3BH. VE3HU gets out very FB with fone on the 1750-ke. band. VE3ET is away on a survey party up north. VE3AR is returning to 4000 kc.

Traffic: VE3BC 38, VE9AL 21, VE3FC 11, VE3AQ 6, VE3HB 6, VE3BO 9, VE3EG 6, VE3CS 4, VE3CB 3, VE3BV 3, VE3CL 3.

VALNATA DIVISION

ALBERTA—SCM, E. J. Taylor, VE4HA—VE4AF is traffic leader this month. VE4GD worked CE3BF on 14,000 kc. The family at VE4EI is getting out FB. Sorry to hear VE4CC indisposed at this time. VE4EG will be on soon. VE4RA is coming out with a fifty. VE4IT is on with various notes. The area at Calgary held nice banquet and meeting, plenty of pep apparent. Glad to see you fellows in the south intend making it a monthly affair. VE4QO is on consistently. VE4EY and VE4EP pretty busy completing portable phone set for Ted at VE4EP. VE4HM is on right along. VE4CU is on every Sunday with official broadcasts. VE4FT has a real DC note. VE4FF comes in right along. VE4JF is doing FB. VE4HA is on 14,000 kc.

Traffic: VE4AF 30, VE4EI 22, VE4GD 8, VE4CC 6, VE4IO 1, VE4EY 10, VE4HM 6, VE4CU 15.

BRITISH COLUMBIA—SCM, E. S. Brooks, VE5BJ—VE5AL has moved to 4868 Blenheim St., Vancouver, and reports having plenty of work to do before fitting up the old heap again. VE5BR put in a small dynamotor and keeps daily skeds on 3500. VE5CO receives lots of crystal reports on his CRAC input. VE9AJ was visited by Ross Hull from Headquarters on his return to Australia via Vancouver and gave the gang some good pointers. Your SCM would sure appreciate some reports. How about it, fellows?

Traffic: VE5BR 33, VE5AL 15.

PRAIRIE DIVISION

MANITOBA—SCM, D. B. Sinclair, VE4FV—VE4IC is still going strong. VE4GQ has a real set on the way. VE4DJ hooked KE6AL on the 14-mc. band. VE4DU heard Japan on 7 mc. VE4DR worked Hawaii. VE4FV thinks he worked Hawaii. VE4DK and VE4FN have steady sharp signals that push out fine. VE4HR is very consistent around the continent. VE4JB gets out very well with his 210. VE4DP took back the 210 at VE4HX, which is now reduced to a 201A. VE4IM will use a low-power set. VE4BD is using a 50 and getting out FB. VE4DI is taking VE4DW's place. VE4DW is visiting in Winnipeg.

Traffic: VE4DK 11, VE4DJ 8, VE4FV 6, VE4FN 5, VE4JB 5, VE4HR 4, VE4GQ 1, VE4DB 2.

SASKATCHEWAN—SCM, W. J. Pickering, VE4FC—Where, oh where, is the Regina gang which is supposed to be so active but never tells anyone about it? How about a little news from you fellows? VE4CM tops the list this month. VE4GO has broken into the message handling game. VE4IH will be on the air Sundays and rainy days this summer. VE4JG spent Easter with him. VE4GR is trying to find a new location free of bathhouse QRM.

Traffic: VE4CM 23, VE4GO 19, VE4IH 12, VE4GR 8.

Late and additional reports:

W4AIQ would like to test with any station including foreigners of any country between the hours of 2 and 4 a.m., CST on Wednesday and Saturday of each week. W9DOE has kept the father of W6EH (Mr. Messman) in contact with his son. W6EH constantly for the past five months. W1YB has schedules with W8CMG and W9FBX. W4CT handled quite a few.

Traffic: W9DOE 51, W1YB 69, W4CT 49.

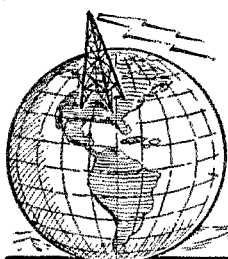

I.A.R.U. NEWS

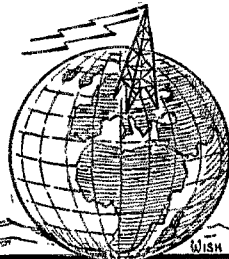

WE had hoped to have the results of the Prague conference to report in this column this month; unfortunately, however, no word has been received of the outcome at the time this department is being written up, and so we must postpone announcements until next month.

As mentioned last month, I.A.R.U. Headquarters was particularly interested in the amateur proposals submitted by the Dutch Government. On the whole, these proposals seemed very satisfactory. Our own State Department asked us to comment on them, for the information of the United States delegation to the conference. In reply to this request, Headquarters submitted detailed comment on every feature of the Dutch proposals.

To supplement this, Secretary Warner had a special conference with Mr. W. D. Terrell, chairman of the United States delegation, just prior to Mr. Terrell's departure for Prague, and further discussed features of the amateur situation. Mr. Terrell was also furnished with the names of various European amateurs and societies. Since he has long been a friend of the amateur in this country in his capacity of Chief of the Radio Division of the Department of Commerce, we know that the European amateur representatives at the Prague gathering found him a sympathetic ally.

In addition to the above steps, Union Headquarters also sent summaries of the comments on the Holland proposals to various officials of certain sections of the Union in Europe whom it was thought would be present at Prague. A copy of the summary was also sent to the officials of the S.K.E.C., the Czechoslovakian amateur society, and one of the proposed new members of the Union.

As this report is being written, the June Calendar of the Union is about to be sent out, this being the first under the new Constitution. Officials of the various member societies will probably have received their copies of this document by the time this issue of *QST* is issued.

In addition to several proposals of new members of the Union, certain other matters of im-

portance are presented for action. We want to again emphasize the necessity for prompt action on the part of all member societies, and request that the votes solicited on certain questions be acted upon and sent back to Union headquarters as rapidly as possible.

As mentioned in the paragraph above, several new societies were proposed for membership in the June calendar. While the next calendar will

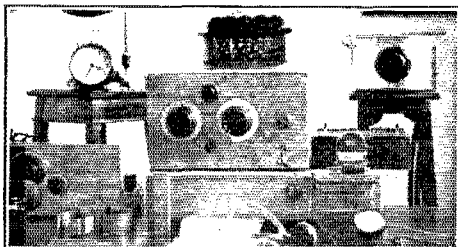

THE STATION SHOWN HERE, AC1TB, IS OWNED AND OPERATED BY MR. F. S. PARSONS, AT HARBIN, NORTH CHINA

Due to import restrictions, much of the station is home-made, Mr. Parsons possessing a lathe and being handy with tools. The station is thoroughly up to date. Note the monitor at the right.

*The transmitter (not shown in the picture) is a loose-coupled Hartley using a single UX210. 500 volts d.c. is obtained by combining 220 volts from the mains and 280 volts from batteries. It is expected that a dynamotor will soon replace this arrangement. The receiver is a tube-base set built from a *QST* article. In spite of extremely heavy local QRM this station has worked all over China and Oceania, and hopes soon to QSO the United States.*

not be sent out until December of this year, we want to urge that any society wishing to apply for membership in the Union take steps promptly. It frequently takes a large amount of correspondence extending over several months to get all the information which Headquarters must have before it can present any society for membership. With this in mind, we urge that societies wishing to be proposed in the December calendar write us promptly.

Membership in the Union is open to any national amateur radio organization.

AUSTRALIA

By W. G. Sonn, Publicity Officer, W.I.A.

The allotment of wavelengths under the terms of the Washington Conference is as follows: 60 to 56 megacycles; 30 to 28 megacycles; 14,400 to 14,000 kc.; 7300 to 7000 kc. and 1900 to 1200 kc. (150 to 250 meters). The last-named was granted for the benefit of the phone workers, of whom there are a considerable number, who carry out work after the usual broadcasting hours, mostly on Sundays. This band is only temporarily granted, however, and will be re-considered at the end of twelve months.

Consternation was very great when it was seen that no provision had been made for us in the 4000- to 3500-kc. band, but after several consultations with the P.M.G.'s Department the whole band was temporarily opened to us until the 1st of July, 1929. It is proposed by the Department to utilize this band for a point-to-point public telephone service between Tasmania and the mainland, and for defence stations, but they are not yet ready to be placed in operation. We are hopeful that with this slight respite we will be able to press our claims so that even a portion of the band may be retained after July, in which all local work can be conducted and thus leave the higher frequencies for international contacts in accordance with the recommendation of the I.A.R.U.

On the higher frequencies, the 7000-kc. band is being utilized more than the 14,000, though a number of stations are gradually finding their way down there and discovering the DX conditions are better (for the present, at any rate), more especially with the G's, who are coming through fairly strongly in the late afternoon, Melbourne time.

Thirty megacycles is very quiet, although most of the gang is plugging away. Contacts, aside from locals, are very far apart. Several experiments are planned, mostly in connection with radiating systems and better results are anticipated with the approach of our Winter season.

In connection with the other alterations to existing regulations to bring them into line with 1929 requirements, the Department has stipulated that all stations must be in possession of a reliable frequency meter, but we are glad that they did not follow the example of the G's in insisting that it should be based on crystal standards! For Aussie requirements, Hull's frequency meter and monitor set should fill the bill nicely.

Sub-standards are to be supplied by the Department to each Division of the Institute, and from these standard frequency transmissions will be undertaken.

Regarding message traffic, we are permitted to exchange personal messages relating to tests, but originating or relaying messages for a third party is still strictly "taboo."

The Defense affiliation which the Wireless Institute of Australia has long been trying to effect is now taking definite shape. The whole scheme has not been adopted, as the Army and Navy have not yet found a means of employing a reserve of amateurs, but the Air Force, visualizing the potential value of an Air Force Communications Reserve, is enthusiastic about it.

The enrollment and organization is now being made and will be very similar to that of A.R.R.L., modified to suit our local conditions. The work of the Reserve will consist of tactical "drills" and exercises, by radio, to train the personnel in Air Force procedure. Weather observations from country districts will also be supplied, a scheme which will be of considerable value in compiling charts on weather conditions over all parts of the Commonwealth, particularly in country districts.

A systematic survey of transmitting and receiving conditions over a great part of the continent in conjunction with Air Force stations is also planned. When the organization is complete, pilots will be supplied with charts on which the location of reserve stations is plotted so that in the event of being forced to land, a station capable of communicating with the aerodrome direct can soon be found, instead of having to endure the delay which ordinary telegraph communication would entail.

BELGIUM

By Paul de Neck, President, Reseau Belge.

On the 7000-kc. band, work has been hampered by heavy QRM, and DX contact is a difficult task. To a certain extent, of course, this is to be expected. ON4EA on this band made the first contact between Belgium and the Isle of Reunion, east of Madagascar.

The 14,000-kc. band is the real long-distance wave, and gives fine results. ON4AR-4RO on low power, ON4EW, ON4DI and others have worked W hams, and in addition, Java, China and South America. ON4EW made the first contact to Ascension Island.

The contact with the training sailing ship, *L'Avenir* (XEB4WK) has been extremely successful. QSO's are obtained daily, with the exception of four days when the ship was in the Antillian seas, just before arriving at Tampa, Florida. We had the pleasure of learning that W hams from the fourth district were visiting the ship in Tampa harbor. It was a great satisfaction to learn that W4TZ, an engineer at WMBL, said the XEB4WK layout was "the prettiest transmitter and receiver he had ever seen!"

We were pleasantly surprised to have a visit here from W2DR, who from the station of our Secretary, ON4OU, had a good fone conversation with the well-known French actor, EFSIL, and had a nice chat with XEB4WK from the station of our Traffic Manager, ON4FT.

In our next report we hope to be able to give some results of the work accomplished by our hams on the 28,000-kc. band.

CZECHOSLOVAKIA

By Jan Bisek, President, S.K.E.C.

In this country, the short-wave transmitting amateurs have formed themselves into a society called the Association of Short-Wave Experimenters of Czechoslovakia — the S.K.E.C. This organization has as its aims the bonding together of amateurs for mutual benefit, the obtaining of license privileges for amateurs, and the maintenance of friendly relations with governmental agencies. Amateur transmitting here is not generally allowed, as yet, but licenses have been granted to some schools and laboratories. The Department of Telegraphs is not actually against amateur work, as evinced by the fact that it has supported the Washington Treaty of 1927. Our only real trouble, in fact, came from the Department of the Interior, which was afraid that amateur stations might be used for propaganda and other undesirable purposes. To over-ride these objections was one of the tasks of the S.K.E.C.

We are glad to state that recent affairs have taken a more favorable turn, with respect to transmitting. The Department of the Interior is gradually coming to the viewpoint that amateurs, in their own interest, would not allow any of their members to misuse amateur privileges. However, for the present, amateur operation here continues to be "under cover" and all QSL cards should be addressed with this in mind.

Negotiations have been carried on over a period of some months with a view to having the S.K.E.C. recognized as the National Section for Czechoslovakia, and it is hoped that we will soon be a member of that great international body.

For the most part, the transmitters here are of low power, although some of them use as much as 200 watts.

In the 14,000-kc. band much more work is being done than a year previously. On 28,000 kc. there is not much activity as yet, although OK-AA2 has heard W2JN with fair signal strength.

FRANCE

By R. Larcher, Treasurer, R.E.F.

Whether due to cold weather during the early part of this year, or to the QRM, we do not know, but at any rate, DX activity was not so great among French hams.

QRM on 7000 kc. has been pretty bad; occasional American signals come through, but trying to work them is extremely difficult, and at times, impossible. During the morning, signals from Australia and New Zealand have been heard with good strength.

Conditions are better on the 14,000-kc. band, due to a great extent to the lesser amount of QRM. F8BTR, F8EO, F8GDB and F8JF are active here. Activity in the R.E.F. has been toward 28,000 kc., however, and in this band regular transmissions are carried on by F8AAP, F8CT and F8JT. F8BU (ex RO10), F8JN, F8KV and F8WC are on occasionally. The head of the R.E.F.'s Oceanic Section (00BAM at Tahiti) is getting ready to operate on this frequency too. F8JN reports hearing W2JN, W1CPB, W2ALW and W8GG on "ten."

Good weather will soon arrive, and with it we hope that the activity of French stations will revive on all wavebands. It is believed that many of them have thoroughly modernized their stations, and that they are now fully equipped to operate in "1929 fashion."

Much interest in the R.E.F. is being aroused over the first French amateur convention, which is to be held June 1 and 2, at Paris. (FB OMs!! A.L.B.) A splendid program has been arranged, with lectures, discussions, visits to nearby commercial stations, and a banquet.

GERMANY

By E. Reiffen, Secretary D.A.S.D.

On the 7000-kc. band, DX conditions became poorer. Good communication with United States stations is now best in the early morning. There is little to be heard on 14,000 kc., although ZS stations came through well around 1700 G.M.T. in the afternoon. We have nothing at all to report on 28,000 kc.

On the 7000-kc. band, a number of low-power transmitters were active, and established many excellent DX contacts. On the 14,000-kc. band, most of the activity occurred on Sunday.

ZL stations are unfortunately heard very seldom since the abandonment of the 10,000-kc. band. A few ZL's have gone over to the 7000-kc. band, so that D4DKF was able, recently, to work ZL1FW, at 1830 G.M.T.

Lately a few D stations have gone to crystal control; D4BY, D4AU, D4ABR and D4CS. The tendency amongst D stations is toward higher powers, and in consequence a few new DX hounds will be heard on the 14,000-kc. band.

GREAT BRITAIN

By J. Clarricoats, G6CL, R.S.G.B.

Conditions on both 7000 and 14,000 kc. were very good during March. This seems to be one of the best months of the year for DX working, and many of our stations have recently claimed to have worked all continents. (We still issue W.A.C. certificates. — A.L.B.) The 14,000-kc. band has been particularly active, for besides the many Europeans who have come up from

(Continued on Page 78)

Calls Heard



VK8CX, Alan G. Brown, 8 Mangarra Rd.,
Canterbury Et, Victoria, Australia

14,000-ke. band

wlanz wlawe wlbld wlbux wleek wlemx wleok wlmr
wlpd wlyf wlst wlxy w2abu w2afj w2afo w2api w2aql
w2afb w2bcp w2bvq w2ch w2cix w2cue w2cus w2euz w2ef
w2gt w2kx w2mk w2ne w2qu w2up w3cee w4aef w5urx
w5kl w6chy w8ahe w8amh w8urx w8azg w8cww w8cvq
w9aas w9che w9cwx w9dqq w9ef w9fa w9fhy ve2ca ve2bg
k19 klaf k1em k6avi k6cij k6dbl k6dpg k6dtg k6sha
au4db d4dba d4yp f8cp f8ct f8tr f8eo f8fd f8sm f8wb
f8xz g5by g5bz g5ma g5ml g5wk g6hp g6qb oh2am su4zf
laig eu2aj pkl1r pkiaz vu2kw vu2kt vu5vx vu2yx vs3ab
file su8an os4th oa4l oa7s lu4dq lu3dh se4ah setaj rxz
yilm yilac yilmz on4fp

7000-ke. band

wipe w2evj w3rd w4tk w5ash w6avj w6ee w7iq w8bau
w8die w8gz w8bqe w9cyx w9gv w9ln w9sb w9u ve2be
klaf klhr klpw yilm yilmz on4fp f8azq f8kp ac8ry
ae9aa xeb-4wx

BRS188, Basil Hall, 25 Coombe Gardens, New
Malden, Surrey, England

7000-ke. band

wiabz wlaed wiaf wiaj wiax wlaoo wlaoo wlaqs
wlavl wiaxx wlibz wibgo wicnp wicqs wlgw wllg
wlsl wisz w2agp w2ajt w2anm w2api w2anb w2aya
w2azk w2bac w2bfy w2blx w2boz w2euf w2vuw w2dk
w2ki w2nt w2rk w2ve w3anh w3aws w3jw w3ld w3mv
w3nr w3st w3ut w3zcc w4aba w4abw w4aef w4agg w4ahl
w4aq w4sd wawe w7mo w8awp w8awv w8bcu w8bt
w8byn w8chd w8rl w8aov w9azy w9dbj w9dek w9dgg
w9fek w9elb w9exw w9ezw w9gau on3af ct2aa fmear58
fm8ev fmsrit hefjg kdv5 kf5 44ae os1da rxw

14,000- and 28,000-ke. bands

wlaao wlabg wlaei wladp wladw wlaed wlaep wlaif
wlahx wlaid wlab wlabz wlapq wlaqd wlaqt wlaie
wlaej wlasu wlavx wlawe wlawm wlaze wlbou wlbkf
wlbsm wlbux wleek wleel wlefi wlejc wlemx wlemy
wlept wlda wldp wlfk wlfz wlia wlkh wlmr wlod
wlpy wlsf wlsv wlvw wlvz wlvz w2abu w2aen w2adb
w2adh w2adj w2adp w2aef w2afj w2ahi w2ai w2aof
w2aog w2aou w2api w2aql w2arh w2ary w2ate w2avb
w2avz w2avs w2bdc w2be w2bhq w2bjr w2bou w2bvq
w2ch w2cix w2es w2evi w2cvq w2fl w2fy w2hq w2hr
w2jn w2jz w2mb w2md w2rs w2ws w3adp w3aaj w3ath
w3bd w3bhm w3bpr w3btg w3jn w3cee w3eq w3jm w3oh
w3ow w3ux w3vg w3vx w4ab w4act w4adb w4aef w4ahl
w4ai w4ajk w4ux w5adm w5afg w5ahe w5ann w5aur
w5axa w5ayo w5azo w5bvu w5chf w5chi w5cpe w5era
w5dff w5dgv w5doa w5duw w5hx w5ja w5kr w5lv w5oak
w5bfw w5bgv w5eki w5err w5eac w5fxj w5ka w5vx aplap
ar5um au7ab au7ap au7au ce2ab ce3ac ce7aa cm2t
cx1ev cx1na flm file fk5er fm8ev fmskik fmsrit intun2 folsr
ivm2 klcm k4akv k4ni lu3dh lu4dq lu9dt nesae nj2pa
pk1r pk4az pylaa py1bl pylca pylcm pylen pyler
py1et py1ib py1id py1tr py2aj py2ak py2bc py2ih py2qa
py3ah sb2sb sc1ah su8an su8ar su8rs velap velar
velhd velbr velco ve2ac ve2al ve2ap ve2bg velbh ve2ca
ve3bm ve3qs vk2aw vk2ek vk2kl vk2lj vk2no vk2rx
vk2tr vk3bd vk3bc vk3ep vk3ex vk3j vk3my vk3ot
vk3pm vk4bb vk5bj vk5bw ve5hg vk5jh vk5wr vk5xz

vk6he vq2bh vslab vsiwb vs3ab vs3gg vt2kt vu2kw
y1lm y2gg z14ab z14ac z14ba zslu zszn zsf4 zslm zsf6
zsd5 zsu5 zsp6 ztlj zt2c zute xpaocp xtaoja zw7eff nki
ozmc rxw

OK-RP18, Henry Rakosnik, Sedlec pod Kaukem,
Czechoslovakia

wlnc wiaxx wlbux wlcaw wlmr wisz w2afo w2ap w2api
w2euf w2exl w2dk w3mv wiaba wiaef w4aqi w4icy w8ahe
w8bk w8cch w8dx w8gz w9asq w9avl w9bdp w9dgg
w9el w9etq w9kly w9xi au7aa au7ab au7ao au7as klcm
ok1az ok1kx ok1na ok1ok ok1rf ok2lo ok2pa ok3nz
ok4qo ve2ac vk3bd vk5vx vo8ae vq2bh vu2kw yilac
yilm yilmz z2mo z4tm

K4ACF, Aubrey C. Levi, 7 Snelge Gade St., St.
Thomas, Virgin Islands of the U. S. A.

7000-ke. band

wlaak wlaed wlang wblf wlbz wlemf wlemp wicpo
wlcq wlcw wleta wlgw wliu wlmk wlrp wlse wlsa
wluz wlwu w2age w2akt w2anh w2apx w2apy w2apx
w2bfi w2bhu w2bhv w2bif w2bo w2boj w2exl w2ep w2uk
w2xg w3add w3aer w3ahg w3aim w3ain w3aks w3au
w3amb w3anh w3arb w3ard w3arp w3awq w3bhx w3bw
w3bl w3mv w3nt w3ut wiae wiaec wiaeb wiaef wiaen
wiazg wighl wiaq wiauf wiaq wibz w4ef w4ed w4ev w4ei
w4ft w4j w4ky w4lx w4oz w4rr w4qu w4to w4ut w4uy
w4evw w4ve w4zo w4zp w4zy w4zcc w4af w4ahb w4ain
w5akp w5amf w5apo w5awd w5ayb w5bzc w5bdg w5hy
w5ld w5mx w5nd w5qq w5sr w5ux w5zav w6afp w6awp
w6bbi w6cu w6eaa w6efc w8afm w8ajt w8amp w8an
w8apq w8ayh w8aym w8awp w8bek w8bg w8bk w8bt
w8cgo w8ab w8cnx w8ddk w8ddq w8dph w8drj w8dyz
w8gy w8i w8le w8lf w8lq w8lv w8uk w9abu w9ab
w9ban w9bes w9beu w9bv w9bd w9bol w9bpd w9bq
w9bx w9bak w9cva w9eye w9db w9dpy w9dzz w9ek
w9etq w9ehw w9fv w9fyp w9gal w9hw w9j w9lk w9qc
w9um w9xi kd5v eb4eu ve2bb kf6 x29a nr2hc kfzu

14,000-ke. band

wialb wibk wibux wleek wldp wlmr wlom wlpm
w2adl w2adp w2ahi w2akg w2alg w2anj w2ayb w2ba
w2be w2bhv w2ip w2pp w2jg w2jn w2up w3atw w3cee
w3jm w3ky w3oh w3oq w3rr w3vg w4act w4acy w4ae
w4afe w4abh w4ajq w4el w4er w4gy w4my w4nl w4oa
w4uv w4ake w5aop w5arx w5av w5brh w5bvu w5ces
w5cww w5eed w5dae w5hh w5qu w5re w5ax w9def w9duz
w9ef w9fy w9giz w9ka ve2ca ef8ct nj2pa ef8sm ear96
ea4ai

KFR5, Walter Berg, France Field, Canal Zone

9000 to 7000 ke.

wlaak wladg wlasx wibat wibea wibgq wibil wibxg
wlcgd wlcml wlcng wln wlmk wterd wlrp wlst wlv
w2aja w2au w2ase w2ate w2baq w2ais w2bda w2bdz
w2beh w2bek w2bhm w2blx w2bne w2bmx w2ban w2cty
w2euf w2euz w2eug w2exl w2eyx w2dg w2gt w2fn w2fl
w2mb w2ov w2qu w2xad w2xaf w2zas w2zi w2zj w3au
w3aee w3aim w3ais w3ajt w3alp w3anh w3b w3as
w3ard w3asa w3auw w3ax w3bel w3bhx w3bn w3bnf
w3bnu w3ez w3lz w3te w4ah w4aa w4ac w4ae w4af w4ah
w4ahy w4ab w4aj w4al w4aq w4ak w4cs w4dt w4ea
w4fe w4fn w4ft w4j w4ky w4mi w4ni w4nl w4px w4qb

wisi w4th w4to w5aak w5aur w5ael w5aex w5ae w5aek w5afe w5afj w5afx w5agp w5ain w5akz w5aaz w5apq w5apz w5aqe w5aqy w5atz w5awq w5ayl w5ayo w5asl w5azd w5azr w5bad w5bat w5bbe w5bbo w5bcm w5bcx w5bdx w5bdy w5bfc w5bea w5bl w5br w5by w5bz w5jc w5kh w5ky w5ux w5ox w5qk w5qo w5qx w5rg w5sp w5tg w5uk w5ux w5vz w5wa w5wf w5wo w5oak w5ab w5abg w5ah w5ahb w5ahp w5am w5aoe w5aaw w5awp w5bdg w5bf w5bhc w5byb w5bys w5bzd w5bzs w5cax w5cbw w5ceb w5cin w5cis w5cjd w5czr w5cux w5cbd w5cdf w5dj w5dkx w5dpo w5dqd w5djq w5drb w5dsg w5deem w5egr w5ele w5fis w5ft w5hc w5lo w5wb w5uc w5ufa w5agb w5azu w5ek w5fe w5kl w5kt w5re w5sac w5sac w5adq w5sah w5sahs w5salu w5saw w5sac w5saz w5sbc w5sba w5sbg w5shj w5sby w5sbd w5sbrl w5sbr w5scau w5scf w5sco w5sco w5scmb w5senu w5senz w5sep w5sepr w5sctz w5sda w5dep w5dfk w5dkx w5dlid w5dmm w5doa w5dnpj w5axa w5diu w5dvm w5in w5ioj w5lf w5li w5lt w5lm w5sp w5ve w5vx w5xe w5agu w5aid w5aio w5ak w5alm w5ama w5anz w5arn w5azu w5ayo w5baz w5bca w5bf w5ajp w5bbz w5bjl w5bju w5bpd w5bpbq w5bpc w5bre w5brx w5brh w5bsh w5ces w5ceg w5cgl w5cia w5emo w5cov w5cph w5cqd w5cub w5cvm w5cwn w5czz w5dhm w5dcew w5dih w5dmm w5dew w5dkg w5dma w5dpy w5dw w5dyl w5dws w5dz w5efe w5efk w5egz w5egu w5ejo w5eme w5eqq w5emn w5eqc w5exw w5fax w5fgy w5fhy w5fid w5fqm w5fs w5fsm w5fte w5fxh w5fxy w5fzs w5gal w5git w5ggz w5ld w5ll w5ln w5lv w5lnk w5lqy w5us 44abg ceear37 ceear98 ceear116 ea-3j ea-1bn ea-1cn eb-4jj ef-2sc ef-8btr em2co em2cf em2fs em5ay em5ni em5fl em5by em7ex em7sh g5by g5nu g5yk ct1aa jct j5dr klaf klcm kl1ab kl1r kl1r kl1p k3aa k3gr k4aan k6bo k6cjs k6czj k6dbi k6dtg k6dv k6dvg k6dqq k6eha k6ekh k6est nj2pa nn1c nn7nic oa4o oa4q spcbl spcm spj1l ve2ap ve3cb ve4df ve5az ve5co ve5go sn3x se2ea se2jm sb1ad vk2ac vk2ak vk2dy vk2fm vk2jn vk2jh vk2lj vk2lk vk2ko vk2jh vk2ns vk2rb vk2rz vk3ag vk3ap vk3ar vk3av vk3aw vk3ax vk3bx vk3gt vk3kj vk3jy vk3la vk4bb vk4hb vk4ra vk5bx vk5gh vk5jh vk5sg vk5wr vk7lj xlg xlf xlj xlc xlr xlt xlfw zfx z1ab z1bg z1bo z1fx z1gaj z1zas z1zaz z1zao

ve1ar ve1dy ve2bd ve4dj vk2lj vk2rx vk2tw vk2aw vk2xr vk3lp vk3ca vk3cp vk3yp vk3pm vk3ct vk4bb vk5bj vk5g xlj x9a yllu ystfm zllao zllax z12ab z14a xj wbtg

W1KD and W1SF, M. I. T. Dorms, Cambridge, Mass.

14,000-kc. band

zllao zllax z12ac z12ag vk7ch vk5gh vk3cp vk4bb vk5a ce3ah ce3ag celah ct1bx ct1by nu2pa vo8ae f8j f8ct f8aap f8pam f8eo f8orm g5by g6rb g6vp g5lw g5wv d4yt oh2nm nr2ea nr2ags xw7eff x9a pk1jr vo8rg oa4h k4aag k4akv k4kd k4agf k4ni z4m k4aan py1ca py2ak py1aa lu4dq oz7g

W2GT, G. B. Angle, 104 Lutigen Place, Linden, N. J.

During April, 1929, 14,000-kc. band

ep1c ex3ah d4aar d4jn ear98 eb4tu efaap f8ar f8er f8fg f8fr f8ra f8ja f8jt f8jv f8jv f8lg f8orm f8ra f8sx fa8bak fmsgt g2p g5bj g5lv g5lp g5wv g5wk g6cr g6hp g6qm g6rb g6uj g6vp g6xn g6wy g6yv kt1 nj2pa on4ar on4di on4ip on4nu pb7a py1aa py1ib velap ve1co ve3hb ve3br ve4dj ve8hx vk3cp vo8ae vu2kw w6abg w6ary w6av w6awg w6drb w6efe w6ju w6gl w6zbb w7acs w7aio w7aja w7li w7ui x9a epa

VE4FV, Don B. Sinclair, 205 Cambridge St., Winnipeg, Man., Canada

January 1st to April 15th, 14,000-kc. band

celah ce2ab ce2ar ce3ag em2jt ct1bx f8ct f8orm f8wb g2ao g5by g5ml g6hp g6pa g6gb g6vp g6yq kfr5 k4akv k4ni k6alm k6clj k6eha nj-2pa nm-bx nr-2ags py1ah pylat pylaw pylib pylid pytem py2aj sa-1xe velap velay ve1co ve1dq ve2aa ve2ae ve2ap ve2ax ve2bh ve2ca ve2ce ve2aq ve2be ve2bk ve2bm ve2bo ve2lp ve2cb ve2cl ve2cs ve2dr ve2dz ve2eo ve2es ve2et ve2hb ve2qs ve2rf ve2rg ve2tm ve2af ve2am ve2et ve2cu ve2db ve2di ve2dj ve2dk ve2dp ve2ek ve2ff ve2fn ve2fd ve2gm ve2gq ve2gx ve2hc ve2hh ve2hm ve2hr ve2hx ve2ic ve2io ve2jb ve2jv ve2jz ve2ak ve2al ve2ax ve2az ve2et ve2ep ve2er ve2ex ve2hw vo8rg x9a xpa0ja zllax z12ac z14ax z14a z11a wiat

W9BGA, E. J. Raible, 819 Sylvia St., Louisville, Ky.

14,000-kc. band

apl ce2ab ce3ac ce3ag ce3bf em2jt ct1by d4yt f8acj f8btr f8ct f8eo f8er f8fd f8fg f8orm f8pro f8rbv f8sm f8so f8wb g5by g5x g5ml g5wk g6rb g6rl g6rw g6vp g6vy g6wy g6xb g6xn g6yq k4akv k4ni k4kd lu2ca lu2fi lu3dh lu4dq lu9dt nj-2pa nl-gren oa4h on4ar on4ip oza py1aa py1ah py1aw py1bs py1ca py1cl py1em py1er py1ib py1id py2aj py2ak py2aw py3ah vk2rx vk3cp vk4bb vk5gh vk5xg xlj x9a z11ao z12ac z12ic z14ba z4m z1r

XPA0JA, Cape Finisterre to Cape Verde Islands

14,000-kc. band

w1aao w1adm w1acm w1ahx w1ajd w1alb w1arx w1asu w1bal w1bnp w1bg w1bms w1bux w1cnx w1opt w2aog w2beq w2bg w2bhq w2bkw w2bvw w2hr w2jn w2mb w2md w2nr w2rr w2rs w2tr w2uc w3adm w3adp w3ahh w3apo w3bwj w3cee w3jm w3ux w3vg w4ef w4ui w4dv w5bbi w5bcx w5bz w5bdk w5brh w5cwr w5cx w5dox w5doa w5jq w5mq w5uj w5bmu w5wz w5wez w5ef w5em w5eva w5evu w5exb w5fhy w5hm dhqa d4yt ear96 f8acj f8btr f8eo f8pam g5by g5bz g5wk g6cr g6hp g6lk g6nt g6qb g6uj g6vt g6vp k1em k4ni paodm paopt paowm paopcp py1ah py1ca py1em py1ep py1ib py1id py2ig py2ii py3ah sc3bf sp3ar ve1co ve2ca ve2bg ve2cs z1lf

(Continued on page 82)

Eugene Mattimore, 247 E. 62nd St., New York, N. Y.

w1ade w1agy w1ajb w1ajf w1aks w1ara w1awx w1axx w1bba w1bd w1bob w1bsn w1caa w1cd w1cdg w1cgr w1cll w1cq w1ei w1eu w1if w1ip w1jk w1kp w1mk w1pi w1rp w1wv w2abs w2ba w2ac w2ag w2ag w2ag w2ahz w2akm w2alu w2amh w2amq w2amt w2anf w2ans w2aoe w2api w2aps w2asg w2asz w2atc w2auk w2aul w2aur w2av w2avq w2avw w2avy w2ayv w2bda w2bfi w2bic w2bkc w2bkw w2bn w2bnw w2bo w2box w2pa w2bpk w2bpn w2bui w2bwe w2chd w2cin w2cou w2czz w2da w2f w2hg w2hn w2hq w2ku w2lx w2np w2nt w2ot w2sg w2vo w2wv w3afj w3afn w3ahe w3amw w3apx w3ard w3as w3att w3aws w3awz w3bq w3bqj w3ck w3ct w3ep w3gf w3kr w3lz w3ma w3mt w3nr w3sn w4agr w4alh w4aj w4ak w4ar w4ca w4cz w4dw w4ea w4ft w4ne w4we w4zp w5ay w5bg w5ib w5sag w5ail w5alq w5aoi w5awh w5ayh w5bbs w5bei w5bts w5bwn w5cbb w5cbh w5cfl w5oss w5ev w5cem w5ddr w5dqk w5dxi w5gz w5ha w5jm w5kr w5lt w5na w5tk w5wz w5baz w5ebw w5efj w5emf w5dzz w5eox w5ewe w5fcg w5fp w5mm w5sm ve2aq

ex-W3ACY, J. Albert Poist, 24 E. Middle St., Hanover, Pa.

7000- and 14,000-kc. bands

w6dqs w6auk w6ebv w6dea w6ajm w6drb w6ban w6dlx w6euh w6dsg w6dsx w6eot w6zbb w6eor w6cxk w6ete w6ebj w6doj w6dtg w6bts w6hb w6uy w6chy w6uce w6ats w6xi w6biw w6eez w6gn w6cyp w6dyo w6bzv w6dsj w6bes w6avj w6ary w6dzd w6eql w6dev w6dew w6ebw w6uf w6gl w6bkw w7li w7li w7lu w7ao aa4si celah ce2ab em2jt em5fl em5bi em5cx ct1by g5by k4kd k4ni kfr5 kfr6 lu3ca lu3dh netdb nj2pa nl1cab nn1nic nn7nic nm5x oa4s oa4o opta py1aa rx4fn va2la velap ve1co ve1co velay

Correspondence

The Publishers of QST assume no responsibility for statements made herein by correspondents



QRM on S. F. Transmission

Editor, QST: Orange, Calif.

Your letter pertaining to O.F.S. and Standard Frequency Transmissions received, and the delay in reply is due to the fact that I wished to make a rather lengthy one, which would require some time and thought.

I have reported on the Standard Frequency Transmissions by card once or twice, and have taken advantage of almost all of them since the service was inaugurated because my meters are used as standards by most of the amateurs hereabouts.

My experience during the transmissions of February 8th were such that I was determined to write you about conditions even before I received your letter. Since then, on the 22nd, the conditions were the same, and I feel that something should be done if it is at all possible.

Most deplorable is the act of a greatly increasing number of amateurs of tuning in the signal of W9XL on their receiver and then attempting to attune their transmitters to their receiver while W9XL's transmissions are still under way on that frequency. At first I thought of fellow-amateur receivers heterodyning my own, but noticed that the majority of the interfering signals were r.a.c., hence not receivers and *the cat is out of the bag!* Some amateurs are just exactly that thoughtless, if not deliberately inconsiderate.

It was only because I have a very selective receiver that I was able to get the transmissions on the 8th through the interference. At times, however, it was quite difficult, especially when W9XL's signals faded badly.

Amateurs continue to work right through the transmissions regardless of the fact that they may be blanketing them entirely for a large number of receiving stations. On a separate sheet enclosed herewith you will find a report on a number of them; their calls should be published. Of course, there is another bunch of amateur stations who continue to transmit right through the Standard Frequency Transmissions and who apparently feel that they are a law unto themselves. I refer to those who are to be regularly found outside the limits of the bands and who, when you mention that fact to them say, "Oh, no, I can't be. W9XYZ says I am right in the middle of the band." They are just precisely the boys who should be spending their time calibrating receivers and meters!

— J. E. Waters, D.D.S., W6EC, W6XE

[The list of calls referred to is not being published, but we wonder how many amateurs can be positive that their call is not included and how many can be sure that theirs is! — EDITOR.]

Atlanta, Ga.

Editor, QST:

For the past three months we have been trying to get the standard frequency transmissions from W9XL, but so far have been unable to obtain enough readings to make a complete curve for any one band for our frequency meters. The whole trouble is that the majority of amateurs care nothing for these transmissions and do not show the courtesy to their fellow hams of standing by during these transmissions. Consequently, the QRM is so bad that even if you hear W9XL he comes through under such a maze of stations that the accuracy of our receiver settings is doubtful.

It is noted that you strongly recommend the use of these standard frequency transmissions, but how can a fellow use them when he can't hear them? Is there not some way that you can persuade these careless amateurs to be decent enough to stay off the air for the short time required for these schedules and let the fellows who wish to keep a good station and abide by the laws use them?

Last night's attempt at getting these transmissions was so disgusting that we decided to get the matter off our chest by writing you, hoping that you could do something to help us out.

— J. W. Sprattin, W4KV

— M. S. Alexander, W4VL

877 Palisade Ave.,
Teaneck, N. J.

Editor, QST:

On the night of March 22nd, I was trying to calibrate some coils from W9XL's standard frequency signals. Due to QRM, I actually got but two readings in the 7000-ke. band.

This morning I copied between 7 and 10 stations, all 1's and 2's, on frequencies between 8100 and 7300 kc. with as many styles of notes. No one knows the variety of gadgets used as modulators.

Conclusion: A very general disregard of standard frequency signals, their use and relative importance; also, a very bland indifference to official frequency regulations.

Antidote: Some pertinent comment on the subject in future QST paragraphs.

— J. A. Woods

"Here at last is The Book that we of the Radio profession have needed for a long time. It is the best and most complete handbook ever published" says J. H. Bloomenthal, Chief Radio Operator, U. S. S. B. Steamship "East Side".

THE RADIO MANUAL

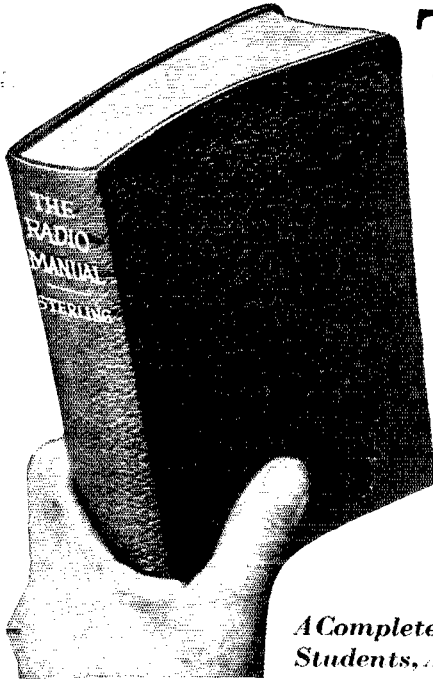

By G. E. STERLING, Radio Inspector and Examining Officer, Radio Division, U. S. Dept. of Commerce.

Edited by ROBERT S. KRUSE, for five years Technical Editor of QST.

Here's the answer to every question about the principles, methods, or apparatus of radio transmitting and receiving. A complete course in radio operation in a single volume. A handbook for students, amateurs, operators, inspectors. For the first time an entire course of training in one book — the most complete and up-to-date work on radio. Developed simply and clearly from the elementary stage right through all phases of principles, practice, and apparatus so that a beginner with no knowledge of electricity may get all he needs either for amateur operation or to qualify for a government license as operator or inspector.

A Complete Handbook of Principles, Methods, Apparatus for Students, Amateur and Commercial Operators, Inspectors

Complete Preparation for Government License.

1. Elementary Electricity and Magnetism
2. Motors and Generators
3. Storage Batteries and Charging Circuits
4. Theory and Application of the Vacuum Tube
5. Fundamental Circuits Employed in Vacuum Tube Transmitters
6. Modulating Systems Employed in Radio Broadcasting
7. Wavemeters, Piezo-Electric Oscillators, Wave Traps and Field Strength Measuring Apparatus
8. Marine Vacuum Tube Transmitters including detailed description of Model ET-3626

9. Radio Broadcasting Equipment including, for the first time in any text book, the complete equipment of Western Electric 5 Kilowatt broadcasting Transmitter used in over 75% of American broadcasting stations
10. Arc Transmitters including description of Federal Marine 2 Kilowatt Arc Transmitter Type AM 4151; also models "K" and "Q"
11. Spark Transmitters including description of Navy Standard 2 Kilowatt Transmitter
12. Commercial Radio Receivers and Associated Apparatus including, for first time in

16 Chapters Covering

- any text book description and circuit diagram of Western Electric Superheterodyne Receiver Type 6004C
13. Marine and Aircraft Radio Beacons and Direction Finders
14. The Development of Amateur Short Wave Apparatus. Complete details of construction, operation and licenses
15. Radio Laws and Regulations of the U. S. and International Radio Telegraph Convention, Quotations of all important sections
16. Handling and Abstracting Traffic

Examine It Free

Never before has so complete a treatment of radio theory and operation been compressed into a single volume. Here is information that otherwise you could secure only by consulting many different books. And every detail is vouched for by authorities of the first rank. The Manual is profusely illustrated with photographs and diagrams. There are 700 pages, bound in flexible fabrikoid that is extremely durable. The immediate demand for so valuable a handbook has already nearly exhausted the fourth large edition. To be sure of receiving your copy without delay, order at once. The volume will be sent for free examination. Pay or return in 10 days.

Order On This Coupon

D. VAN NOSTRAND CO. INC.,
8 Warren St., New York City

Send me THE RADIO MANUAL for examination. Within ten days after receipt I will either return the volume or send you \$6.00 — The price in full.

Name.....

QST 6-29

St. and Number.....

City and State.....

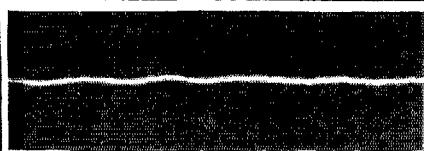

Oscillogram showing noiseless performance of BRADLEYUNIT resistors.



Oscillogram showing noisy performance of other types of resistors.

A New Resistor That Assures Noiseless Reproduction

COMPARE the extraordinary quietness of the Bradleyunit Resistor with the noisy performance of other resistors. Many resistors cause disagreeable hissing noises in the loudspeaker. For pure, clear reproduction, use Bradleyunit Solid Molded Resistors. They are unaffected by temperature, moisture or age.

Follow the example of leading set manufacturers by standardizing on Bradleyunits for grid leaks in detector circuits and for resistors in resistance coupled amplifiers. The Bradleyunit is your assurance that noises in the loudspeaker cannot originate in your equipment.

Write today for data and prices

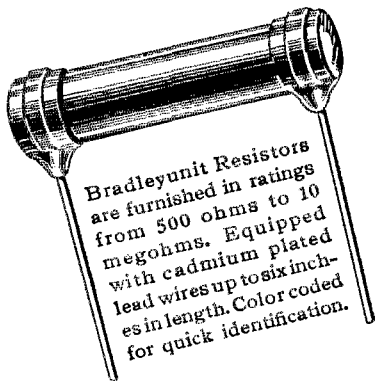

ALLEN-BRADLEY CO.
277 Greenfield Avenue, Milwaukee, Wis.

Allen-Bradley
PERFECT RADIO RESISTORS.

[Letters from the above type are being received in increasing numbers, and are indicative of an unhealthy condition. While it is quite probable that a good deal of the interference with the standard frequency transmissions is unintentional, deliberately tuning a transmitter to a standard frequency during transmission is inexcusable and smacks of malicious interference.

— EDITOR.]

QSL And CQ DX

807 W. Page St.,
Dallas, Tex.

Editor, *QST*:

Here is the way I summarize the QSL problem:

Let those who desire a QSL card or confirmation QSL first, thereby making their wants known. Let every station receiving QSL cards be courteous enough to reply, remembering that there have been times, and there may be again, when they also will appreciate a QSL.

This is a policy that has been in use here for about three years and has proven satisfactory, although even this much QSL-ing would cut the operating time at some of the more prominent stations. However, it secrus to be the best substitute for a perfect policy.

I would also like to say a few words concerning another fault, the usual method of calling "CQ DX." Why does a station call "CQ DX" for 30 seconds before signing? How can you tell whether you are his DX or not before you hear his call? I have wasted many a minute listening to "CQ DX" calls thinking I had a foreign station only to discover some time later that he was in the next district. Of course long calls are at no time in accord with A.R.R.L. policy — but we still have them. Let us at least have the "CQ DX" call broken more often by the station call so we can determine whether or not we would be of interest to the station calling.

— Edw. A. Block, W5AFB

Dividing the Bands

1324 49th St.,
Brooklyn, N. Y.

Editor, *QST*:

As a whole, conditions are better now than they have been in former years. All this talk about being unable to work through the QRM is, after all, just "talk"! The way things sound now, everybody seems to be working somebody else without the least bit of complaint on QRM. Copying is much easier with the new type receiver — so much so that we can consider 1929 with its operating conditions a vast improvement over the 37.5 days.

Our greatest problem, of course, is working through U.S.A. signals to get at the weak foreigners. It simply isn't being done with any degree of success. Early evening QSOs with Europe have been inconsistent and incomplete. It is at that time of the day when DX seems least possible.

〔 "How Use Doth Breed A
Habit In A Man! . . ." 〕

Shakespeare
was right!

"Do you manufacture a condenser of
such and such a capacity? Am building
a transmitter

**HAVE ALWAYS
USED CARDWELLS
AND WANT TO THIS TIME"**

WE get many letters like that, not always in the same words,
of course, but the writers *know* what they *want* and will
not have anything else. They have the **CARDWELL** habit, easy
to get but hard to lose. It will pay *you* to acquire it.

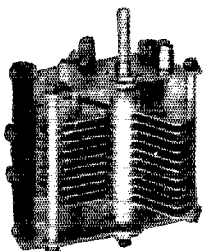

Cardwell Transmitting Condensers will more than
"get you by," they will "get you *there*." Many
types for the big Transmitters, too—Cardwell
Taper Plate Condensers are unbelievably rigid,
and are unequalled for short-wave receivers.

Write for Literature.

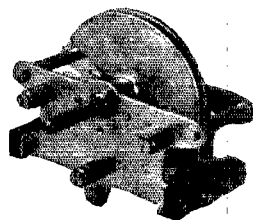

**CARDWELL
CONDENSERS
THE STANDARD OF COMPARISON**



THE ALLEN D. CARDWELL MFG. CORP.
81 PROSPECT STREET BROOKLYN, N. Y.

If your dealer does not stock, order direct.

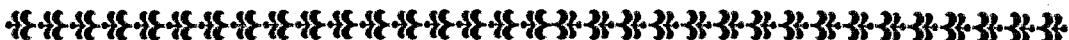



A New Tube & Transformer once more Establish a Brand New Standard of **POWER** **TONE**

No. 994 for use with the new UX-245 Tube

Remember when the UX-250 Tubes came out?
What a Tremendous leap Radio made.

From rasping, indecipherable noise to soft, human reality. Radio critics took a new lease on life; cynics who scoffed at radio became fans over night; and a few set manufacturers, who were first to grasp the significance of the new Volum-Tone standard, became leaders in their industry.

Refinement now begins. UX-245 Tubes are perfected. In the Dongan laboratories engineers have worked, urged on by their own enthusiasm, to develop exactly the right Power Amplifier Transformer as a necessary companion piece to the new Tube. #994 Transformer is the answer. It synchronizes with the Tube — with resulting Power and purity of Tone that delight the most demanding.

The Finest Type of Power Amplifier with UX-245 Tubes use

#994 — Power Amplifier Transformer, \$12.

#2189 — Push Pull Output Transformer, \$12.

#3107 — Straight Output Transformer, \$12.

2 Secondary Windings, one for Magnetic type Speaker and the other for Dynamic type Speaker.

D-946 — Standard Condenser Unit, \$22.50.

This Condenser Unit is also designed especially for use with #994 Transformer for Power Amplification.

#5554 — Double Choke, use in Filter Circuit, \$11.

These Dongan Parts are available now. Equip your receiver with this new amplifier and enjoy still another of Radio's greatest advancements.

*Send check or money order
Further details on request*

Dongan Electric Manufacturing Co.
2999-3001 Franklin St., Detroit, Mich.

"TRANSFORMERS of MERIT for FIFTEEN YEARS"

But even this has its solution. W2CRB suggested that a certain small band, say from 7160 kc. to 7075 kc. and another slice in the 4000-kc. band be set aside for foreign use only. In this way, DX will have a clear channel for U. S. communications.

However, it seems as if conditions are changing naturally. Today, we find our 7000-kc. band divided into the familiar lower and upper edges. Stations on 7300 kc. find it unnatural to work stations on 7000 kc. This is probably due to the fact that our dial readings have been spread out and it takes quite a time to tune from 7300 kc. to 7000 kc. It would require calls of at least five minutes for stations on one end to work stations on the other — and then there is that degree of uncertainty of having somebody else, on a higher frequency call the same station.

There may come a time when the middle of our bands will be almost deserted. High powered stations will find it hard to work DX because DX stations will naturally go to the center of the bands to work U.S.A. (where they will have the most success) and thus cause QRM to U.S. signals in their own country. Foreigners may also shun the edges of the bands because they will find it hard to work U.S.A. through the U.S. QRM. It will be a natural division between the United States and the foreign countries.

One thing, though: Everybody will simply have to get that d.c. note, if we are to have ideal operating conditions.

— Nat Pomeranz, W2APD-2HY

New Ham Comment

Browns Valley, Minn.

Editor, *QST*:

I am a beginner and am using a transmitter that I built according to 1929 principles. On 3500 kc. with the rig tuned according to the Handbook, I have been getting xtal control and d.c. reports.

A UX-210 is used on the oscillator in a self-excited outfit with a UX-281 full wave rectifier and a brute force filter of 30 henrys and 4 mikes. A monitor is in operation continuously both as a frequency meter and signal checker.

I would like to add that I have met a very nice bunch of hams on the air, all willing to QRS for me, and I surely appreciate it.

— Charles Scheifley, W9AMK

The Real Spirit

Georgetown, S. C.

Editor, *QST*:

My detail as Field Artillery Instructor of the South Carolina National Guard is rapidly drawing to a close, and necessarily, a certain part of my activities with amateur radio, as I will not after September 1st, have the time to devote to this very interesting and most fascinating work that I have done during the past four years. However, I am an amateur at heart and will always remain so.

I will never miss an opportunity to be of any

Announcing

a NEW Radio Thrill!

Note: Illustration shows half of shields removed.

TUNED Shield Grid R. F. Amplification from 14 to 500 meters.

The Super-Wasp Kit combines in one receiver Short-Wave AND Broadcast Reception from 14 to 500 meters.

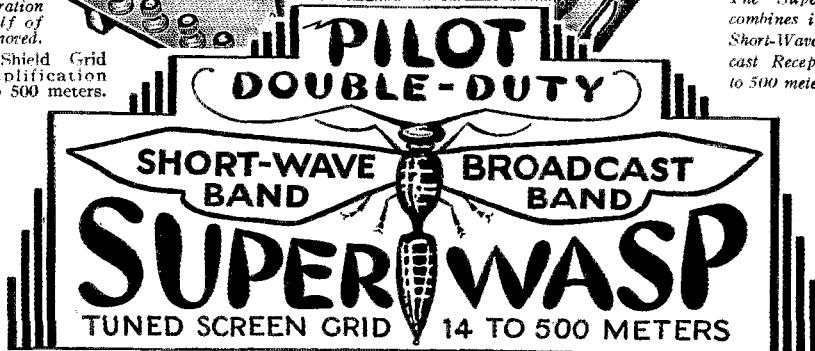

ABOUT THE KIT

The Pilot Super Wasp Kit comes to you complete, with panels and cans accurately drilled and fitted, and with full scale blueprints. Can be assembled in one evening. The short direct leads, required in hooking up, are indicative of its *efficient simplicity*.

The set is completely shielded eliminating all hand capacity effects. The regeneration control, *once set, is consistent over any amateur band*. There remain only two tuning controls — following degree for degree.

A complete set of r.f. and detector plug-in coils comes with each kit, covering all wavelengths from 14 to 500 meters, with a generous overlapping.

On very first test received loud and clear broadcast programs from Chelmsford, England; Costa Rica, Central America; PCJ Eindhoven, Holland; Manitoba, Canada; etc.

"In my opinion no receiver manufactured today is better suited to the amateurs' 1929 need than is the Pilot Super-Wasp." R. S. KRUSE

Not merely a shield grid stage of doubtful value in front of a regenerative detector — but a scientifically engineered receiver with a *tuned* screen grid circuit that provides a gain of from 4 to 20 over the entire amateur spectrum. The SUPER WASP takes the applause out of most "QSA-5" reports.

Selectivity is enhanced without tuning complications. The shield grid stage really TUNES! With this receiver you can unscramble the tones on the 80 meter band. These definite superiorities have been achieved without undue circuit or mechanical complications.

PILOT SUPER-WASP KIT

(Catalog No. K-110) Including 2 sets of 5 coils each, full-sized blue-print and complete assembly data.

\$29.50

Slightly Higher West of the Rockies

PILOT SUPER-WASP FEATURES

One stage of S-G amplification that tunes and amplifies!

Two stages of audio.

14 to 500 meters with plug-in coils.

Two controls over any amateur band.

Completely and individually shielded.

6 v. A, 9 v. C and 135 v. B.

The finest amateur S-W set in the world.

Also a splendid broadcast receiver.

So simple, the beginner can build it.

So effective, the veteran ham cannot afford to be without it.

Send for "Radio Design"

50c brings you one year's subscription to "Radio Design" Quarterly Magazine, chock-full of latest Radio, Short-Wave and Television Developments. "Radio Design", 103-D Broadway, Brooklyn, N. Y.

THE PILOT SUPER-WASP IS MADE IN WORLD'S LARGEST RADIO PARTS PLANT

PILOT ELECTRIC M'FG. CO

323 BERRY ST. BROOKLYN, N.Y. INC.

ESTABLISHED 1908 TRADE MARK REG.



To obtain your radio operators' license—

SEE this book. It contains information essential for all men who are preparing to become licensed amateur and commercial radio operators. It contains hundreds of practical radio questions and answers.

Radio Operating Questions and Answers

By Arthur R. Nilson and J. L. Hornung
Second Edition

267 pages, 5½ x 8, 91 illustrations \$2.00

This is the enlarged second edition of a book formerly published as *Radio Questions and Answers*. It covers the great advances which have been made since 1921 in the art of radio communication; it takes into account the new technique of broadcast-station operation which has been evolved through electrical, mechanical and physical improvements.

Chapters

I. — Diagrams and Explanation of Complete Commercial Transmitter, Receiver, and Auxiliary Equipment. II. — Tube Transmitters. III. — Arc Transmitters. IV. — Spark Transmitters and Transmitters in General. V. — Receiving Apparatus and Radiocompass. VI. — Storage Batteries. VII. — Motors and Generators. VIII. — Radio Laws and Traffic Regulations. IX. — General and Theoretical Questions. X. — Broadcasting Transmitters. XI. — Amateur-Station Operation.

This new second edition covers the latest laws and regulations governing radio operators and the operation of radio stations.

help to our amateur association wherever the chance presents itself.

Words cannot express the pleasure and benefit I have derived from laboring over page after page and copy after copy of *QST*. Your personnel there has done some marvelous work and most certainly deserve the warm praise of every well-meaning amateur in this country and the world at large.

To my idea, the narrowed bands have been a blessing in disguise to the amateur. He must now become a real amateur to meet present conditions and for that he is progressing and not stagnating.

Some of the amateurs are yet slow to grasp the idea but in time I am sure it will come to them as all good things do, by hard work and perseverance.

Let's strengthen our hold on what we now have by striving to get as many of the gang to become affiliated with the Army and Navy wherever conditions are such that we can.

On September 1st, I go back to duty with troops and will take over a battery of Field Artillery, at Fort Bragg, N. C. I intend to still hold on to W4EI and put my station in operation there but necessarily my duties will leave me little time for amateur radio.

— Charles W. Gloner, W4EI

Station Description Contest

R. F. D. 9, Box 69,
Findley, Ohio

Editor, *QST*:

Here's to the Station Description Contest. I hope a good deal of interest is taken in this competition as we all like to see what the other fellow's station looks like and get his idea of what's what. I have referred to this department of *QST* a number of times myself when making or contemplating changes.

— Ross Moorhead, WSARO

A Blessing Disguised

3rd Ave. W., Box 164,
Hanna, Alberta, Can.

Editor, *QST*:

I take this opportunity of expressing my sincere thanks and great appreciation of the truly beneficial work of your technical staff on behalf of the amateurs. The work of these men dispelled the fears entertained by many that the reduced bands would put the ham practically out of existence. The improvement in transmitters has actually widened the band and had the narrow bands been in effect earlier, it is safe to say amateur transmitting would be more efficient than it is even now.

The time is opportune for the A.R.R.L. to take drastic steps to clear the i.e.w., Ford coil, etc. transmitters to the bands where their operation is permitted. There are too many of them on the 7000-ke. band and in view of the circuits developed, to meet the pocketbook of the low power man, there is no excuse for the operation of any-

See it for 10 days FREE—Order NOW

McGraw-Hill FREE EXAMINATION COUPON	
McGraw-Hill Book Co., Inc. 570 Seventh Avenue New York, N. Y.	
You may send me Nilson and Hornung's Radio Operating Questions and Answers \$2.00 postpaid. I will either return the book, postage prepaid, in 10 days, or remit for it at that time.	
Name.....	
Street and No.....	
City.....	
State.....	
Name of Company.....	
Official Position.....	
(Books sent on approval in the U. S. and Canada only) Q.S.T. 6-29	

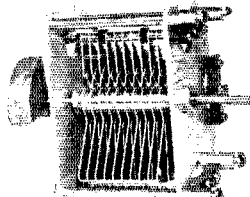

The new General Radio No. 239 Special — double spaced windings; 3500 volts. cap. .00029 — price \$8.00

THORDARSON TRANSFORMER

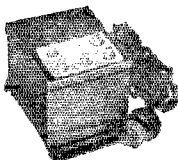

R. 195 Raytheon B-Eliminator transformer, designed as power supply for B-Battery eliminators using the Raytheon B-H tube. Has 2 secondary voltages — low 235 volts either side of centre

tap — high 285 volts either side of centre. Transformer will carry the maximum current consumption of the Raytheon tube without overheating.

Listed at \$7.00 While they last, only **\$2.95**

ACME TRANSFORMER

Listed at \$5.00. The universal transformer for Super Het. 30 K. C. Limited quantity at **\$1.10.**

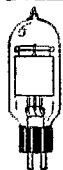
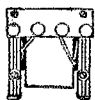

Television Lamp

The large K. H. lamp 4 1/4 inches high — contains 1 1/4-inch plate — carrying 5 to 50 M.A. Special **\$5.50**

LEEDS

The Home of RADIO
45 VESEY STREET
NEW YORK

New York's Headquarters for
Transmitting Apparatus
When in Town Visit Our Store

Everything in
Cardwell
Acme
Thordarson
Jewell
Flechtheim
Signal
Bradley
Tobe
Pyrex
Fleron
IN STOCK



We carry the largest stock of GENERAL RADIO PARTS in the country

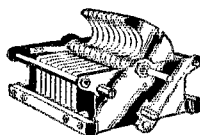

Cardwell con- \$4.45
densers, double spaced for transmitting, .00025 cap.



NEON GLOW LAMPS

Made by General Electric Co., type G. 10, standard base. 101 uses, as illustrated in QST May issue page 17. Price only **.65c**

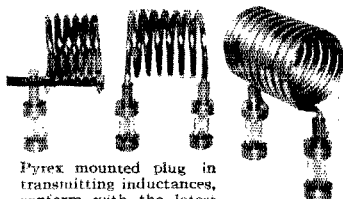

Pyrex mounted plug in transmitting inductances, conform with the latest practice for 1929 transmitters; supplied for any of the ham bands. Coils with mounts for any one band **\$6.50** each coil. Antenna coils **\$5.50** each — Pyrex mounts only **\$3.50** per pair.

Photo Electric Cell



The well known K. H., the most sensitive tube for this purpose — 4 1/4 inches high. Lasts a lifetime with ordinary care.

Never sold for less than \$15. **\$12**
Now Special.

FEATURING

3 new items — Leeds Radio Lab. — others to follow in future issues. This department under the supervision of the Short Wave Specialist Jerome Gross. We design, construct and advise on any material for the "Ham" Broadcasting station or laboratory. Write Jerry Gross for advice on any of your problems.

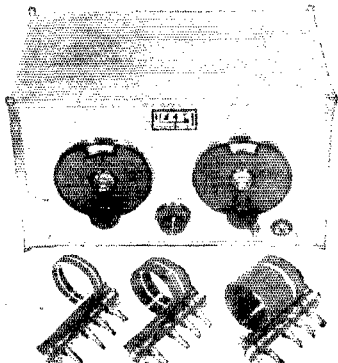

New LEEDS all aluminum plug in Short Wave Receiver. Coils not exposed, thereby insuring 100% shielded job. 2 types, covering ham bands or continuous range, 15 to 100 meters.

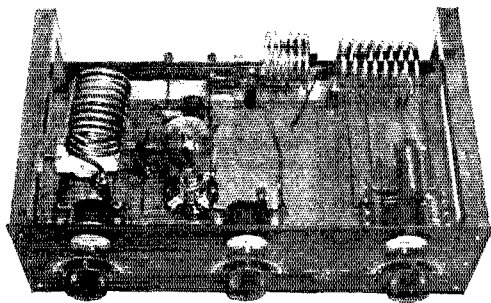

New LEEDS tuned plate — tuned grid, 210 Transmitter. This set contains all the very latest developments in Short Wave transmission. Antenna coupling is variable. Jewel meters employed. In kit form, completely constructed as above or completely shielded.

PLEASE PRINT YOUR NAME AND ADDRESS PLAINLY TO AVOID DELAY

WRITE FOR SPECIAL PRICE LIST

MAIL ORDERS FILLED SAME DAY 10% Must Accompany All Orders

SPREAD THE BANDS

EVERY amateur receiver must spread each band over the entire tuning condenser scale. Modernize your present set by installing the REL amateur coil and condenser tuning combination. Maximum efficiency can only be obtained by using correct LC ratio. Each coil in the REL Cat. Number 182 coil kit is correctly designed to adapt itself to any type of short wave circuit which requires inductances having one, two or three independent windings. The coil shown is one of a kit covering the 14,000, 7000 and 3500 KC bands. The one piece construction means rigidity, insures permanency unattained with any other type of coil. Ask for Cat. Number 182. Price: \$10.00 including three coils and base.

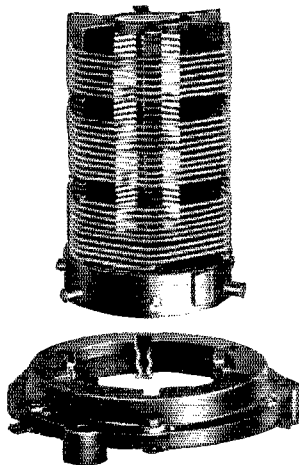

Here is the only variable condenser which will give full spread tuning over any narrow frequency range desired. Its design and construction is far above the usual types now available. It's a receiver condenser constructed more rigidly than most transmitter condensers. Tank capacity, 115 mmfd. Capacity of single plate vernier when spaced 1/16" — 30 mmfd. Ask for Cat. No. 187E. Price, \$6.25.

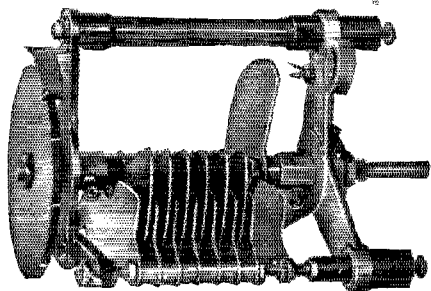

IF YOUR DEALER DOES NOT STOCK
THESE ITEMS. — ORDER DIRECT

REL manufactures a complete line of amateur short wave transmitting and receiving equipment. Write today for your free copy of our new 16 page folder showing latest circuits.

Radio Engineering Labs.
100 Wilbur Ave., Long Island City

thing but what the law stipulates, i.e., pure c.w. on 7000 kc.

Thanking you for the invaluable aid your articles have given me in the past, and wishing the League every success.

— W. P. Roberts, VE4GM

I. A. R. U. News

(Continued from Page 67)

7000 kc. in order to miss the heavy QRM on that band, there are now many long-distance stations using this frequency. Towards the end of the month, South American stations were heard almost every night, from 2100 G.M.T., while earlier in the evening VK, ZS, VQ and AI stations were received.

Very few W stations were heard on this band during the month. A number of ZL and VK stations were heard and several of our low-power stations made first contacts with their antipodes. The 7000-kc. band is being neglected by most of the British low-power stations, who find it impossible to work successfully through the fierce QRM set up by badly modulated phone and raw a.c. stations on the Continent. Many Britishers are refusing to work these stations, and they suggest that all amateurs who have now good notes should refrain from making contacts with them.

It has been noticed that a large number of Russian stations had commenced work on this band. Quite a few seem to have forgotten that a convention was held in Washington recently with the object of stabilizing amateur conditions, as no attention seems to have been paid to the official wave bands or call signs.

At the time of writing, the British 28,000 kc. tests are running. No important contacts are yet reported, but further information will be included in these notes next month.

We should like to draw the attention of our friends who read these notes to the fact that in future the R.S.G.B. will not forward QSL cards to British amateurs who are not members of the Society. Cards for such persons, if delivered to our QSL section, will be returned to the sender. The present membership of R.S.G.B. is 1600, and new members are welcome from all countries. The subscription is 12/6d per annum (\$3.00) and the Headquarters is at 53 Victoria Street, London, S.W. 1.

ITALY

By Ing. E. Montu, Secretary General, A.R.I.

There is very little to report from Italy at the present time. Amateur transmission is held up here for the present owing to the fact that the Italian Government has not yet issued any licensing regulations. This compels us to continue working under cover, and considerably hampers amateur operation.

We hope to secure favorable amateur regulations in the near future, however.

Synchronous Motors for Television

In addition to building reliable and satisfactory motor generators, "Esco" has had many years of experience in building *electric motors* for a great variety of applications.

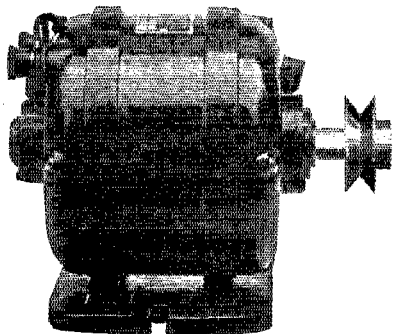

Synchronous motors, small, compact, reliable self starting are now offered for *Television* equipment. They require no direct current for excitation, are quiet running and fully guaranteed.

Other types of motors suitable for Television may also be supplied.

Write us about your requirements.

ELECTRIC SPECIALTY CO.

25 South St.

Trade "ESCO" Mark

Stamford, Conn.

3000 V. Recto Bulbs

Now in stock — 3,000 Volt New Type R3 Rectobulbs. Net price each \$10.00. Also Leach Relays — R.E.L. Products, Omnigraphs — Vibroplexes.

Complete Parts for Silver-Marshall

No. 730 "ROUND-THE-WORLD" 4

A COMPLETE short wave receiver (17.4 to 204 meters) and two-stage audio amplifier. All wave lengths are covered with no dead spots. Amateur bands fall well to center of tuning dial. Net \$30.00. Completely constructed \$38.80. C.O.D. or cash with order. Postage or express extra.

Send for New 1929 Ham Book — FREE

CHI-RAD

CHICAGO RADIO APPARATUS CO.

415 S. DEARBORN STREET

CHICAGO

More Profits To Set Builders

Sports, baseball games, big National events will boost radio business this year. Set builders will reap a rich harvest. Barawik service will make you money. Everything in A-C sets, short wave, television, parts, supplies. World's largest radio stocks on hand. Orders shipped same day. Lowest rock bottom wholesale prices.

Write for Free Radio Catalog and Ham Dope
BARAWIK CO. 116 Canal Sta., CHICAGO, U. S. A.



RADIO INSULATORS

Write for Catalog.

CORNING GLASS WORKS, Dept. 64

Industrial and Laboratory Division, Corning, N. Y.

Raytheon

LONG LIFE RADIO TUBES

The
"Healthy
Tubes"

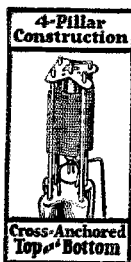
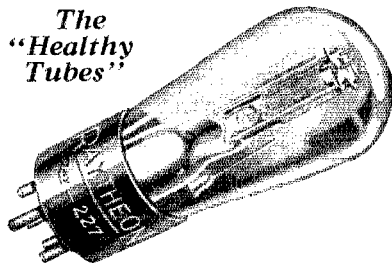

THIS exclusively Raytheon construction prevents premature debility and incidental disorders in radio tubes — hence, the "Healthy Tubes." It keeps the tube elements permanently in their original and correct relative positions.

RAYTHEON MFG. CO.
Cambridge, Mass.

DODGE RADIO SHORTKUT**Kills Hesitation — Produces Results****REPORTS FROM 500 USERS**

telling the complete story and who's who with each order.

Consider the following extracts from reports on file:

- W9ABO—From scratch to 15 per in 3 weeks.
 W9AEB—DRS most valuable aid could find.
 W9AIM—Recommend DRS to all callers.
 W9ALX—Of all methods only one that sticks.
 W9ANO—Discouraged and about to quit game.
 W9BAC—Has it all over old way to get code.
 W9BGL—Stuck at 5 per; one week copied 15.
 W9BHE—Great help in getting code pat.
 W9BHZ—Now copy all can hear. Great help.
 W9BIP—Raised to 20 per; see way to more.
 W9BKX—Great help in gaining speed.
 W9BWW—Long stuck at 5; quickly made the grade.
 W9CEC—Raised speed 15 to 25 in one week.
 W9CET—Speed 12; after few days copied 20 per.
 W9IUZ—Often recommend DRS; fine results.
 VE1AP—DRS for quick results; now O.R.S.
 VE2AC—48 months; 5 per; 30 hours DRS, 2AC.
 VE3EN—Speed 6; raised quickly to 18 per.
 VE4DR—Speed 10; after 2 hours copied 15.

DODGE HIGH SPEED METHOD

(Intensive Speed Practice)

- Most efficient Booster known for 25 per ops.
 W9BFA—Up from 20 to 35 in one week.
 W9CJL—Up from 20 to 35 in few weeks.
 W9DCD—Few hours up from 20 to WIZ solid.

DODGE MORSE SHORTKUTMaster both codes our way and use without mixup.
 W2BXV and W8CJL—Now use both codes without mixup or confusion.

Radio Shortkut \$3.50. High Speed or Morse \$2.50. Money Order. None C.O.D. Foreign add Fifty Cents.

C. K. DODGE**Box 100 Mamaroneck, New York****THE RADIO BOOK**

that has been endorsed and is in constant use by United States Gov't and over 300 Universities, Schools and Technical Colleges in this and foreign countries.

“Radio Theory and Operating”**By Mary Texanna Loomis***President, Loomis Radio College
Member Institute of Radio Engineers*

Fourth Edition revised and enlarged to 992 pages, 800 illustrations and right up to date. Flexible Kraft Leather binding.

Price \$3.50 — Postage Paid*For sale by bookdealers throughout U. S. and many foreign countries, or may be purchased direct from the publishers. Send check or money order to***LOOMIS PUBLISHING COMPANY****Dept. 5 Washington, D. C.***By J. R. Tabley, ZL3CT*

All New Zealand hams are allowed the frequencies 1725–2000 kc., and 3500–4000 kc. After operating on these bands (the first one is not used much) they are given permission to operate on 7000–7300 kc. The idea is to have them gain proficiency in operating their transmitters on 3500 kc., and doing away with inexperienced “lids” on the valuable 7000-kc. band. The 14,000-kc. and 28 mc. bands are not assigned except by special permission, and to get such permission one has to do something extraordinary, viz., work all continents. This is a rotten idea and a big kick will soon be made about it. Raw a.c. and poorly rectified a.c. are supposed to be taboo, but are not in practice. Message handling is strictly forbidden. The maximum power allowed is 100 watts into the aerial. The average input is 20–40 watts, although some go as high as 300 watts.

An annual license fee of £2,2/ (\$9.00) is required.

There are only one or two crystal control stations here so far, but some 3rd district hams are thinking about it. With the new 7000-kc. band, QSO with Australia is easy, but it is harder to work W and other DX than it was on 10,000 kilocycles. There are several stations experimenting on 28 mc.; they are ZL3AR, ZL2AC, ZL1AN, ZL1FT and a few others. Quite a number would go down there if it were allowed.

The N.Z.A.R.T. will probably have branches in the 2nd, 3rd and 4th districts very shortly. The best time to work New Zealand seems to be from 0700 to 1230 G.M.T., which is from about 6:30 p.m. to midnight, New Zealand time.

DUTCH EAST INDIES

From Mr. A. Krygsmann, at Palembang, Sumatra, we learn that there are now about fifty active amateur transmitters on the air in the Dutch East Indies, and that interest in amateur work is very high. The average station seems to use but low powers — 10 to 20 watts, with a few more around 50 watts and one or two as high as 500 watts.

DX is not as much as might be hoped for as yet, but many tests have been carried out with Australian amateurs in duplex telephony, and good results secured.

The Government seems to be favorable toward the amateur, and a special commission is now engaged in studying amateur subjects. It is hoped that a set of regulations in accord with the Washington Conference conditions will be issued before June.

Mr. Krygsmann states that the amateurs of the D.E.I. are now thinking of forming an amateur society for their territory, with the name Nederlandsch Indische Vereeniging Voor International Radioamateurisme, or the N.I.V.I.R.A.

This is splendid; we wish the D.E.I. hams much success in their endeavor, and will be glad to watch the progress of the new organization.

QSL CARDS FREE to Stations using Vitrohm Radio Resistors

Ward Leonard wants all amateur stations using Vitrohm Radio Resistors to have a supply of printed QSL cards — with our compliments.

Twenty-five of the new QSL cards, printed on both sides, ready to use, will be sent free upon request to any station using Vitrohm Resistors. More of the cards if you want them. Send in your request now. There is no charge or obligation of any kind.

New Bulletin 507 Covering Vitrohm Resistors for Radio

A complete line of Vitrohm Resistors for radio receivers and transmitters is included in this new bulletin. Every up-to-date station will want a copy. It will be sent anywhere upon request free of charge.

Ward Leonard Electric Company

31 South Street

Mount Vernon, N. Y.

MORE POWER PER STAGE

Sharper Tuning and No Oscillation Difficulties

Radio Science proves neutralization the only satisfactory method of controlling oscillation in tuned radio frequency circuits, thus increasing actual power per stage of amplification from 25% to 300%

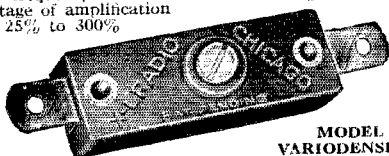

MODEL "N"
VARIODENSER

Apply the Neutrodyne principle to your set by the simple installation of X-L Variodensers. The result is an amazing increase in the efficiency and power of the receiver.

Model "N" has Variable capacity, adjustable from 1.8 to 20 micro-micro tarads, the price each \$1.00.

Model "G" with grid clips made in three variable capacity ranges. Price, each, \$1.50. New Bakelite insulated X-L Push-Post the most perfect binding post made. Plain or all standard markings. Price each 15 cents.

Write for free book of circuit diagrams showing use of X-L Units.

X-L Push
Post

X-L RADIO LABORATORIES

Dept. D 1224 Belmont Avenue, Chicago, Ill.

HILET ADJUSTABLE CHOKES

The use of a variable choke gives the only adjustment in filter circuits, a small lever controls the air gap. Range 10 to 100 Henry, 250 M.A. Size 14 lb. \$6.75, — 100 M.A. 10-lb. \$5.00.

UNMOUNTED TRANSFORMERS

250 watt 500-750-1000 each side midtap, 18 lb. \$8.75; 100 watt 7½-7½ and 325-325, 10 lb. \$5.50; 5-275-275, \$4.00. Specials to order.

Write for complete lists and specifications

RADIO PARTS SALES CO. ORANGE, NEW JERSEY

FROST-RADIO FROST-RADIO FROST-RADIO FROST-RADIO FROST-RADIO

FROST-RADIO

FROST-RADIO MICROPHONES

Unusually sensitive, therefore able to reproduce all audible frequencies with great fidelity. Made in pony arm, hand or desk types, and priced respectively at

\$4.50 \$6.00 \$8.75

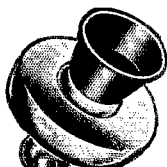

FROST RHEOSTATS WITH D. C. SWITCH

Quick-acting, positive D. C. Switch mounted on Bakelite Panel makes the famous Frost Bakelite Rheostat still more useful. Air cooled frame. Nickel plated metal parts. 2 to 75 ohms. German silver springs have sterling silver contacts. \$1.35 Your dealer has them . . .

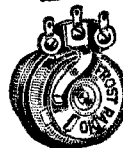
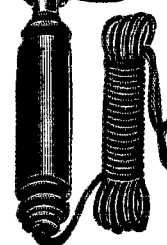
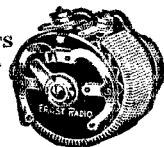

FROST GEM RHEOSTATS

Smallest, neatest, most serviceable little rheostats ever designed. Special design of contact arm insures positive contact. Resistance wire wound on die-cut flexible Bakelite strip. 3 to 30 ohms, \$1.00 less switch, 75c. With D.C. Switch

HERBERT H. FROST, INC.,

Main Office and Factory, ELKHART, IND.
CHICAGO SAN FRANCISCO

FROST-RADIO FROST-RADIO FROST-RADIO FROST-RADIO FROST-RADIO

AEROVOX

BUILT BETTER
CONDENSERS AND RESISTORS

Takes Out the Hum In Any Dynamic

IN spite of the many methods utilized to eliminate the hum in A. C. dynamic speakers, many of the best dynamics still have a hum which is sufficiently pronounced to be objectionable.

You will be surprised at the completeness with which an Aerovox 1500 mfd. "A" condenser, connected across the field coil or across the rectifier output will eliminate the hum and increase the sensitivity of the speaker.

Complete details and comparative data showing the results of using an "A" condenser to eliminate hum will be furnished on request.

A complete catalog of all Aerovox condensers and resistors will be sent free on request.

AEROVOX WIRELESS CORP.

78 1/2 Washington St., Bklyn., N. Y.

PRODUCTS THAT ENDURE

PIERCE AIRO Cardwell Connecticut
Dubilier Westinghouse
THE ACME WIRE CO.
PYREX Westinghouse
Western Electrical Instruments
RADIO ENGINEERING LABORATORIES
Gordon
Raytheon Ward Leonard
Kurz-Kasch
Ward Leonard
Vibrohm
Farrand ELKON
Rajah PARVOLTS
ELKON HOWARD
Knapp
Chicago
TRANSFORMER
CONVERTERS
ELKON
SANDY
PARROT
ELKON
AD. AURIEMA, INC.
Manufacturer's Export Managers
116 Broad Street, New York, N. Y.
Scientifically equipped
to economically export
dependable receiving
and transmitting radio
apparatus

WHDC

(Continued from page 16)

back to Los Angeles. Wherever feasible the expedition will sail up all navigable rivers into the interior as far as possible, pursuing still farther along little known and unexplored rivers by means of Johnson outboard motor-equipped shore boats. In all cases the unusual will be sought rather than the conventional tourist data.

If you hear WHDC don't think it another commercial but give us a "shout."

The New England Division Convention

(Continued from page 13)

emergency. Ensign John L. Ingram, U. S. Naval Reserve, spoke on the Naval Reserve Net Work and what pleasure may be had in enrolling and participating in the work of the Naval Reserve units.

The entertainment feature of the convention was of the best, especially the monologue "The Radio Widow" by Miss Elizabeth Bradshaw, Treasurer of the Radio Club of Rhode Island, who is also an active "Ham." The Eastern Mass. Amateur Radio Ass'n gave a fine musical number with Cooley at the piano. The Providence Radio Ass'n had a session of "Federal Radio Commission in Action." A fine example of Rube Goldberg's imaginative inventions was given by a member of the Radio Club of Rhode Island. (Sorry, om, we lost your name.)

The ball room was filled to capacity when the banquet was announced and after a good dinner. Director Best sprung the surprise of the evening by introducing Mr. Hiram Percy Maxim, our President, who in his inimitable way gave us some sound advice. A very good delegation from the Hudson Division were in attendance and we all appreciate their fine spirit of cooperation.

Most conventions have to come to an end and this one finished with flying colors by the awarding of numerous prizes (too numerous to enumerate) contributed by manufacturers interested in the activities of the radio amateurs. Fellows don't forget to acknowledge your prize.

Adieu until we meet in Worcester in 1930.

— A. A. H.

Calls Heard

(Continued from page 69)

Cape Verde Islands to Santos, Brazil

14,000-ke. band

wiaep wiahx wiaqz wiaub wiaxf wiaxy wibkr wibsg
wicek wlotc wika wizz w2adp w2aiz w2ajb w2aql w2bky
w2bvg w2ch w2euz w2evf w2fp w2xaw w2afh w2jm w2jn
w3vg wiaef wiaii w4dy w4to w4aye w5bbi w6bx w6is
w6dq w6dr w6dz w6ehf w6hh w6l w6lv w6sax w6xa w6bpz
w6rhh w6slq w6za w6agu w6and w6axf w6hen w6hga
w6hht w6hpm w6hch w6ezf w6det w6dex w6esj w6ek
w6frq w6h celas cell ce2ab ce3ab ce3ac ce3ag ce3bf d4qa
ear96 f8aup f8aef f8br f8td f8gdb f8ho f8rbv f8rko f8sm
f8xx g5ly g5lv g5qv g5wk g6bd g6ci g6cl g6er g6dr g6oo
g6uj g6vp g6xi on4fp on4ro pylan pylcm pylcl pyljb
pylah pylba py2ag py2aj py2ak py2bc py2ih py2ii py2qa

BARGAINS ARMY AND NAVY RADIO SUPPLIES

Voltmeter, Westinghouse, No. 492419 cabinet portable, 2 scale 0-5-150, List \$6.50	\$ 2.50	Condensers, Dubilier, mica, transmitting, 8500 volt .004 mfd.	\$10.00
Voltmeter, Weston, No. 267 D.C., 0-70	7.50	Condensers, Dubilier, mica, transmitting, 12500 volt .004 mfd. <i>Prices on request</i>	1.00
Ammeter, " No. 267 D.C., 30-0-40	7.50	Keys, transmitting, Army practice	1.50
" " No. 301 D.C., 50-0-50	5.00	" " Airplane flameproof, silver $\frac{1}{2}$ " contacts	1.50
Voltmeter, " No. 269 D.C., 0-50	7.50	" " with blinker light mounted on bakelite base. List \$7.50 Special	2.00
Amp. hour meter, Sangamo, bat. charge and discharge, type MS 2 sizes, 0-300 and 0-500, List \$50.00	10.00	Keys, transmitting, Navy, 2 K.W., silver $\frac{1}{2}$ " contacts	5.00
Generator, self ex., $\frac{1}{2}$ K.W., 500 cycle, 110 volt	15.00	" " $\frac{1}{2}$ K.W., "Mesco" silver	2.60
Dynamotors, twin, Westinghouse, C.W. 927, 30/750 volt, 0R amp.	25.00	Headphone, Army, with strap, 120 ohm	.75
Dynamotor, Gen. Elec. 12/350 volt, 143 amp.	20.00	" " Navy Radio School type, leather headband, 75 ohm	1.50
Crocker Wheeler, 25/275 volt, external shaft, Sperry Gyro Co., 6/400 volt, 200 watt	12.00	Transmitter, telephone, U.S.N., 30 ohm (used)	.75
Motor Generator, Crocker Wheeler, 110 D.C., 220 A.C., 500 watt, 500 cycle	50.00	Microphone transmitter unit, Western Electric	1.00
Generators, 600 volt, 2 and 5 K.W. Westinghouse and G.E.	\$100 and \$200.00	Magnets, Army mine and ringer type, has 4 large fixed magnets, good value	1.00
Motors, Hamilton Beach, 1/20 H.P. universal, var. speed 110 volt	5.00	Magnets, permanent, U shape, Western Electric, large size	.50
Motors, Edison, universal, 50 watt, double shaft, 110 volt	3.50	Variometers, Gen. Radio No. 107D and 107E, with series and parallel connections	5.00
Motors, Underwood, D.C., 75 watt, double shaft, 1200 R.P.M., 110 volt	3.00	Telegraph and buzzer portable sets, mahogany case, 2 tone platinum contact high freq. buzzer, 2 telephone toggle switches, potentiometer, sending key, 3 mfd. condensers, transformer and 2 choke coils, receiver \$30 value	5.00
Dynamotor armatures, Gen. Elec. triple commutators, two sizes, D.C. 12/750 volt and 24/1500 volt, complete with ball bearings, (build held and save \$30)	\$10.00 and 12.50	Receivers, Signal Corps type B.C. 14A, 200-600 meters, with cry. det. and Century buzzer in portable case	7.50
Transformers, West. Elec. radio, 50,000 ohm impedance, input type	1.50	Receivers, Navy, C.N. 113, 300-2500 meters	15.00
Transformers, Peerless, 120 input, 5-10-15 volt output, $\frac{1}{4}$ K.W., 60 cycle	7.50	" " Signal Corps, 300-3000 meters, with built in tube detector, portable	20.00
Transformers, G.E. current type, 125 to 2500, with center tap, 60 cycle 200 Watt	7.50	Receivers, Marconi, 300-2500 meters, type 106, commercial slip type	35.00
Transformers, Simon, 220 to 11500 closed core, $\frac{1}{2}$ K.W., 500 cycle	5.00	Receivers, Navy, C.N. 240, 1000-10000 meters, S.E. 143 and I.P. 500 <i>Prices on request</i>	50.00
Transformers, Special 250 Primary, 30 taps stepdown, 4KVA, 60 cycle	50.00	Insulators, Elempore, strain 7", 15, 12", 35, 18"	.35
Rheostats, variable, 400 ohm, 3 ampere	.75	" Telephone, Logic, 2-4-6-8 point	.50
Potentiometers, var., 200 ohm, 1.5 amp. airplane type	1.00	" Retardation, West. Elec. No. 57C	1.00
" " 1100 " " "	1.00	Air compressors, Kellogg, Model T, $\frac{1}{4}$ cu. ft. per min.	3.00
" " filament, 1 ohm, 8 amp. airplane type	.75		
Gasoline Engine, 1 cylinder 2 cycle Smith 2 horse power complete	25.00		
Condensers, West. Elec. 21AA 1000 volt 1 mfd, very good value	1.00		
Condensers, Kellogg, 500 volt 2 mfd.	.50		

Largest Radio and Electric Supply House in U. S. devoting eight floors to and specializing on Army and Navy Surplus. Write us your particular requirements. New items are continually arriving. Sufficient postage and 20% deposit must accompany orders. NO C.O.D. ON CANADIAN ORDERS.

MANHATTAN ELECTRIC BARGAIN HOUSE Dept. Q. 105-7 Fulton St., New York City

WANTED

RECEIVERS — Commercial type and wave lengths. Give complete particulars and price.

BECOME A RADIO OPERATOR

See the World, Earn a Good Income,
Duties Light and Fascinating

LEARN IN THE SECOND PORT U.S.A.

Radio Inspector located here. New Orleans supplies operators for the various Gulf ports. Most logical location in the U. S. A. to come to for training.

Nearly 100% of radio operators graduating on the Gulf during the past seven years trained by Mr. Cremons, Supervisor of Instruction.

All graduates placed to date. Start training now for Summer runs.

Member of the A.R.R.L. — Call "W5GR,"

Day and Night Classes — Enroll any time.
Write for circular

GULF RADIO SCHOOL

844 Howard Ave. New Orleans, La.

ROBERT S. KRUSE

ENGINEERING CONSULTANT
for Stations and Manufacturers

103 Meadowbrook Road West Hartford, Conn.

SUPER-POWER STATIONS

Broadcasters, Commercial or Amateur — have but one choice for a rectifier — the Mercury Arc. Rugged, full wave. Current and voltage peaks beyond any demand you may put upon it. Single and polyphase. Filter equipment, 866 rigs. Extraordinary offering of Edison transmitting batteries. Rectifier Engineering Service, Radio W8ML, 4837 Rockwood Rd., Cleveland, Ohio.

POTTER CONDENSERS



THE selection of leading manufacturers for the finest radio receivers. Insure the operation of your radio set or power amplifier with Potter condensers.

T-2900	Condenser Block for the single 250 type tube amplifier	\$20.00
T-2950	Condenser for the push-pull 250 type tube amplifier.	\$22.50
T-2098	Condenser Block for single 210 type tube amplifier	\$20.00
RR-245	Condenser for R-245 Compact for single and push-pull 245 type tube amplifier.	\$19.75
105-05	Interference Eliminator for oil burner and ice machine motors of 110 volt 60 cycle operation	\$3.75

THE POTTER CO.

North Chicago, Illinois

A National Organization at Your Service

HERE IT IS!

June 1929 Issue

With these big features—

WHO'S WHO ON SHORT WAVES

A brand new section, giving frequency, call, and location of commercials, short-wave tones, television stations, etc., heard between 3,000 and 30,000 Kilocycles.

NEW PREFIXES You need this JUNE ISSUE to identify stations heard, new Prefixes, such as D, OA, X, ZS, etc. We have the most complete list published.

NEW AMATEUR CALLS In many countries, due to the adoption of the new Prefixes, lists of amateur calls have been changed completely.

Issued quarterly, March, June, September and December. Single copies \$1.00 each in U. S. and Canada, \$1.10 Foreign. Yearly subscription \$3.25, Foreign \$3.50.

RADIO AMATEUR CALL BOOK, Inc.

506 South Dearborn St., Chicago, Ill.

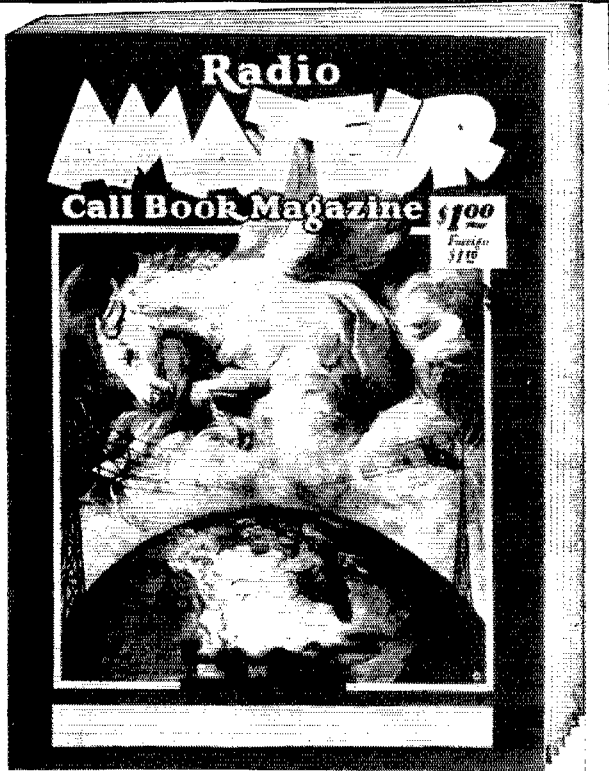

P—A HORNS 80 inches long, 30 inches diameter, of cast aluminum with fibre bell. Exponential type. The exterior is a smooth curve without a break showing. Most graceful horn made. Rugged for professional use, \$60.00, 50 inches long, 26 inch bell, same description as above \$40.00. Two button microphone, standard type, now being used in several broadcast stations. Precision made. Quality and construction second to none. \$50.00. Satisfaction guaranteed.

E. E. PATTEN
5606 42nd Ave. S. W. Seattle, Wash.

Put your voltage control problems up to **ELECTRAD**. Our engineers are yours to consult.

Write Dept. Q6.

175 Varick St., New York, N.Y.

ELECTRAD
INC.

Radio Operators

Raise Your Speed 50 to 100%
in Short Time

Write at once for information about **The Candler System Course in High-Speed Telegraphing and Self-Mastery**—the only "short-cut" to greater speed, accuracy and endurance that mean **BIGGER PAY, DOUBLES** speed of slow operators. Makes fast operators **FASTER**. Takes the kinks out of sore arms. Relieves "glass" arm. Restores the grip. Prevents fatigue, cramps, paralysis and kindred ills. Over 40,000 operators have been developed by this system. **McElroy**, world's champion radio operator endorses **no other system**. Begin now! In a few weeks you'll have more speed than you ever thought possible. Our money-back guarantee protects you. Write now!

THE CANDLER SYSTEM CO., Dept. RL

6343 S. Kedzie Ave., CHICAGO, ILL.

QST OSCILLATING CRYSTALS

Constant Temperature Control Equipment

We are now in a position to supply you with Thermostatically Controlled Heater units for accommodating two crystals (one used as a spare) with provision for instantaneous change-over, said unit maintaining a guaranteed constant temperature to a *tenth of one degree Centigrade*. This unit is easily adjusted and is entirely automatic, operating from the 100-Volt supply mains. Delivery 10 days after receipt of order. Price \$400.00. More details upon request.

We also grind crystals for use in the Broadcast Band accurate to plus or minus 500 cycles of your assigned frequency for \$55.00 fully mounted.

Prices for grinding crystals in the Amateur bands are as follows:

1715 to 2000 Kc band	\$20.00, unmounted
3500 to 4000 Kc band	\$27.50, "
7000 to 7300 Kc band	\$45.00, "

SCIENTIFIC RADIO SERVICE

P. O. Box 86, Dept. E

The Crystal Equipment Specialists

Mount Rainier, Maryland

The NEW Easy-Working

VIBROPLEX No. 6

Reg. Trade Marks: Vibroplex; Bang! Lightning Bug

In Attractive Colors

Fast or slow—the easiest way to send. Easy to learn. Simply press the lever—it does the rest. Now available in attractive colors at no additional cost. Blue, Green, Red and Black..... \$17 Nickel-Plated..... \$19



10 New Features

Blue — Green — Red — Black

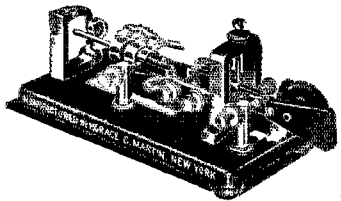

Famous Improved VIBROPLEX

Used by tens of thousands of operators because of its ease and perfection of sending. Colors: Blue, Green, Red and Black... \$17 Nickel-Plated, \$19

Special Radio Model Extra Large, Specially Constructed Contact Points for direct use without relay. Colors Blue, Green, Red and Black.....

\$25

Specify color when ordering

Remit by Money Order or registered mail
THE VIBROPLEX COMPANY, Inc.
 825 Broadway, New York City
 Cable Address: "VIBROPLEX" New York

W8AVS, D. T. Byram, 43 River St., Homer, N. Y.

14,000-ke. band

lu6fc lu3dh lu2bx isaap f8eo f8brh on4di on4ft g6vp g6bd g6vq e5bj g5bz pa0p pa0m ok1rv ce2ab ce3bf py2qa pylaa ktakv up1

7000-ke. band

ct1aa ct1bx ct1by ct1cn ct1bd ct1by ear62 ear122 ear98 ear69 earo ear47 ear116 f8hm f8brh f8axq f8oqp on4dj on4fp on4di on4bn on4fm vk2rf vk3ls vk2rb zl2ac d4dkf k6nl k6avi k6alm k3aan em6ni em5fl em7sh em5ay ne8azw nj2pa v7z xpa0ja

W300, Harold O. Bishop, Front and Edwin Sts., Harrisburg, Penn.

ve3ey w1aby w1aqa w1ayo w1aoz w1aim w1aii w1abo w1bgq w1eki w2aow w2azb w2azu w2ahl w2abz w2ahg w2aca w2aoj w2aed w2ao w2bee w2bs w2bse w2bap w2bma w2bey w2de w2gj w2st w2tl w2ga w2js w3abx w3asw w3aeq w3ckj w3cah w3adg w3bfz w3bm w3mp w3ap w4aev w4agr w4ve w4oa w4pk w5aov w5axl w5ahg w5ajh w5ahz w5adf w5aas w5akh w5bqg w5bxv w5ecz w5exx w5dce w5dxb w5ej w5dpg w5eal w5eas w5hag w5fma w5ewx w5evu w5gwg w5tj w5tvo w5eyv w5gjh

SU2BC, A. Canepa Clerici, Calle Agraciada 2310, Montevideo, R. O. del U.

w1kh w1pm w1za w2brk w2mb w2rs w4aef w5adg w6bes w6ebc w6drb w6eul w6ehu w6ehf w6gnr w6uf w7ajj w8axa w9aji w9bca w9cok w9def w9evu w9ef oa4h oa4s oa4l xw7ef

W3CHP, Joe Krantz, Malden, W. Virginia

ct1aa ce3ac w3ke f8aa f8eo f8mrh hat3an k6alm k7go k7gm lusaq lu4dq nd7ba nj2pa nj2pm pa0fp paogw py1id sclay velap ve4ah ve4go ve4jb vo8rj xpa0ja z4fo fr5

ZL2GO, Harold G. Fomnes, Box 512, Wellington, New Zealand

w1abd w1af w1aif w1blf w1hj w1shr w1age w1ajx w1akd w1alg w1ayo w1aaw w1ca w1ht w1cra w1che w1apk w1btt w1aze w1ky w1ars w1bkm w1blf w2bhh w2aos w2aoc w2at w2bal w2ejx w2aav w2axx w2bvp w2bq w2agr w2ad w2aiz w2ajl w2bia w2brl w2chk w3acq w3aao w3awb w3anq w3atb w3arn w3rlq w3ais w3aoc w3abf w3arr w3kj w3bbw w3bwt w3ahp w3apx w4aiy w4ahr w4aeq w4aah w4ai w4ne w4acc w4tk w4ve w4ur w4aam

W3FJ, Ted P. Mathewson, 24 N. Boulevard, Richmond, Va.

w6eot w6adp w6by w6ben w6bwi w6ab w6eiy w6bdb w6emg w6dfw w6eds w6uj w6dpf w6dyn w6dwp w6tto w6bes w6fe w6dtu w6efe w6dhq w6wb w6kj w6bam w6fk w7akv w7lp w7hx w7ll w7le w7ahx w7pv kdv5 kfr5 k4ni nj2pa f8aap f8agb f8axq f8ij f8ct f8erd f8lgb f8aeq f8xd f8fd on4di on4fp on4ft v5hy g6xv g6vp ear1 ear65 ct1as 55x selah se3bf su2bc pylaa ok1fm vk3cp vk3pa vk3pm vk3lp vk3ml vk5hg

G6YL, Miss R. Dunn, Felton, Northumberland, England

w1awf w1aed w1emp w1epi w1xw w2ahi w2apy w2avb w2bda w2cy w2evj w2eyx w2eir w2ov w2rs w3ar w3pf w4aef w4rb w5aim w8axa w8bu w8dfy w8kv w2px xw7ef frear75 freara frearb cv5af pylcm yillm yi2gm yl2ad yslaa ryle ru2kw ap9frg au7aa au7ab au7ac au7ae au7au au7ba au7kab au7kad au7kag au7kwd veibr ve2ca nx1l nnlnic cm3af 1xr 8ts3 exah gred kgfc rex rwx sdn sdpa sgkn

BRS-186, G. Russell Lee, Opr., 25 Boundary Road, West Kirby, Cheshire, England

w1aeq w1aqt w1alb w1ubx w1caw w1cek w1cjc w2abi w2bei w2bhq w2arb w2fl w2hq w2ku w2md w4cq w4aef w5jm w5fdj w5ef w8axa ve1ar ce2ac vk3ot k1cm ap9frg cv5af au7kaw z4m susan su8rs ce2ab en8mb yillm ok2yd file xw7eff pylcm w2arb w2fl pylaw

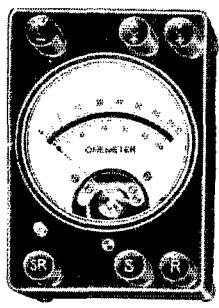

THE "ONEMETER"

Gives six different readings: microamps, milliamps, amps, millivolts, volts and ohms.
 High accuracy — internal resistance, 500 ohms per volt. Contains a double contact safety key and zero adjuster. By the use of the proper shunts the following ranges are obtainable:
 From 20 microamps to 20 amps
 From 50 ohms to 50 megohms
 From 1 millivolt to 2000 volts
 Territories open for reliable jobbers

ROSSITER & COMPANY, Inc.
 136 Liberty St. New York, N. Y.

PRECISION

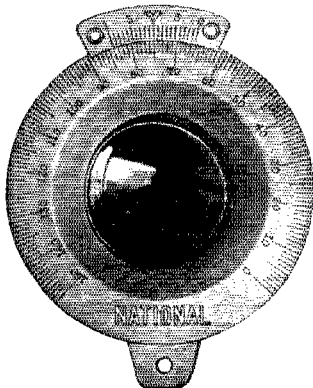

NATIONAL TYPE N

Precision Velvet Vernier Dial

For utmost precision of logging in radio and laboratory equipment. Solid 47th German silver dial and vernier. Reads to 1-10 division. Has the original and unexcelled NATIONAL Velvet Vernier Mechanism — used and approved the world over. List Price, \$6.50.

Send for Bulletin 121-Q

NATIONAL VELVET VERNIER DIALS

National Co. Inc., Malden, Mass.

Radio Operators Wanted

Radio operators are officers aboard ships. Well paid, pleasant work, travel. You can qualify in a short time in our well-equipped school under expert instructors.

Write now for free booklet on "Opportunities in Radio."



WEST SIDE YMCA RADIO INSTITUTE
111 West 64th Street, New York *Established 1910*

QUARTZ OSCILLATING CRYSTALS

Scientifically Prepared for Maximum Power and Unconditionally Guaranteed 1 in. sections, of your approximate specified frequency, supplied at the following prices:

75-100 meters.....	\$15.00
100-200 meters.....	10.00
200-600 meters.....	15.00
1 in. Tested blanks, 200-400, 400-600 meters.....	5.00
Dustproof Bakelite mounts.....	3.00

Sections of any practicable dimensions made to order
Prompt Delivery

J. T. Rooney, B. Sc., 4 Calumet Bldg., Buffalo, New York
"Ten years' crystallographic experience."

"All Experimenters! Here is Your Book at Last!"

EXPERIMENTAL RADIO

THIRD EDITION

By Professor R. R. Ramsey, Indiana University
xii+229 pages, 5½ x 7¼, cloth 117 experiments, 152 figures.
"In general, Ramsey manages to provide that missing fact which seems to be hidden in other books." Review, *QST*, June, '28, p. 80. "This book recommends itself to service men, custom-set builders, testers, and advanced experimenters." *Radio Engineering*. Price \$2.75, postpaid or C. O. D.
Ramsey Publishing Co., 615 E. 3rd St., Bloomington, Ind.

Another New

Amplifier Tube
added to the
advance line of

Cunningham RADIO TUBES

AC Heater Type
Screen Grid Amplifier

C-324

2.5 Volt,
1.75 Ampere

This tube combines the unusual performance obtainable from a screen grid radio frequency amplifier with AC heater type alternating current operation. It is recommended for use as a radio frequency amplifier and as a detector.



E. T. CUNNINGHAM, INC.

NEW YORK CHICAGO SAN FRANCISCO
DALLAS ATLANTA

You supply the specifications — we supply the resistor — in 72 hours

Realizing that most resistors are of a special nature, we have created a new department to facilitate the quick delivery of test samples to your engineers.

Simply send us your specifications, and samples of the exact resistor your specifications call for will be on their way to you within 72 hours.

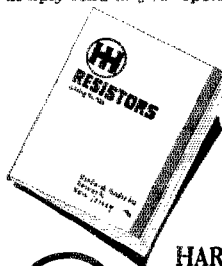

Our new catalog showing a complete range of resistors, mountings and brackets is yours for the asking. Send for it on your business letterhead.

HARDWICK, HINDLE, Inc.

Sales Dept.

122 Greenwich Street, New York City

Factory

215 Emmet Street, Newark, N. J.



RESISTORS



It Teaches the Code!

Learn

Telegraphy with **TELEPLEX**

TELEPLEX is the practical code instructor. Works like a phonograph. Waxed tape records send signals like a real operator. Complete code instructions furnished with every Teleplex. Sends messages, radiograms, etc. — regular code traffic like an expert operator. Used by all leading schools. Endorsed by U. S. Navy. Guaranteed to teach you the code or it costs nothing. Speedy, simple, clear. Ideal for advanced students or beginners.

FREE 10 DAYS TRIAL!

So sure are we that you will be absolutely satisfied with your purchase, that we will let you try it in your own home ON 10 DAYS FREE TRIAL! You are the sole judge. Where can you match that astounding offer? ACT TO-DAY! Write for full facts about Teleplex. No obligation.

TELEPLEX CO., Dept. E12, 76 Cortlandt St., New York, N. Y.

W6QL, J. R. Wells, Box 96, Patton, Calif.

ac8ag ac8ry celah celai cel2ab ce3ac ce3ag f8fd g6ya jlad jlet j3eg j3dd j4zz j9fs klaf kl1em kl1pw k4ni k7aer lu2bx lu2ca lu2ni lu3dh lu3fg lu6fc lu9dt oa4h oa4o py1em py2aj rx1aa vk2ek vk2lj vk2rx vk3bd vk3ep vk3ex vk3ip vk3pm vk4bb vk5hg vk7ch vsiab vs6ab z1tax z12ac z12be z14ac z14ba z50c

VK2RX, H. C. St. John, 82 Gibbes St., Rockdale, N. S. W.

w1ry w2bdr w2bvg w3sh w4wa w5rg w5ahx w6gm w6dwi w6bam w6chy w7mx w8of w8caw w9ef w9che w10vx ar8ufm celah ce2ab ce3ag d4uj eb4ft f8axd f8btr f8et f8gy f8rcm f8xu f8xz g2Xv g5hy g6uj g6wv g5wk g6hp g6qb k6cha oh2nm ok2yd oh2nm paorz suley au8an velbr ac3bf ve2be ve2bg vs3ab xw7eff y1aac

OKRP19, Alois Weirunck, Městec Králové, Czechoslovakia

w1amt w1aof w1bal w1cfl w1cqp w1emp w1mv w1mk w1pd w1sz w1yb w2ach w2bem w2biv w2ekj w2cuj w2evj w2ey w2zxl w2hn w2kj w2ov w3aws w3hg w3pf w3sz w3tr w4ft w4gk w4ta w5adm w5duw xw7eff kl1em k4aan kir5 az7ab au7aa au7ao au7ba au7kad au7kag au7kwd fm8gke fm8rit fntun2 fmear88 y1llm vk2na

WSDYI, D. H. Harris, 715 Deer St., Dunkirk, N. Y.

f8acj f8akj f8axq f8cgg f8cep f8dot f8eo f8er f8fc f8fd f8fo f8he f8jt f8cx f8orm f8pm f8pru f8rh f8sm g2xu g5bj g5by g5bz g5yg g6ge g6qg g6vp g6wy g6xn g6ya g6wv ear65 ear96 ear10 oa4h oh4ang ct1aa ct1bx ct1by paogw paopf paodm on4bt on4nk on4pf ce3ac celah xpaofa lu2ca lu2ul lu4dq lu6fe lu9dt py1aa py1bl py1em py1ld py1qa suley au8rs vo8ae vo8rg x8wb d4abj vk3cp yslau ac3bf cm2jt cm5ll kir5 k4ni k8alm tgb xij x9a nmbx xj w6ac w6ags w6adp w6asl w6atf w6arg w6ary w6awj w6awp w6ax w6ayo w6bam w6bh w6bfi w6bto w6bcs w6bnx w6box w6bsp w6bys w6ejv w6ecz w6dev w6dhq w6dhs w6dks w6dev w6dml w6dpl w6dgr w6dns w6dij w6dpy w6dtj w6drb w6dtu w6dzm w6er w6efe w6eot w6dwi w6dij w6eot w6erm w6eug w6fk w6jn w6kg w6nh w6pu w6sk w6uf w6vz w6wn w7abg w7agb w7ajc w7aja w7aby w7akv w7ah w7ac w7ais w7aj w7alj w7ek w7le w7lh w7hx w7il w7is w7kq w7mw w7ov w7pv w7si w7ui w7si w7un

W. R. Jardine, 264 Buckley St., Essendon, W.5, Victoria, Australia

14,000 and 7000kc. band

w1awe w1bux w1emx w1evy w1fs w1ry w1byl w2ayb w2mb w2md w3avl w1aef w4sh w4zce w5atf w5out w6bbe w5je w5kl w5mx w5th w5ux w6abk w6amw w6aqp w6ax w6bpy w6chy w6ch w6cmv w6cuh w6dxx w6dsg w6drr w6dtd w6dj dbdbn w6eg w6er w6eme w6eof w6fk w6ty w6ell w6dwy w7iz w8dpa w8aoc w8cmv w8cmv w8epa w8ert w8xi k8alm k8cha k8ene k8eck kl1em kl1hr kl1pw kl1z kl1ro k3aa pk4az p5by g5ba sc1ah ac8zw vs3gg az2

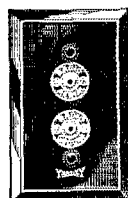

Wire Your Home for Radio

- For every radio need, in brushed brass or Bakelite. Fit standard electrical switch or outlet box. Single plates and in gang in many combinations.
- No. 125 — For Loud Speaker \$1.00
- No. 136 — For Aerial and Ground 1.00
- No. 137 — For Battery Connections 2.50
- No. 138 — For A. C. Connections 1.00

(Bakelite, 25c additional per plate)

YAXLEY MFG. CO.

Dept. S — 9 So. Clinton St., Chicago, Ill.

WHAT
will speed up
MY SET
?



ACTS IN 7 SECONDS

Use **ARCTURUS BLUE** ^{A-C} **LONG-LIFE TUBES**

ARCTURUS RADIO TUBE CO.
Newark, New Jersey

P A C E N T
Duo Lateral
COILS

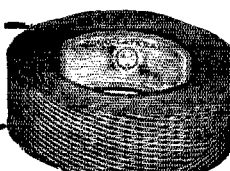

The complete line of all standard turn ratios preferred by leading laboratories and engineers.

Write for information and prices

PACENT ELECTRIC CO., Inc.
91-7th Avenue New York City

SET Builders **FREE**



Barawik, the first and oldest radio specialty house, offers you unusual service this year. Bigger stocks, quicker shipments, lower prices. Deal with an old established, reliable house. Get honest goods, honest service, honest prices. Barawik service makes you more money. Send now for big new catalog showing lowest wholesale prices on sets, parts, short wave, etc.

BARAWIK CO. CHICAGO, U. S. A. 15-A CANAL ST.

FREE INFORMATION NOW READY
WRITE FOR YOURS NOW!

Transcontinental Coils

Gotham Engineering & Sales Co., Nat'l Agts.
50 CHURCH ST., Room 370. NEW YORK CITY

Where Is Your March Issue of QST?

We can't tell you where it is, but it, along with other 1929 copies, ought to be in a

QST Binder

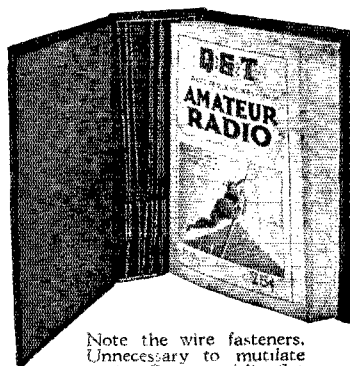

Note the wire fasteners. Unnecessary to mutilate copies. Opens and lies flat in any position.

One-fifty each
postpaid

A binder will keep your QSTs always together and protect them for future use. And it's a good-looking binder, too.

QST

1711 Park St. Hartford, Conn.

National Products Rectobulb

RELIABLE and efficient rectifier tube — low impedance due to mercury vapor — long life due to low temperature filament and oxide coated cathode of large area — of sturdy design which defies the rough handling incident to shipping them.

Normal Rating250 Mils
Normal Plate Volts3000
Filament Amps1.7
Filament Volts10

The accepted standard for Ham Work—of increasing appeal to the Engineer in small Fone Transmitters as used in Patrol Work and Air Service—ideal for Small Broadcasters.

Sent postpaid if cash with order — Safe delivery anywhere in U. S. A. **GUARANTEED**

Price, \$10 each

Announcing repair of UX852\$16.50
We repair 203A tubes\$19.00
204A tubes\$75.00
WE 211 tubes\$16.50
WE 212 tubes\$40.00

ALL REPAIRS FULLY GUARANTEED

National Radio Tube Co.

3420 18th Street San Francisco, Calif.

ACME WIRE PRODUCTS

Coils — Magnet Wire Wound
Magnet Wire All Insulations
Varnished Insulations
Parvoit Filter and By Pass Condensers

All products made to Recognized Commercial Standards including those of:

- National Electric Mfrs. Assn.
- Radio Manufacturers Assn.
- American Society for Testing Materials

For 25 years manufacturers and suppliers to the largest and most discriminating users.

THE ACME WIRE CO.
NEW HAVEN, CONN.

Branch Offices:

- New York Cleveland
- 52 Vanderbilt Ave. Guardian Bldg.
- Chicago
- 842 N. Michigan Ave.

25,000-ke. band
vk3bq vk3de vk3hc vk3ml vk3pm

W1BUX, D. H. Borden, Touissel,
Massachusetts

arSuim celah celai ce2ab ce3ac ce3ag ce3bf ct1aa ct1by
ct1bx ct1by ct1ef ct2ab d4abn d4dj d4lg d4uo d4yt ear1t
ear69 ear9e e17c e18h f8aap f8aq f8axq f8bf f8btr f8er f8ep
f8eo f8er f8faf f8fk f8fr f8gdb f8gy f8ho f8hz f8ih f8ix
f8j f8jt f8kf f8kv f8lbg f8olu f8orn f8pam f8pns f8pro
f8rbv f8rko f8rrr f8sm f8sst f8tsn f8wb f8xz g2qv g5bj g5by
g5bz g5cy g5fv g5ls g5lw g5ml g5mq g5qf g5qv g5us g5uw
g5vl g5wk g5wp g5yx g5bd g5br g5ch g5cl g5er g5gs g5gz
g5hp g5lk g5ll g5nx g5oh g5pa g5qb g5rw g5ta g5uh g5uj
g5ut g5uw g5vj g5vp g5wd g5wi g5wl g5wo g5wt g5wy
g5xb g5xn g5xo g5xp g5yq g5yj g5zd g5zg g5zn lu2ii
lu3dh lu4dq lu6fe lu9dt 4k4kv k3kd k4ni k4sa k4wlm k7ady
oa6q on4ar on4di on4fp on4fq on4ft on4ij on4kn on4re
on4uo xoz7xu nd7ba nq2pa paodw paowim paowr paozf
xpaoja xk1jr py1aa py1aw py1ba py1ca py1em py1en py1er
pr1ib py1id py2aj py2ak py2be py2lg py2ih py2ii py2qa
py3ah x11aa sp3ar su8au ti2as ti2ea vk2aw vk2rx vk2tz
vk3bq vk3ca vk3ex vk3ep vk3jk vk3jo vk3my vk3rx vk4bb
vk4hg vk7eh vo8ae vo8an vq2bh vq2bk x1j x9a z1ao z1ax
z1fb z1fh z1ga z1ge z1gw z1gz z1ha z1ia z1is z1it
z1m z1n z1o z1p z1q z1r z1s z1t z1u z1v z1w z1x z1y z1z

Charles Wilkinson, 79 Gould St., Wakefield, Mass.

w5aa w5ace w5aew w5afg w5ahx w5ain w5alg w5aly w5aur
w5at w5aq w5ax w5ara w5aw w5avx w5awd w5ay
w5ayz w5ar w5ba1 w5bay w5bce w5bcb w5bcm w5bdd
w5bdx w5bh w5bj w5fe w5hy w5jd w5kh w5lo w5mx w5pa
w5q w5qq w5qz w5rd w5rg w5tw w5ux w5ya w5yad
w5bam w5ber w5bt1 w5bto w5bzv w5cui w5ddg w5dgz
w5die w5dbr w5dri w5ddl w5dzt w5dwi w5dyo w5eau
w5eem w5ef w5efe w5ek w5hc w5io w5vz w5wn w7acq
w7adi w7af0 w7a1a w7a1a w7alk w7mw w7ub w7ui w7vk
k1ni em1 em5ac em7sh et1aa et1by et3ab ex3ah ear65
ear9e ear116 efsaap f2nm f8axq f8bl f8cp e8et f8jd f8mat
f8oa f8orn f8pro f8xh g5aq g5bz g5vp g6wy gtix lu3db
nj2pa on4ar on4co on4fp on4ft on4ij paogw pwowem py1be
su8an ve4db ve4dj ve4fu vo8ae z17yp



RADIO IN BRASIL

When in Brasil, apply to M. BARROS & CIA for anything you need in connection with radio.

M. BARROS & CIA

70 sob. Rua S. José 70 sob.
Postal Box 89

Rio de Janeiro

Telegraph address, Radioparte, Rio de Janeiro
Branch: Avenida S. João 4, S. Paulo, Brasil

"The Heavy Duty Giant" POWER RHEOSTAT

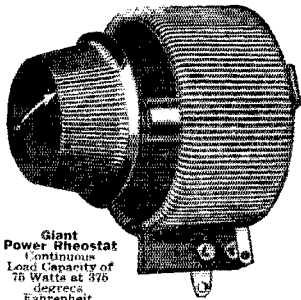

Centralab offers a variable resistance that is capable of handling the greatest power loads under all conditions and is extremely small in size. The Giant Power Rheostat is constructed completely of metal and asbestos — no fibre to warp or burn out under heavy duty use.

The resistance wire is wound on an asbestos-insulated metal core and presents a large area for heat radiation. It will carry a continuous current load through the entire resistance of 75 watts at 375 degrees Fahrenheit.

The mechanical construction is simple but very sturdy, making it an ideal unit for manufacturers. The contact is positive — smooth to the touch and noiseless. This unit is particularly adaptable to primary control of filament transformers for A.C. sets or "A" power supply units to maintain the light socket voltage at a constant average and the secondary output well within rated limits.

The current carrying capacity is so great that it can be used in any radio power circuit without danger of burning out — as the fusion point of the wire is the only limit of capacity.

Made with two and three terminals in resistances from 25 to 8000 ohms. May be had in the 5000 and 8000 ohm size with a fourth terminal for "B" eliminator control.

Priced very low. Wire or write specifications for your needs. Quotations and samples gladly furnished.

CENTRAL RADIO LABORATORIES
18 Keefe Avenue Milwaukee, Wisconsin



To Our Readers who are not A.R.R.L. members

WOULDN'T you like to become a member of the American Radio Relay League? We need you in this big organization of radio amateurs, the only amateur association that does things. From your reading of *QST* you have gained a knowledge of the nature of the League and what it does, and you have read its purposes as set forth on page 10 of this issue. We should like to have you become a full-fledged member and add your strength to ours in the things we are undertaking for Amateur Radio. You will have the membership edition of *QST* delivered at your door each month. A convenient application form is printed below — clip it out and mail it today.

A bona fide interest in amateur radio is the only essential qualification for membership

RADIO OPERATORS WANTED

THE EASTERN RADIO INSTITUTE can train you quickly and thoroughly because:

MODERN AND EFFICIENT METHODS
THOROUGH INSTRUCTION under staff of LICENSED COMMERCIAL OPERATORS
MODERN APPARATUS including SHORT WAVE TRANSMITTER

SIXTEEN years a RADIO SCHOOL
THE OLDEST, LARGEST and MOST SUCCESSFUL school in New England, RECOMMENDED BY THE A. R. R. L.

Day or Evening Classes Start Every Monday
SPECIAL CODE CLASSES

Write for Illustrated Prospectus

EASTERN RADIO INSTITUTE

899 BOYLSTON STREET BOSTON, MASS.

Do you know that the 1929 Handy and Full Handbook is available in bound form — \$2.00 per copy, postpaid?

When ordering a copy of this new edition, look at your present copy and determine if you want the 1929 copy in more permanent form.

TRANSFORMERS

Guaranteed — Mounted — Complete

250 watt	550 — 700 each side	\$10.50
700 watt	1000 — 1500 each side	14.50
700 watt	2000 — 2500 each side	21.00

Chokes, Polyphase and 25-cycle Transformers
Add \$2.00 for fil. winding

9CES FRANK GREBEN

1927 So. Peoria Street, Pilsen Sta. Chicago, Ill.

AMERICAN RADIO RELAY LEAGUE
Hartford, Conn., U. S. A.

I hereby apply for membership in the American Radio Relay League, and enclose \$2.50 (\$3 in foreign countries) in payment of one year's dues. This entitles me to receive *QST* for the same period. Please begin my subscription with the issue. Mail my Certificate of Membership and send *QST* to the following name and address.

Do you know a friend who is also interested in Amateur Radio, whose name you might give us so we may send him a sample copy of *QST*?

Thanks

HAM-ADS

(1) Advertising shall pertain to radio and shall be of nature of interest to radio amateurs or experimenters in their pursuit of the art.

(2) No display of any character will be accepted, nor can any special typographical arrangement, such as all or part capital letters be used which would tend to make one advertisement stand out from the others.

(3) The Ham-Ads rate is 15c per word, except as noted in paragraph (4) below.

(4) Remittance in full must accompany copy. No cash or contract discount or agency commission will be allowed.

(5) Closing date for Ham-Ads is the 25th of the second month preceding publication date.

(6) A special rate of 7c per word will apply to advertising which, in our judgment, is obviously non-commercial in nature and is placed and signed by a member of the American Radio Relay League. Thus, advertising of bona fide surplus equipment owned, used and for sale by an individual or apparatus offered for exchange or advertising inquiring for special equipment, if by a member of the American Radio Relay League takes the 7c rate. An attempt to deal in apparatus in quantity for profit, even if by an individual, is commercial and takes the 15c rate. Provisions of paragraphs (1), (2), (4) and (5) apply to all advertising in this column regardless of which rate may apply.

PLATE POWER for your set, the very heart of its performance. For quietness DX ability, life-long permanence, absolute dependability, lowest ultimate cost, no other plate source even approaches the achievement of an Edison steel-alkaline storage B battery. Built painstakingly, every joint pure nickel, upset electrically welded. Genuine Edison Electrolyte. Our list describes complete batteries, construction parts, enameled aerial wire, silicon steel. Available immediately, filament and plate transformers for the new 866 rectifier, complete plate power units, Rectifier Engineering Service, radio W8ML, 4337 Rockwood Road, Cleveland, Ohio.

THE most complete line of modern short wave receivers for every particular service. Four to nine tube designs. Radiophone-CW transmitters, of any power or type. We make a complete line of apparatus including speech amplifiers, filter coils, transformers, rectifiers, variable condensers, inductances, etc. Any special apparatus, designs, made to order using your parts if desired. Prices on request. New bulletin lists complete line of apparatus. Write for copy. Ensmall Radio Laboratory, 1208 Grandview Ave., Warren, Ohio.

IMAGINE an organization with over 4,000 clients scattered throughout the world, all radiowave dealers, builders, experimenters, hams. Over \$50,000 stock of high grade receiving and transmitting parts only, no sets. Spend \$5,000 yearly on our own experimenting. Carry nothing until it passes our tests. 50c brings prepaid over four pounds catalog, circuits, data, etc.—Weekly data (more than all radio magazines together)—20 weeks—\$1.00, 52 weeks—\$2.50. Sample "Over The Soldering Iron," 32 page experimenters' magazine—25c. Full trade discounts to licensed hams and radiowave builders. We carry approved items advertised in radio. Kladag Radio Laboratories, established 1920, Kent, Ohio.

SPECIALLY made rectifier aluminum with small percentage copper, stand more amperage, last longer, square foot \$1.25. Lead \$1.00. Elements, holes punched with bolts and nuts, new kind 1" x 4" 15c, 1" x 6" 17c, pair prepaid. Best Silicon steel .014" cut to order 25-35c lb. Postage extra. Geo. Schulz, Calumet, Mich.

PANEL engraving—finest workmanship on radio laboratory apparatus. Request price list. A. L. Woody, 19 S. Wells St., Chicago, Ill.

QSL cards, 40c per 100, samples, Radcliffe, North Sacramento, Calif.

I HAVE the complete collection of the magazines: Radio, Radio Broadcast, Radio News, Popular Radio, Wireless Age, QST from 1922 till now. I will sell either together or separately and by year. H. Rabezzana, Flint, Mich.

SELL: Aero TPTG transmitter. Two tube Crosby receiver. Best offer gets them. W3VN Frederick, Maryland.

SELL—National .00015-.00023, Thordarson 150W fil; Jewell 0-15 A. C. minus glass; section REL, type L; three tube SW iainus one a.f.t.; blue racer. Offer. WIAHT.

1,800 watts on 500 watt power xmitter working 14,000 kc., complete with power apparatus tapping domestic supply single phase 220 volt a.c., also tubes, monitor, wavemeter, receiver, etc. Hams selling out please favor Charles Burion Bella Vista, F.C.P. Province of Buenos Aires, Argentine Republic.

IN Stock: Mercury vapor Rectobulbs \$10; Xtals, 85 meter with holder \$15; GE 31's 95c; 99.6% aluminum 70c sq. ft.; Jewell, Lecher, REL, Ward Leonard, Signal all 25% off. Thordarson and Sangamo 30%, Tobe and Flechtheim 35%. Prompt service. Write for anything.—R. E. Henry, W9ARA, Butler, Mo.

HAVE a few odd radio parts for sale. Write for list. W8DDK, Delaware, Ohio.

BARGAIN—radio service man's tester and tool case, tests sets, tubes, power units, line voltages, and provides necessary space for all tools. One omnigraph. Arthur W. Priebe, Chamberlain, S. Dak.

SELL or trade, trapdrum outfit \$70 value, almost new. Wamp typewriter, shortwave screengrid four receiver. Geo. Trostle Sibley, Iowa.

TWO Radiotron 203s, unused, \$16 each prepaid. Louis Hass, W9BBY, 934 Walnut St., Racine, Wis.

EXTRA apparatus, fifteen watt ione with speech amplifier, filament supply and four Jewell meters, \$50. \$50 volt Westinghouse motor-generator with rheostat, \$45. W9GCY, Litchfield, Ill.

WANT all QST's years 1915 and 1916. State price, W9APM, Des Moines, Iowa.

ALL-purpose superheterodyne parts. We build or repair the QST March 1929 set. Get our prices. Shortwave sets our specialty, transmitters and receivers. Hatry & Young, 126 Ann St., Hartford, Conn.

OMNIGRAPHS, teleplexes, transmitters, receivers, vibroplexes, meters, 50 watters, "E" tubes, motor generators, dynamotors, superdynos, converters. Bought, sold, traded. Ryan Radio Co., Hannibal, Mo.

CONDENSERS used—G.E. vacuum treated, sealed in oil, 3000 AC 10 mikes, 35 lbs. 13" x 12" x 3", list \$95.00. A He-man maker for high power outfits. Interested in 204A or cash. Make offer. S. W. Lang, 799 Tyler St., Pittsfield, Mass. W1AZD.

A TREATISE on The Location and Correction of Radio Interference. 75c. Lee Book Company, Box 292, Sta. A, Dallas, Tex.

WANTED: Thordarson wireless transformer, type R, 1kw, 25,000 volt. State condition and price. C. W. Gartlein, Rockefeller Hall, Ithaca, N. Y.

LOWEST price on Polymet transmitting filter condensers, 1000 d.c. working volts, 2 mid. brand new, compare this price, \$2.15 each. W1AOZ, Woodrow Darrow, Waterford, Conn.

TUBES, unconditionally guaranteed. Type 866 \$5, 281A (mercury vapor) \$6, 281 \$4, 210 \$4.25, 250 \$5, 245 \$2.50. You may try any of our tubes for ten days and return them. Vacuum Tube Exchange, 954 Slocum Avenue, Ridgefield, New Jersey.

SELLING out: High frequency four tube screen grid type receiver. See QST November 1928 issue Page 9. Completed less than month ago at cost excess \$100.00. Tested and sure a bearcat! Practically all countries copied without aerial or ground. Aluminum shielded and encased in beautifully finished solid mahogany cabinet. Complete with tubes, storage battery, 135 volt "B" battery and Baldwin phones. All brand-new, \$60.00 takes all. Money back if not as represented. A real job! Robert Leighton Travis, W6MR, 4456 Lockwood Ave., Los Angeles, Calif.

45% off list on Pilot parts for all amateurs, set builders, servicemen. Write for Pilot catalog or order what you want. We ship postpaid on cash orders. Get our prices on Weston, Yaxley, Tobe, Electrad, Hammarlund, Signal, Frost, Sangamo, National, Acme Wire, Insuline, Durham, Ward Leonard, Elkton, Sterling. Five prong tube bases 6c. Hatry & Young, 126 Ann St., Hartford, Conn.

QST cards, two colors, \$1.00 per hundred. Free samples. W8DTPY, 257 Parker Ave., Buffalo, N. Y.

HAVE a few Jewell and Weston meters left. Service man's special (d.c.) 1000 ohms per volt with readings 0-10v, 0-100v, 0-500v, 0-1000v. External resistor, \$15.00. Also 0-2000 voltmeters, d.c. with external resistor, \$13.00. Write for complete information. M. Leitch, Park Drive, West Orange, N. J.

3000 Volt 6000 Watt double commutator motorgenerator, 10 Hp. 3-phase drive \$685.00 complete. 500 Cycle 1 KW. ball-bearing motorgenerator, 110V. DC drive \$225.00, 200 Cycle 1 1/4 KW. ball-bearing motorgenerator 110V, DC drive \$225.00. 2-5 KW. Rotary Spark Gap 110V, DC drive \$45.00, 1000 Volt 200 Watt Esco 1-phase drive \$75.00, 750V, 250 Watt new General Electric motorgenerators \$32.50, 200 Watt \$42.50, 32 Volt drive motorgenerators 750 Volt, 150 Watt \$37.50, 200 Watt \$45.00, 300 Watt \$65.00, 400 Volt 100 Watt generators \$8.50; 1/2 Hp. 3450 speed motors \$8.50; repulsion induction motors \$10.50. Converts 32V. DC to 110V. AC. 300 Watt \$35.00, 110V, drive 500 Watt \$65.00. Large stock plate and filament generators. Queen City Electric, 1734 Grand Avenue, Chicago.

GET list on bargain spectacle 500 watt station selling out, guaranteed dependable high power apparatus. W. Ryder, Hibbing, Minn.

QSL cards, stationery, message blanks, wall cards, high voltage signs. H. Selden, Cranestville, Pa.

HAMS: Get our samples and prices on printed call cards made to order as you want them. W9APY Hinds, 19 S. Wells St., Chicago, Ill.

SELL Two 220-B Western Electric 5000 Watt water cooled tubes each \$150.00, six months active use; One 212-D Western Electric 250 watt tube \$45.00, four months use; Three Western Electric Microphones each \$58.00. One complete set of 1923 Aero Transmuting and receiving coils \$6.00. Station WEMC, Berrien Springs, Michigan.

TRANSFORMERS—100 watt, 110 volt, 60 cycle, 750 volts each side center tap, one 7½ volt center tapped filament winding—\$7.25. Same as above but with two filament windings \$8.00. The above will operate two 210 tubes. Same as above but 150 watt for operating two 250 tubes—\$9.25. All mounted. We supply to specifications any size transformer or choke for amateur or broadcast stations. Scott Coil & Transformer Co., New Albany, Mississippi.

SELL—1929 Hartley 7½ watt DC sigs. DX guaranteed. Proof and description on request. H. W. Bartsch, Marlboro, New York.

TRADE imported sextant or Ross 303 calibre rifle for 50 watter or large tube. H. K. MacLeod, Seaford, N. Y.

NEW UV217A, \$17. **NEW 217C**, \$23. Unmounted, 1000-volt condenser, 2 mfd., \$1.50; 3¼ mfd., \$1.85. Freshman 375-volt two 7.5 volt center tapped windings, \$2.75. Thordarson 220 and 285 center tapped transformer, \$1.95. Microphone cases, \$2.25. C. P. aluminum, \$.70 sq. ft. Signal Corps 3 16" silver contact keys, \$.95. Grebe CR18, \$35. RCA 210 tubes, new, \$6. UV866, \$12. New rectobulbs, \$10 prepaid. 294W microphones, \$4. Sengamo 00025, 001, .002, 5000-Volt mica condensers, \$1.60 each. 30 Henry 150-mill chokes, \$1.90. Signal high frequency buzzers \$.95. Aerovox 5000 ohms grid leaks, \$.40. Used Mercury arca cheap. New Flechtman 1500-volt pigtail leads: 1 mfd., \$3.50, 2 mfd., \$4.50, 4 mfd., \$6.50. Westinghouse aeroplane 275-Volt generators, \$6.50. Guaranteed UX210, same size plate as UX250, \$4.50. One REL Wavemeter, list \$22—special \$12.50. New Paenat phonovoxes, \$7.50. Amateur call books, \$.85. New UX852, \$28. Used, \$20. Thousands of other buys. Send for monthly ham sheet. We want transmitting tubes. What have you for sale or trade? David L. Marks, 125 Madison Ave., Albany, N. Y.

RECEIVER \$12. Extra transmitter, parts, plug-in coils. Louis Berkowitz, 849 Blue Hill Ave., Boston, Mass.

RELAYS, use them to solve your keying troubles and to rig up a break-in system. Has good strong tungsten steel contacts that will break plenty of volts. Get yours now, \$2.00 prepaid. Here's a Bargain—RCA UX 213 B full-wave rectifier tubes. One of them will take the place of bulky Kenatrons or chemical rectifier. Provides enough "juice" for a 7½ watter. Brand new, \$1.95. Don't pass it up. Mitchell Radio Company, 635 Waveland Ave., Chicago, Ill.

OMNIGRAPH, five dials, extra set, complete with key, buzzer 18,000, new Jewell meters. Thermocouple ratings 3, 5, 10, 15, amperes. Alternating voltmeters 15 volts. Direct voltmeters 15, 1500 volts. Alternating ammeters 5 amperes. Direct milliammeter 300, 500, 1000 milliamperes 40% off list. Gordon Brown, 192 South Goodman, Rochester, N. Y.

POWER transformers, choke coils built to order. Transformer iron cut to size. 014" silicon steel, 22c per lb. Stock sizes shell type core laminations. Send 25c for samples. Special, 500-0-500, 7½ V, mounted transformer, \$4.50. Transformers and chokes for transmitters, power packs for electric sets and power amplifiers. Repair and replacement service. Send for catalog. Electrone Lab., 834 N. Randolph St., Phila., Pa.

SPECIALS—accurate panel meters 0-100, 0-400 milliamps, \$1.15, 0-15 volt AC \$2.35, GR wall insulators 19c. Write your needs. We have everything. Anything built to order. New Teleplex, \$20. Will buy all your surplus parts. Finch Radio Laboratory, W8GE, 100 Grove St., Syracuse, N. Y.

AMAZING screw-holding screw driver! New patented invention! Removes, inserts screws instantly, in inaccessible places. Sells \$1.50, 100% profit. Factories, mechanics, garages, electricians radio buy on sight! Exclusive territory. Jiffy 1084, Winthrop Bldg., Boston, Mass.

SELLING out—UX852 \$20. Mueller 150 watt input tube \$10 both slightly used. Two UX281's new \$8. National variable 100 mmfd. 6000v. \$6. Willard storage B's 325 volts for \$16. Mercury arc GE 40525 6600v. plenty nuls new \$15. GE repulsion induction motor ½ H.P. 1800 rpm \$20. 110 v. 60 cy. motor generator 700 cycle 200 w. nice job, perfect condition \$20. Na-Ald Tru-phonic 3-stage quality audio \$8. RCA UP-1016 750 watt power transformer like new \$13. Pat Shultz, W5AQQ, Chickasha, Okla.

DON'T let our amazingly low prices give you the false impression that our merchandise is not of the highest quality. Everything tested and guaranteed perfect. Power Chokes. Complete with core and mounting. 30H, 100MA—\$1.75. Double coil—\$1.95. 50H, 150MA Duddo-wound—\$2.40. 5H, 2½ Amp.—\$4.85. ½" Heavy Copper-tubing inductances. 3" diameter—10c per turn. 4"—13c. Triple-plated with pure Silver. Lacquered. 3"—20c. 4"—40c. 3-coil sets for TP-TG. Mounted on GR standoff insulators: 20 Meters—\$3.25. 40 Meters—\$4.50. 80 Meters—\$5.50. 160 Meters—\$6.75. Silver-plated: \$5.25; \$6.50; \$7.50; \$8.75. CX-250's—\$4.75. Hammarlund 3000 Volt, 0004 Variable condensers.—\$7.95. Manufacturer's type 2Mfd., 400 Volt (Working) Quality Filter condensers—47c. Pure rectifier elements: Low copper-content aluminum. Cut, drilled, bolted, complete. Per Pair: 1 x 4—9c, 1 x 5—10½c, 1 x 6—12c. One inch wide lead strip—7c per foot Aluminum—See "Quick Service". Send for "Specials". William Harrison, 35 Ft. Washington Ave., New York City.

IMPORTED transmitting tubes, power transformers. Write for our free list, Nassau Radio, Seaford, N. Y.

SAMSON PAM—16 public address or phonograph amplifier, practically new, perfect condition. Cost \$125 first money-order \$60 takes it. W5AQQ, Pat Shultz, Chickasha, Okla.

THORDARSON 650-volt power-filament transformers for 7½-watters \$6.90. 1000-1500-volt power-transformers \$16.00. 550-750-volt power-transformers \$13.00. Potter Condensers: 1-mfd. 2000-test voltage \$2.50; 1-mfd. 2500-test \$3.25; 2-mfd. 1000-test \$2.50; 2-mfd. 2000-test \$4.00. 7½-watters \$5.25. Aluminum square-foot 85c; Lead square-foot 85c. "Ham-List" 4c. Curtis Sales Company, 1109 Eighth Avenue, Fort Worth, Texas.

SELL: New 203-A \$28; new 204-A \$70. Sell or trade: 203; WE 250 watter; Advance sync: 12-400 volt dynamotor; new Leach relay; 85 and 170 meter crystals; plate transformers; 400 volt mg. Other apparatus. What do you need?—W9ARA, Butler, Mo.

TRADE or sell—radio parts. Colt 38 revolver, Winchester 38 rifle, IA Kodak, Oliver typewriter. What have you? W6EKK.

FOR sale—5 amp. Westinghouse watt hour meter. Good condition, \$4.00, 10 amp, ditto, \$4.50. Both 110 volt. Guaranteed to be accurate. Ostermeier—W8CHN

TRANSFORMERS made by G.E. guaranteed to deliver 1 kw. at 1100, 2200, 4400 volts each side c.t. for \$12.00 F.O.B. Detroit. Used by Naval Reserve and Colleges. F. G. Dawson, 5740 Woodrow Ave., Detroit, Mich.

IDEAL plate supply operated from storage batteries. High speed ball bearing dynamotors and generators designed for Navy. May be operated by external motor or engine when ordered with shaft extension \$3.00 additional. General Electric 24/1500 volt 350 watt \$37.50. 24/750 volt 150 watt \$27.50. 12/350 volt 50 watt \$18. Crocker-Wheeler 24/1500 volt 450 watt \$45.00. Holtzer-Cabot 12/500 volt 35 watts \$20. Westinghouse 27.5/350 volt \$15. Two machines for 700 volts \$28. 0-15 volt 500 watt \$15. 10/350 volt \$18.00. 900 cycle 200 watts with exciters \$22.50. ½ KW 500 cycles \$15. Suitable transformers. List with fotos. Henry Kienzle, 501 East 84th Street, New York.

SPECIAL summer prices on crystals. 3500 Kc band \$14.00, 1700 Kc band \$9.00. Blanks \$4.00. W9DRD, Herbert Hollister, Edwardsville, Kansas.

KILOCYCLES-METERS chart, large size, given with yearly subscription to Radio Amateur Call Book, \$3.25 for 4 issues, June number just out. W9FO-508 S. Dearborn St., Chicago, Ill.

Q R A SECTION

50c straight with copy in following address form only:

W2FI—D. C. Akers, 181 Greenwood Ave., East Orange, N. J.

W2NG—W. M. Dailey, 19 East 69th St., New York City.

W6EH—Charles C. Messman, 17 E. Jefferson St., Phoenix, Ariz.

W8AOS—Curtis W. Adams, R. F. D. 1, Litchfield, Mich.

W8GV—Daniel I. Farren, 249 S. 1st Street, Lehighton, Penn.

W8KH—H. J. Bowman, 1260 Eastlawn Ave., Detroit, Mich.

W9AZZ—Earl N. Schnorr, 532 W. 8th St., Davenport, Iowa.

WIMK

A.R.R.L. Headquarters

R. B. Parmenter, Chief Op. "rp."

The following calls and personal sines belong to members of the A.R.R.L. Headquarters gang:

W1AL H. P. Westman "ws."

W1BDI-WIXL F. E. Handy "fh."

W1EH K. B. Warner "kb."

W1BUD A. L. Budlong "bud."

W1CEI J. J. Lamb "jm."

W1ES A. A. Hebert "ah."

W1KP F. C. Beekley "beek."

W1PX C. G. Kenefick "ck."

W1SZ-WIBIZ C. C. Rodimon "rod."

W2JR G. D. Meserve "dm."

W9BR B. Dudley "bd."

W9DOA L. R. Huber "ou."

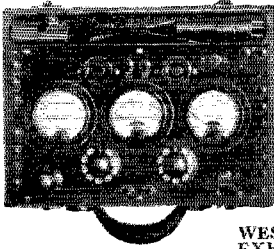

WESTON
EXHIBIT
AT HOTEL
STEVENS

The New Radio Set Tester

See it at the R. M. A. Convention

THE radio industry is familiar with the Weston Model 537 Radio Set Tester — for A.C. and D.C. receivers. Service men hailed it with great acclaim a year ago, noting its many advantages over the Weston Model 519 — for D.C. only.

And NOW — here is another great advance — the Weston Model 547 — incorporating many additional features to meet the service testing requirements of radio's latest developments. And there have been many since the last R. M. A. Convention. But with this NEW SET TESTER radio servicing is still further simplified, even taking into account the number of new tubes, sets and circuits. Space won't permit description here — nor would words alone do this new set tester justice. You must see it for yourself — operate it — try to think up some service problem it can't solve. Try as you will the Model 547 will give you a quick and accurate answer every time. Convenient — complete — light and rugged. Handsome in appearance — and it will yield you handsome profits. It will increase your business and your prestige. **YOU CAN BANK ON IT!**

This instrument has many outstanding service features. But first of all it is a Weston — assuring you exquisite workmanship and complete service reliability. It is provided with three instruments — all 3¼" diameter and furnished with bakelite cases. Carrying case, removable cover, panel and fittings are also made of sturdy bakelite.

WESTON ELECTRICAL
INSTRUMENT CORPORATION

602 Frelinghuysen Ave., Newark, N. J.

Weston
PIONEERS
SINCE 1888
INSTRUMENTS

For Your Convenience

QST'S

INDEX OF ADVERTISERS IN THIS ISSUE

Actee Wire Company.....	90
Aero Products, Inc.....	82, <i>3rd cover</i>
Aerovox Wireless Corp.....	82
Allen-Bradley Company.....	72
American Sales Co.....	84
Ambion Corporation of America.....	84
Arcturus Radio Company.....	89
Auriema, Inc., Ad.....	82
A.R.E.L. Application Blank.....	91
A.R.H.L. Handbook.....	91, <i>2nd cover</i>
Barawik Company.....	79, 89
Barros & Cia., M.....	90
Burgess Battery Company.....	4th cover
Candler System Co.....	85
Cardwell Mfg. Corp., Allen D.....	73
Central Radio Labs.....	91
Chicago Radio Apparatus Co.....	79
Claroostat Mfg. Company.....	84
Corning Glass Works.....	79
Crosley Radio Corp.....	96
Cunningham, Inc., E. T.....	87
Dodge, C. K.....	80
Donagan Elec. Mfg. Co.....	74
Eastern Radio Institute.....	91
Electrad, Inc.....	85
Electric Specialty Co.....	79
Frost, Inc., Herbert H.....	81
General Radio Company.....	8
Groben, F.....	91
Gulf Radio School.....	83
Hardwick, Hindle, Inc.....	88
Jewell Electrical Inst. Corp.....	6
Kruse, Robert S.....	83
Leeds Radio Company.....	77
Loomis Publishing Co.....	80
Manhattan Elec. Bargain House.....	83
McGraw-Hill Book Co.....	76
National Company.....	87
National Radio Tube Co.....	90
Pacent Elec. Company.....	89
Patten, E. E.....	85
Pilot Elec. Mfg. Co.....	75
Potter Company, The.....	83
QST Binders.....	89
Radio Amateur Call Book.....	85
Radio Engineering Labs.....	74
Radio Parts Sales Co.....	81
Radio-Victor Corp. of America.....	41
Ramsey Publishing Co.....	87
Raytheon Mfg. Co.....	79
Rectifier Engineering Service.....	83
Rooney, John T.....	87
Rossiter & Company.....	86
Sangamo Electric Co.....	<i>Insert</i>
Scientific Radio Service.....	85
Silver-Marshall, Inc.....	4, 5
Teleplex Company.....	88
Thordarson Elec. Mfg. Co.....	96
Transcontinental Coils.....	89
Van Nostrand Company, D.....	71
Vibroplex Company.....	86
Ward-Leonard Electric Co.....	81
Weston Electrical Instrument Corp.....	94
West Side Y. M. C. A.....	87
X-L Radio Labs.....	81
Vaxley Mfg. Company.....	88

AMATEUR DEPARTMENT.

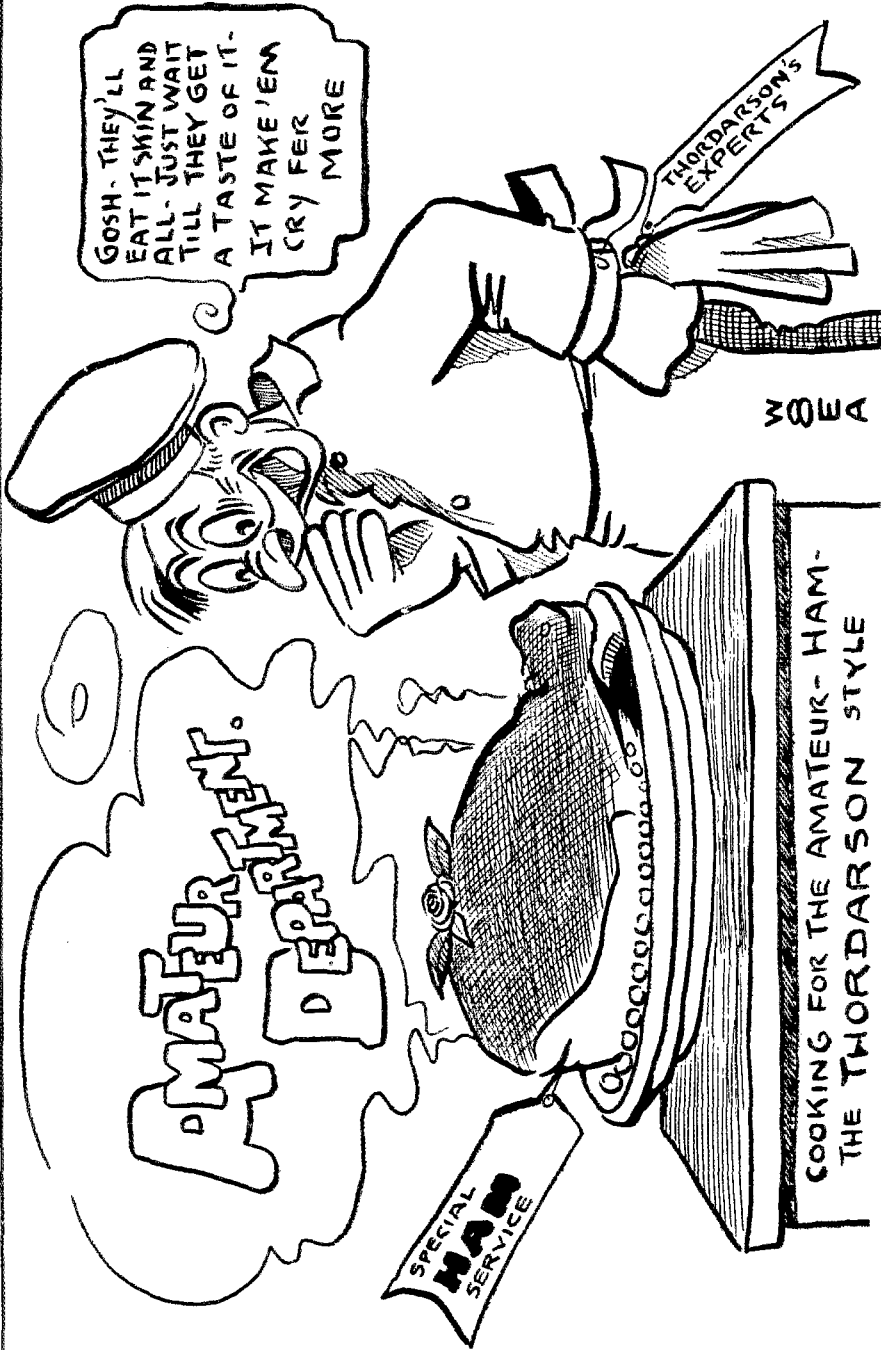

GOSH - THEY'LL
EAT IT SKIN AND
ALL - JUST WAIT
TILL THEY GET
A TASTE OF IT -
IT MAKE 'EM
CRY FER
MORE

THORDARSON'S
EXPERTS

WSEA

COOKING FOR THE AMATEUR - HAM -
THE THORDARSON STYLE

P.S. SEND FOR NEW HAM BULLETIN
TELLS ALL ABOUT IT.

THORDARSON ELECTRIC MFG. CO.

HURON, KINGSBURY 8 LARRABEE STS.

CHICAGO.

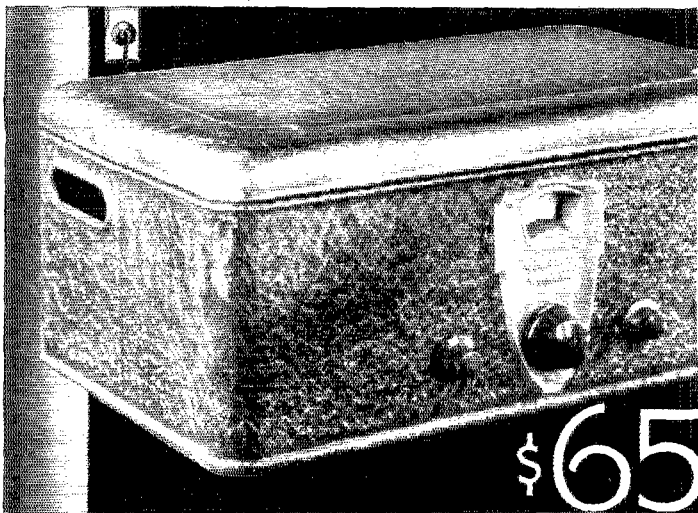

GEMBOX

The GEMBOX has three stages of radio frequency amplification, detector, 2 audio with 47-L-A power tube in last stage and a rectifying tube — 7 tubes in all. Shielded — illuminated dial — power output tube — Mersbon condenser in power supply — AC electric operation. All modern, up-to-minute quickscale features.

Installed with the Dynacone in the . . .

GEMCHEST

You have the smartest radio set on the market, and at a price that makes quick sales. The GEMCHEST design is adapted from the Chinese Chipendale — three exquisite color combinations — Mandarin red with bronze gold hinges and fittings — Nanking green with rose gold — Manchu black with white gold. Stylish — new — individual — perfectly fitting into modern home interiors.

The SHOWCHEST is the same but is equipped with the 8-tube SHOWBOX receiver selling at \$109.

Both the GEMCHEST and SHOWCHEST come equipped with the improved Dynacone.

The Crosley JEWELBOX selling at \$105 is another wonderful value.

THE CROSLEY RADIO CORPORATION

Dept. 18 Cincinnati, Ohio

Paul Crosley, Jr., President

Owners of WLW — the nation's station

Montana, Wyoming, Colorado, New Mexico and West prices slightly higher

Prices quoted do not include tubes

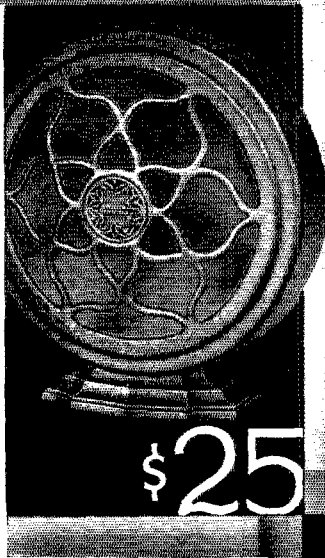

IMPROVED
DYNAONE

THE SMART GEMCHEST



NEW GEMBOX AC ELECTRIC 7 TUBE

THE DYNAONE is a different type of power speaker that takes its field current from the set which operates it. This employment of the armature principle of actuation has improved reproduction to a marked degree. Each tone is true in its relation to every other tone of the audible scale.

THE WORLD'S
THREE GREAT
RADIO VALUES

CROSLEY RADIO

\$94

AERO COIL

Wave-Meter

New!

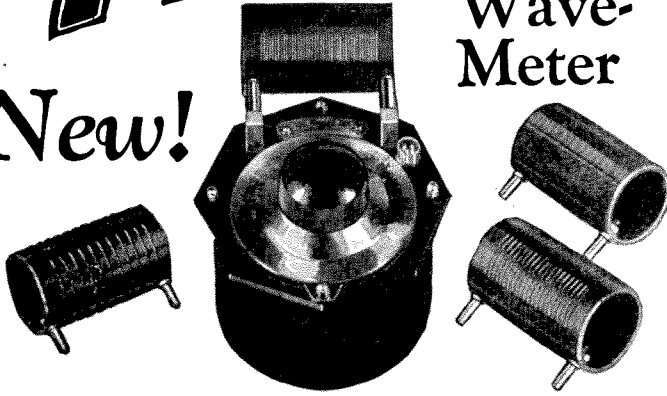

100 Divisions — Readable to 1-10th of a Division

The Aero Wavemeter was designed for the radio amateur and the experimenter. It is of rugged mechanical and good electrical construction and meets the exacting requirements of the properly conducted amateur station.

Using the principle of the "series gap," and having a definite fixed minimum capacity, the amateur wavelength bands are spread over a great many dial divisions. The velvet vernier dial has 100 divisions, each of which may be read to one-tenth of a division.

The 5-meter band covers 40 dial divisions; the 10-meter, 40 divisions; 20-meter, 17 divisions and the 40-meter band, 25 divisions. For the 80-meter band, two coils are used.

One (72 to 82 meters) covers 45 divisions, and the other (80 to 90 meters) covers 65 divisions.

Each coil excepting the 5-meter, uses No. 18 enameled wire tightly wound into grooves of the bakelite tubing. The tubing has a 1/4 in. wall and is 2 in. in diameter. The Aero heavy duty plugs and jacks make positive contact. The heavy brass case has a black crackle finish. The 3/16" black bakelite top is hexagonal shape to prevent rolling. The indicator is a standard neon lamp. Each wavemeter is individually hand calibrated. Standard coils shown are 20, 40 and 80 meters, included in price. 5- and 10-meter coils extra. Furnished with or without neon lamp indicator.

Write for prices and special circular

Aero High-Power Xmitter and 150-Watt Amplifier

For operation on 10-20-40-80-100M. Bands

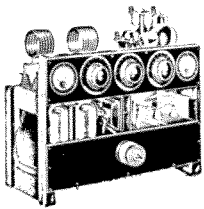

The first high-power amplifier to use the UX-860 screen grid tubes. 1929 In Every Detail. 150 Watts of Pure D.C. Signals with a Stability Which Has Caused Favorable Remarks Everywhere. Flexibility that Fits Every Ham Need.

You can use either two UX-852 tubes when using this new Aero Kit No. 52 as a single unit for a transmitter; or two UX-860 (screen

grid) tubes, employed when using with Aero Kit No. 53; or as a 150-watt amplifier in any master oscillator combination. For those desiring a master oscillator system, this unit works with a high degree of efficiency as an amplifier. With two screen grid UX-860 power tubes in this arrangement, it requires no neutralizing. Hook this unit on your present oscillator, converting it into a 1929 job, with ample power for ham use. Power supply delivers 2000 volts at 250 M.A. Employs two of the R.C.A.'s newest rectifiers, UX-866. Due to the construction of the UX-866, unusually high voltage may be applied safely to them.

Kit No. 52 — Including the power supply, but not including tubes. List Price. \$259.00
Kit No. 53 — Less power supply and tubes. List Price. \$114.00

Aero Listening Monitor

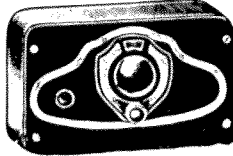

The Aero Listening Monitor enables any amateur transmitter to check his own note, to know whether it is

pure D.C. or not. It is a safe, sure and accurate way of knowing your station without depending upon the reports of others. Watching the ammeter won't help you — you need the Aero Monitor to be absolutely positive.

The Aero Monitor is a completely shielded unit encased in a black metal cabinet, size 9 x 5 1/4 x 2 1/4 in. Filament and B supply is included. It operates with a UX-199 type of tube and employs a stable circuit, delivering a signal intensity of about R-4 or 5. Equipped with automatic filament control. The battery supply is thoroughly shielded from the R.F. A reliable, scientific instrument. Ship. wt., about 2 1/2 lbs.

Model M-29 Aero Monitor, including Dry Batteries, but no tube. List Price. . \$15.00

Send for Aero Green Book and 1929 Supplement showing newest Short Wave Products. Price. 25c

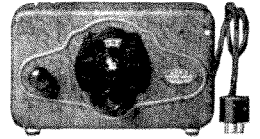

"Aero-Call" Factory-Built Short-Wave Converter

No short-wave converter on the market is comparable with the new 1929 "Aero-Call." Its advent sounds a new era in short-wave converts. Many factory-built items of this character now being sold are giving trouble particularly on the A.C. models, because there has been found no general adaptation of converters to the A.C. filter on the broadcast sets. The new "Aero-Call" Converters eliminate all these difficulties.

Model A for A.C. Sets \$25.00
Model D for D.C. Sets \$25.00

New 1929 Receiving Coils

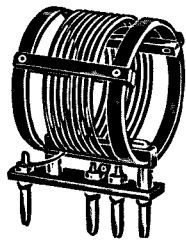

Designed for the new amateur 20, 40 and 80 meter bands, for use with .00003 condenser, including plug-in base with new design adjustable space wound primary. Complete

Kit L. W. T. 13, 3 coils, \$12.50.
Single coils — 8.2 to 12.6 meters; 19.4 to 21.5 meters; 40.0 to 45.0 meters; 75.0 to 80.0 meters, \$4.00 each. L. W. T. 100-P, Plug-in base, \$3.00. .00003 Condenser, \$1.50. This condenser to be shunted with a .00008 Fixed Condenser.

New 1929 Transmitting Coils

In accord with 1929 practice. First use of plug-in coils for high power up to 75 amperes. Heavy aluminum carries 500 watts safely. New material space bar superior to glass. Many new features. For use with 450 m.m.f.

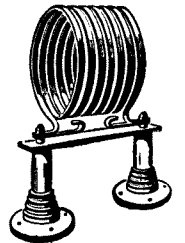

condenser. Kit of 2 coils with plug-in mounts, 9.6 to 27.0 meters \$15.00; 14.2 to 43; also 31.8 to 90.3 meters, \$15.00. Single coils, \$5.50, without bases. Plug-in mountings only, pair \$3.50. Plugs only, with nuts, pair \$2.00.



New 1929 Aero Grid Choke No. C-250
A Compact Choke Coil for suppressing high frequency oscillations in transmitting vacuum tubes. Price \$1.50.

Aero Transmitting Choke No. C-248, \$1.50.

Aero Transmitting Choke No. C-249

\$1.50, C-60, \$1.50, C-65, \$1.50

Send for new Short-wave supplement showing new 1929 products. It is free to QST readers

4611 E. Ravenswood Ave., Dept. 369 **AERO PRODUCTS** Chicago, Illinois, U. S. A. INCORPORATED

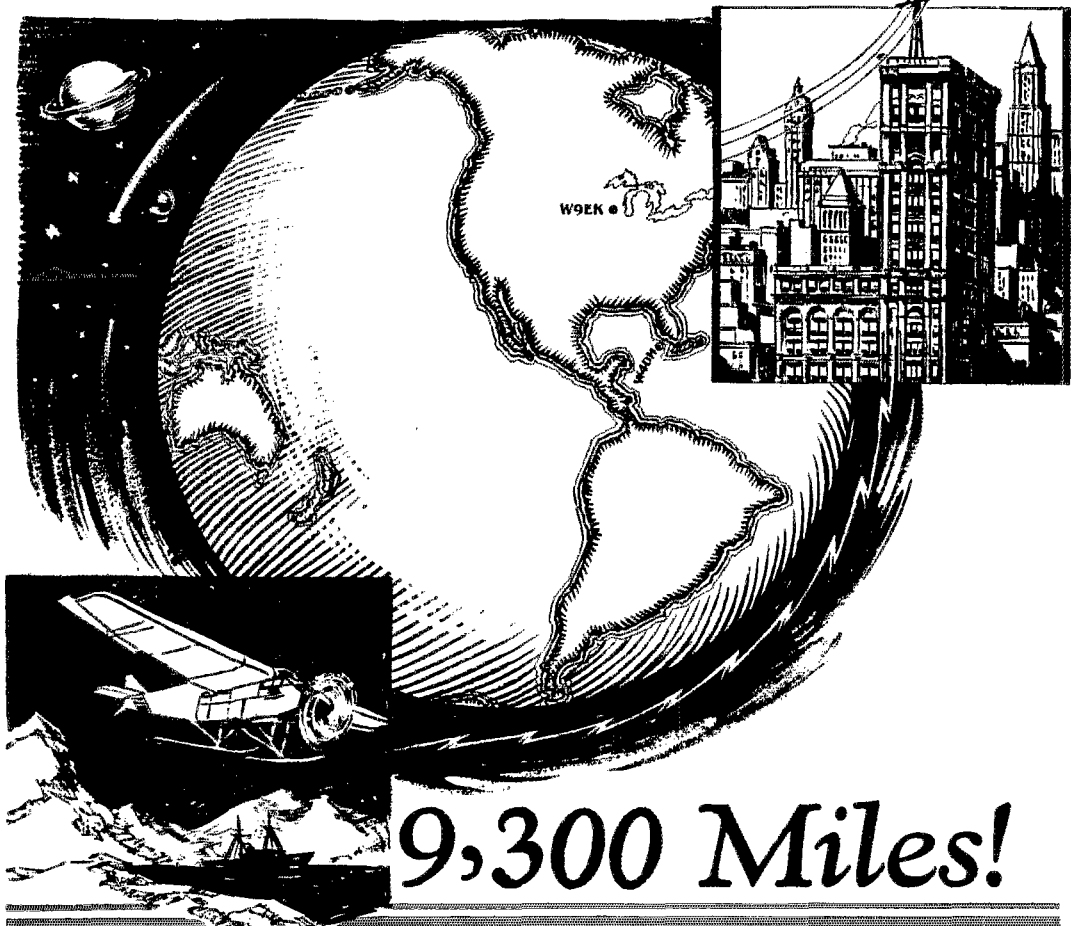

9,300 Miles!

The World's Record! Direct two way radio communication between the New York Times Radio Station and Commander Byrd's Airplane flying over the Antarctic.

Every Radio Amateur should know that Burgess Radio Batteries are used in the Antarctic Expedition radio stations.

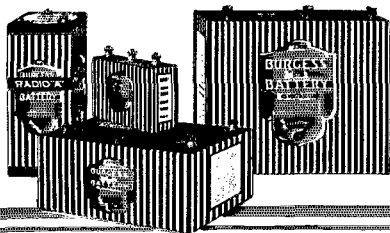

Ask Any Radio Engineer

BURGESS BATTERY COMPANY

MADISON,

WISCONSIN

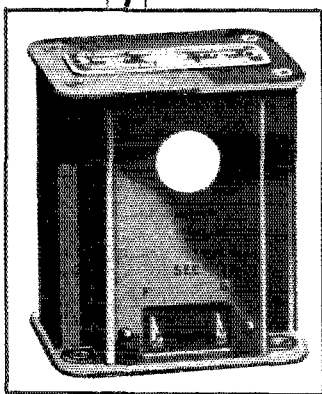
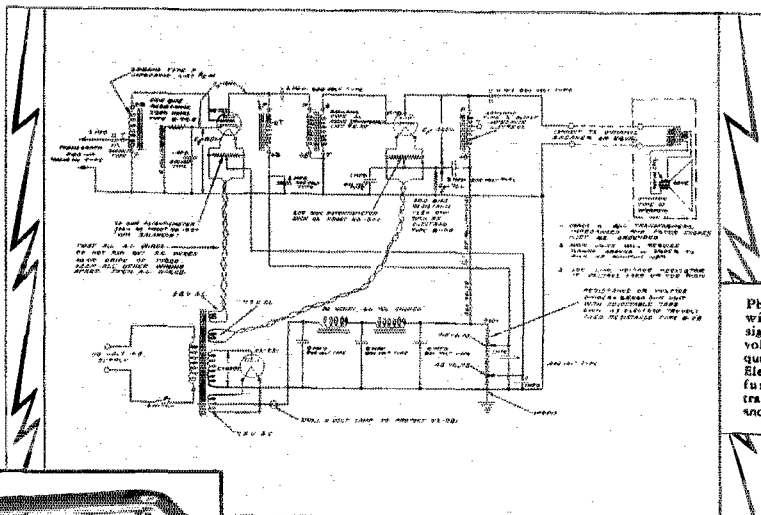

TONE- sells the phonograph amplifier, too!

The exacting standards to which phonograph amplifiers must measure require manufacturers to exercise increasing care in the design of circuits and the selection of parts of *known accuracy in performance*.

Sangamo Audio Transformers are built to precision standards with electrical characteristics that will give unsurpassed reproduction when used in appropriate circuits.

The proof of transformer excellence lies in a flat performance curve. Due to

the fact that the impedance of the windings of all Sangamo Audio Transformers is accurately matched to the impedances of the tubes and speakers with which they work, the Sangamo performance curve is the nearest to a straight line ever achieved by any transformers now available.

When equipped with a good phonograph pick-up and a speaker that will handle the volume output, this amplifier and power supply will give an exceptionally high quality of tone and large volume.

SANGAMO ELECTRIC CO.

SPRINGFIELD, ILLINOIS, U. S. A.

Sangamo Electric Co. of Canada, Ltd., 183 George St., Toronto, Ont.

For 30 years preeminent manufacturers of electrical precision instruments

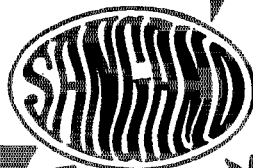

The quality of fixed condensers affects every note and syllable

Sangamo Fixed Condensers are accurate and stay accurate!

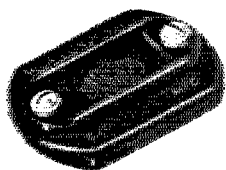

Standard Type "A"
Sangamo Fixed Condenser

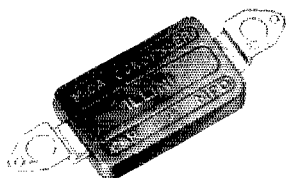

The New "Illini" Condenser
For Manufacturer's Use

COSTLY experience has brought home to many manufacturers the realization that no other item costing so little can cause as much trouble as a fixed condenser.

Not all fixed condensers are good condensers even though molded in Bakelite. Sangamo Fixed Condensers are not only rendered immune to thermal changes and mechanical damage by a Bakelite enclosure—but a soundly constructed, *accurately rated* mica condenser within the Bakelite casting assures minimum variations from rated capacities.

Sangamo precision manufacturing traditions and facilities, including one of the country's finest equipped laboratories, are responsible for Sangamo accuracy. Every Sangamo product is subjected to searching tests of the sort possible to make only in a manufacturer's laboratory. The standard line of Sangamo Fixed Condensers is tested within ten per cent of rated capacity.

The Sangamo "Illini" Condenser for manufacturer's use, is a new type of the same quality as the standard Sangamo Fixed Condenser. Its connecting lugs, which may be bent to any position required without damaging the condenser, adapt it more readily to factory production.

Mail the coupon for complete information and prices.

Pin this to your letterhead and mail

SANGAMO ELECTRIC CO., Springfield, Illinois, U. S. A.
Dept. 54

Sangamo Electric Co. of Canada, Ltd., 183 George St., Toronto
(For manufacturers) I am interested in engineering data regarding your transformers and condensers, especially the phonograph amplifier hook-up.

(For dealers) Please send data on Sangamo Condensers.

(For set builders) Please send booklet describing your apparatus and latest audio hook-ups. I enclose \$1.00 to cover cost of mailing.